

DETAILS OF SURFACING AT INTERSECTIONS AND SIDEROADS

| | | | | |
|----------------------|---------------|--------------------|--------------|-----------|
| F.A.S. | SECTION | COUNTY | TOTAL SHEETS | SHEET NO. |
| 815 | 02-0075-01-BS | WHITE | 8 | 3 |
| RD. ROAD DIST. NO. 1 | ILLINOIS | BURNT PRAIRIE ROAD | | |
| LEC JOB # H121001WH | | CONTRACT # 59478 | | |

DETAIL OF INTERSECTION RT. AND LT. STA. 167+74

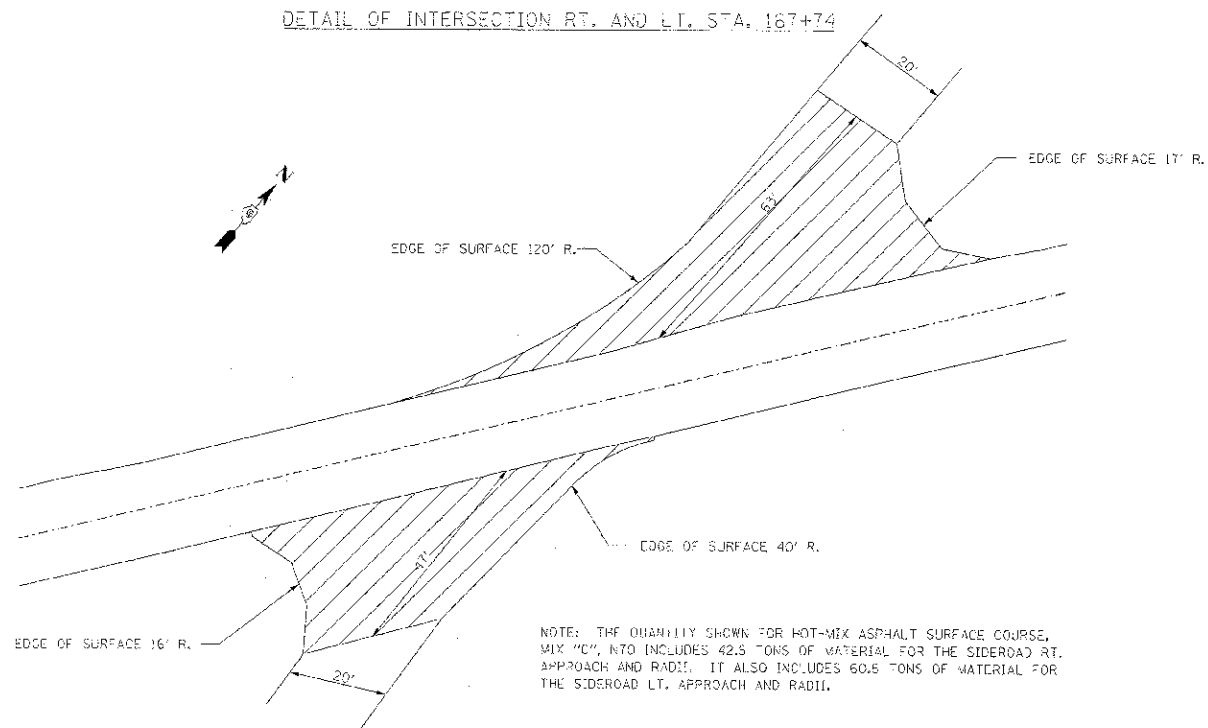

NOTE: THE QUANTITY SHOWN FOR HOT-MIX ASPHALT SURFACE COURSE, MIX "C", N70 INCLUDES 42.5 TONS OF MATERIAL FOR THE SIDEROAD RT. APPROACH AND RADIUS. IT ALSO INCLUDES 60.5 TONS OF MATERIAL FOR THE SIDEROAD LT. APPROACH AND RADIUS.

PROFILE LT

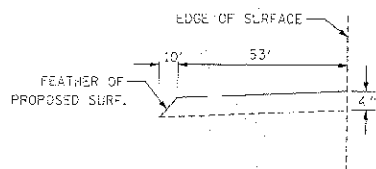

PROFILE RT

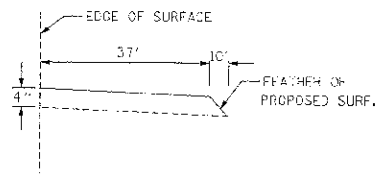

DETAIL OF INTERSECTION LT. STA. 223+50

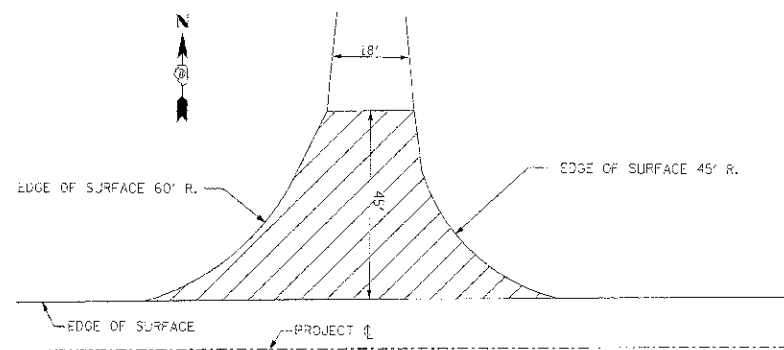

NOTE: THE QUANTITY SHOWN FOR HOT-MIX ASPHALT SURFACE COURSE, MIX "C", N70 INCLUDES 56.6 TONS OF MATERIAL FOR THE SIDEROAD APPROACH AND RADIUS.

PROFILE LT

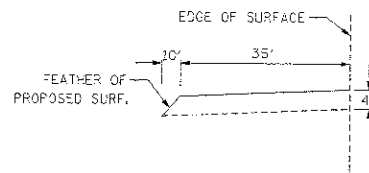

DETAIL OF INTERSECTION RT. AND LT. STA. 250+94

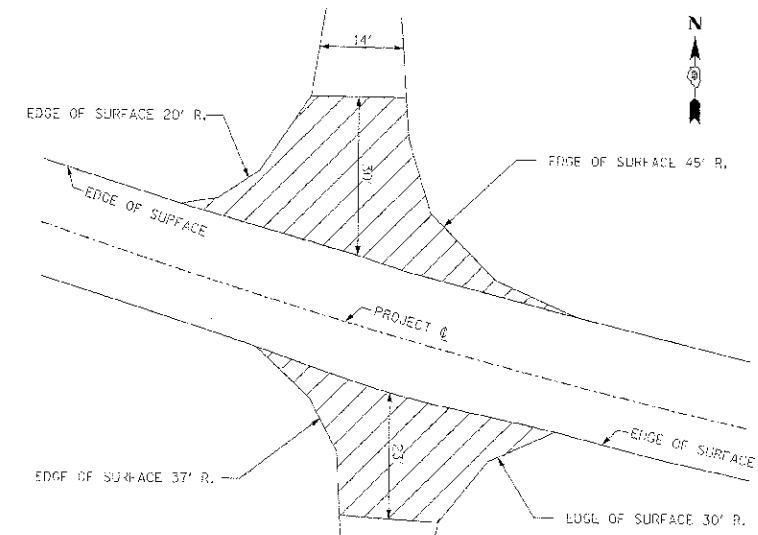

NOTE: THE QUANTITY SHOWN FOR HOT-MIX ASPHALT SURFACE COURSE, MIX "C", N70 INCLUDES 20.2 TONS OF MATERIAL FOR THE SIDEROAD RT. APPROACH AND RADIUS. IT ALSO INCLUDES 26.6 TONS OF MATERIAL FOR THE SIDEROAD LT. APPROACH AND RADIUS.

PROFILE LT

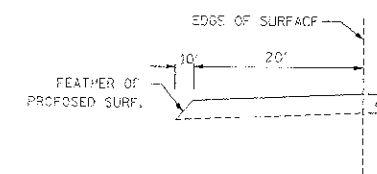

PROFILE RT

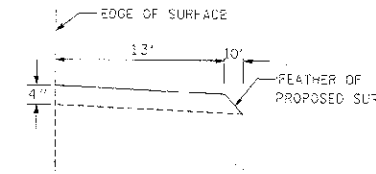

DETAIL OF INTERSECTION RT. AND LT. STA. 253+90

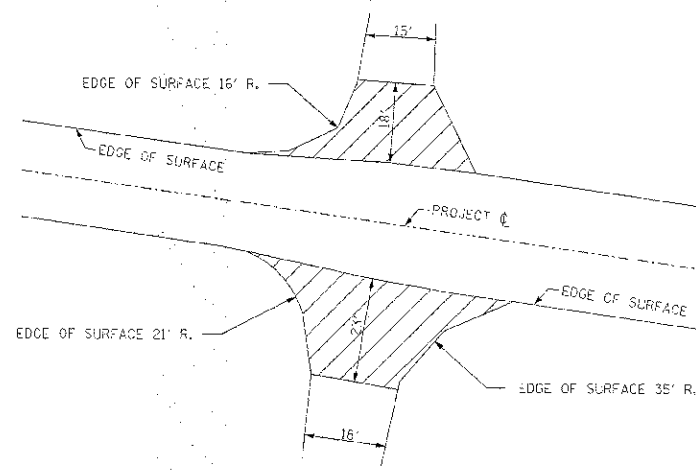

NOTE: THE QUANTITY SHOWN FOR HOT-MIX ASPHALT SURFACE COURSE, MIX "C", N70 INCLUDES 20.9 TONS OF MATERIAL FOR THE SIDEROAD RT. APPROACH AND RADIUS. IT ALSO INCLUDES 13.5 TONS OF MATERIAL FOR THE SIDEROAD LT. APPROACH AND RADIUS.

PROFILE LT

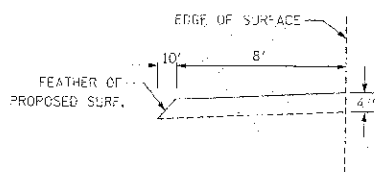

PROFILE RT

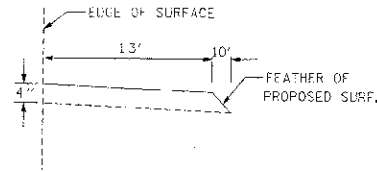

DETAIL OF INTERSECTION RT. AND LT. STA. 258+50

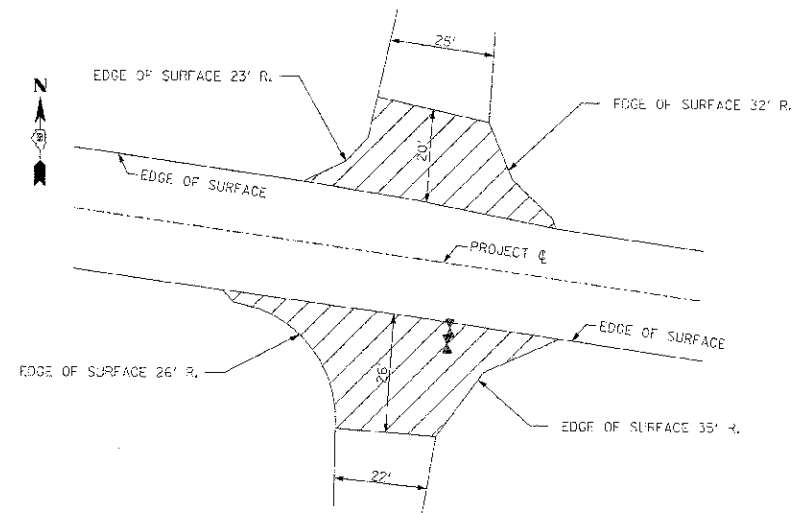

NOTE: THE QUANTITY SHOWN FOR HOT-MIX ASPHALT SURFACE COURSE, MIX "C", N70 INCLUDES 28.3 TONS OF MATERIAL FOR THE SIDEROAD RT. APPROACH AND RADIUS. IT ALSO INCLUDES 20.7 TONS OF MATERIAL FOR THE SIDEROAD LT. APPROACH AND RADIUS.

PROFILE LT

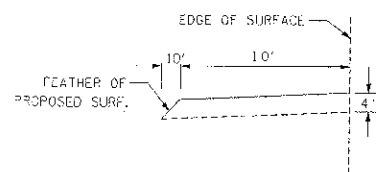

PROFILE RT

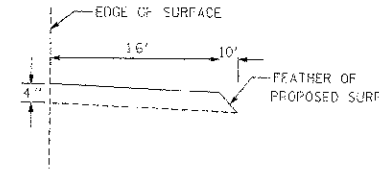

DETAIL OF INTERSECTION RT. AND LT. STA. 264+50

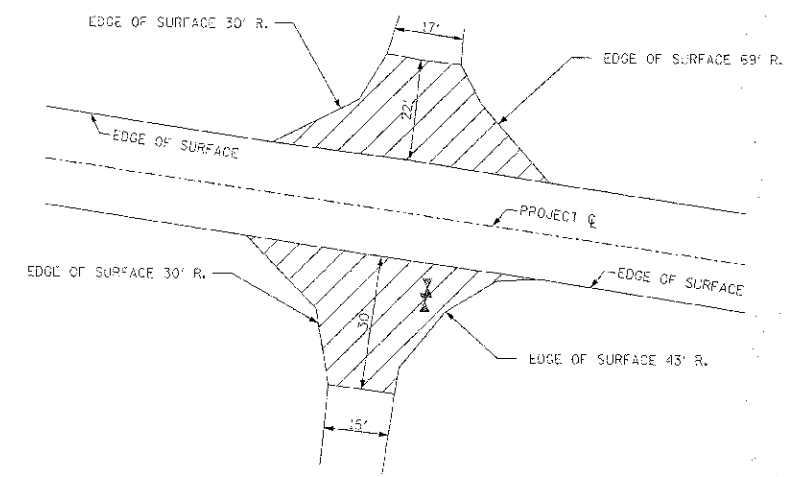

NOTE: THE QUANTITY SHOWN FOR HOT-MIX ASPHALT SURFACE COURSE, MIX "C", N70 INCLUDES 24.5 TONS OF MATERIAL FOR THE SIDEROAD RT. APPROACH AND RADIUS. IT ALSO INCLUDES 22.0 TONS OF MATERIAL FOR THE SIDEROAD LT. APPROACH AND RADIUS.

PROFILE LT

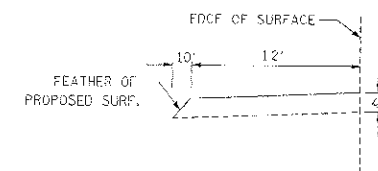

PROFILE RT

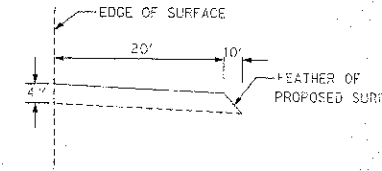

323 W. 3RD ST.
P.O. BOX 160
MT. CARMEL, IL
62863
PHONE:
(618)-282-8651
FAX:
(618)-283-3327

405 W. STATE ST.
SUITE 1
PRINCETON, IN
47570
PHONE:
(812)-386-7811
FAX:
(812)-383-2812



PROFESSIONAL DESIGN FIRM
LAND SURVEY & PROFESSIONAL
ENGINEERING CORPORATION
184-03087
(62 032438) (35-022769)

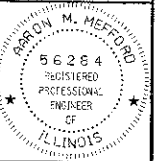

AARON M. MEFFORD
NAME
Aaron M. Mefford
SIGNATURE
5-23-12
DATE
11-30-13
EXPIRES