

EXISTING TYPICAL SECTION FOR RAMPS

LEGEND

- ① EXISTING CRC PAVEMENT, ± 9"
- ①A EXISTING P.C.C PAVEMENT, ± 10"
- ② EXISTING STABILIZED SUB-BASE, 4"
- ③ EXISTING HOT-MIX ASPHALT SURFACE (AFTER MILLING), ± 1 1/2 "
- ③A EXISTING HOT-MIX ASPHALT SURFACE (AFTER MILLING), 1"
- ④ EXISTING HOT-MIX ASPHALT SHOULDER
- ⑤ EXISTING STABILIZED SHOULDER
- ⑥ EXISTING AGGREGATE SHOULDER TYPE "B"
- ⑦ PROPOSED HOT-MIX ASPHALT SURFACE REMOVAL, 1 3/4"
- ⑧ PROPOSED HOT-MIX ASPHALT SURFACE REMOVAL, 2"
- ⑨ PROPOSED POLYMERIZED HOT-MIX ASPHALT BINDER COURSE, STONE MATRIX ASPHALT, N80, 2"
- ⑩ PROPOSED POLYMERIZED HOT-MIX ASPHALT SURFACE COURSE, STONE MATRIX ASPHALT, N80, 2"
- ⑪ PROPOSED HOT-MIX ASPHALT BINDER COURSE, IL-19, N70, 2 1/4"
- ⑫ PROPOSED HOT-MIX ASPHALT SURFACE COURSE, MIX. "D", N70, 1 1/2"
- ⑬ PROPOSED SHOULDER RUMBLE STRIP
- ⑭ PROPOSED AGGREGATE WEDGE SHOULDER, TYPE "B"
- ⑮ PROPOSED GRADING AND SHAPING SHOULDER
- ⑯ PROPOSED HOT-MIX ASPHALT SURFACE REMOVAL, 2 1/4"
- ⑰ PROPOSED POLYMERIZED LEVELING BINDER, IL-4.75, N50, 3/4"
- ⑱ PROPOSED HOT-MIX ASPHALT SURFACE REMOVAL, 1 1/2 " (OUTSIDE SHOULDER UNDER THE BRIDGES)

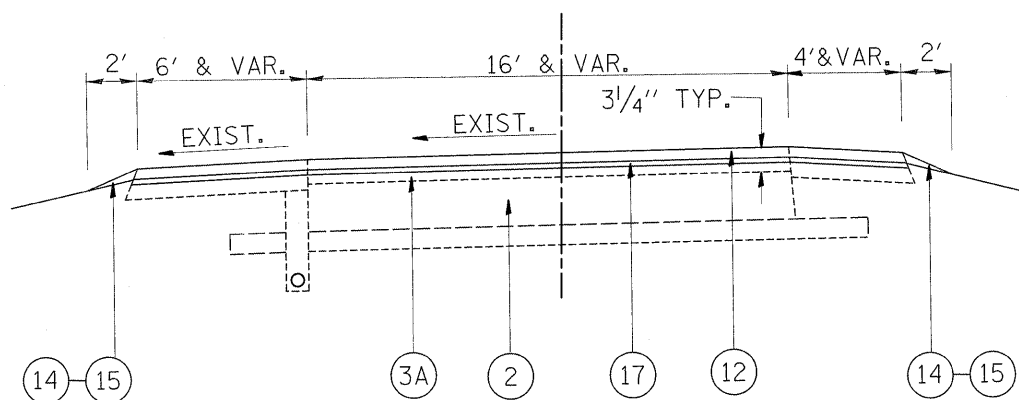

PROPOSED TYPICAL SECTION FOR RAMPS

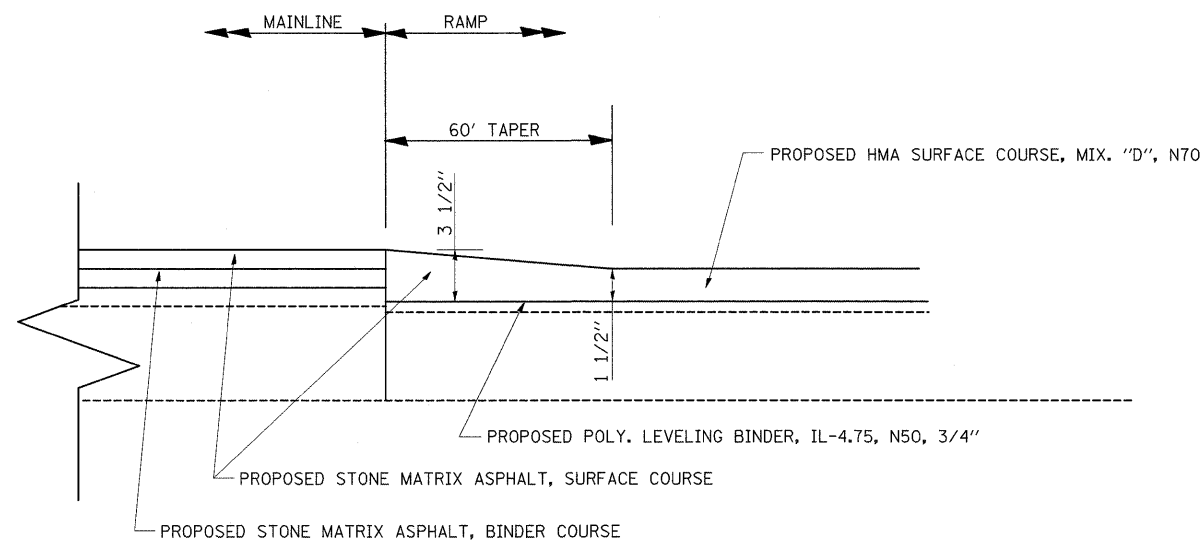

DETAIL FOR MAINLINE AND RAMP TRANSITION

NOTE:

- CONTRACTOR SHALL PATCH BEFORE MILLING
- PP-3 CONCRETE SHALL BE USED FOR CLASS A PATCHES AND ALL PATCHES SHALL BE IN PLACE NO LATER THEN 3:00 PM SATURDAY

FILE NAME =	USER NAME = abebawa	DESIGNED -	REVISED -	STATE OF ILLINOIS DEPARTMENT OF TRANSPORTATION	IL. ROUTE 57 TYPICAL SECTION FOR RAMPS		F.A.I. RTE. 57	SECTION 2009-064 RS	COUNTY COOK	TOTAL SHEETS 63	SHEET NO. 6	
c:\pwork\pwork\DOT\ABEBAWA\0142330\0175009.sht-plan.dgn		DRAWN -	REVISED -		SCALE:	SHEET NO. 1 OF 1 SHEETS	STA.	TO STA.	CONTRACT NO. 60H57			
PLOT SCALE = 50.0000 ' / IN.		CHECKED -	REVISED -		ILLINOIS FED. AID PROJECT							
PLOT DATE = 7/15/2009		DATE -	REVISED -									