

68012

F.A. RTE.	SECTION	COUNTY	TOTAL SHEETS	SHEET NO.
				48
FED. ROAD DIST. NO.		ILLINOIS FED. AID PROJECT		

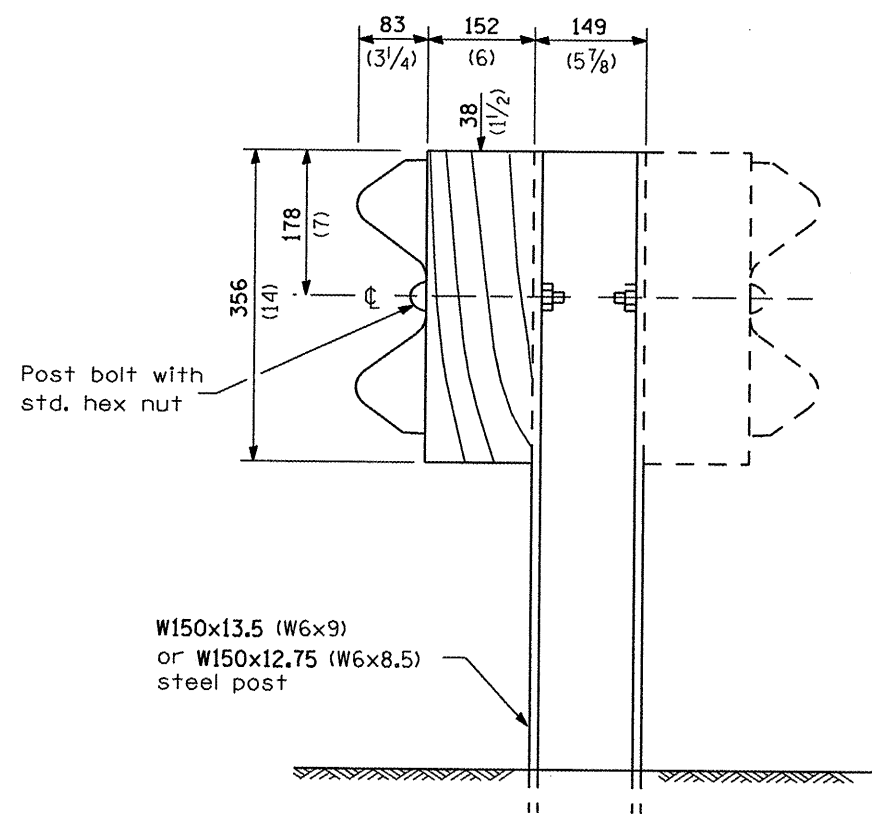

**STEEL POST CONSTRUCTION**

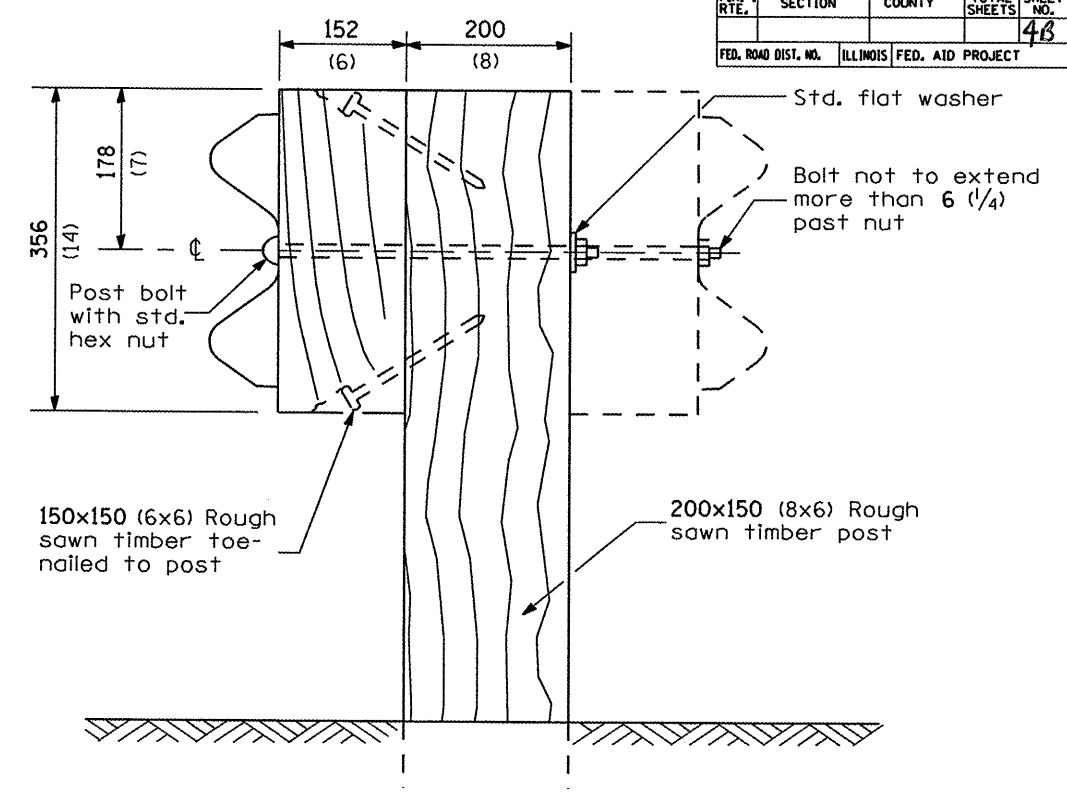

**WOOD POST CONSTRUCTION**

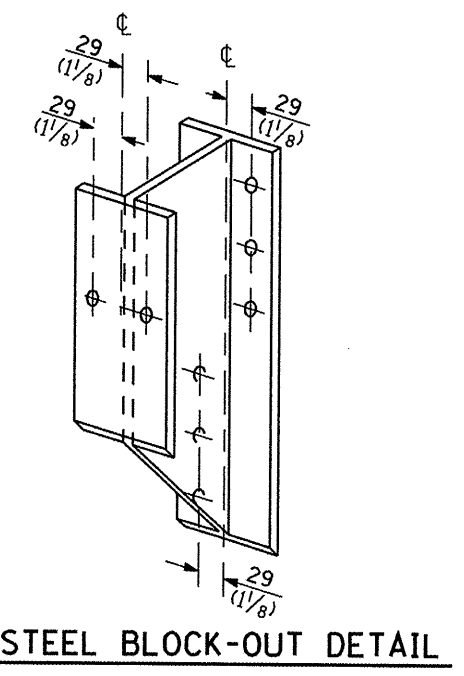

**STEEL BLOCK-OUT DETAIL**

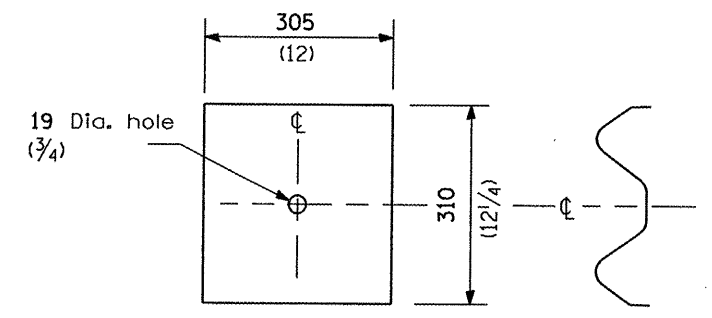

NOTE

Plate A shall be placed between rail element and block-out at non-splice mounting points only when steel block-outs are used.

**PLATE A**

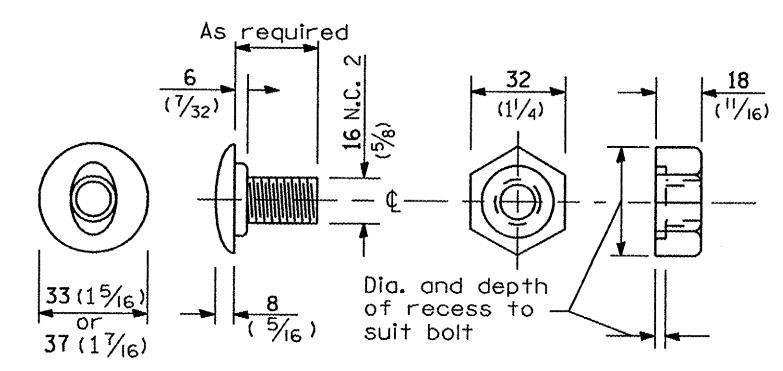

**POST OR SPLICE BOLT & NUT**

**REMOVE AND REERECT  
STEEL PLATE BEAM GUARDRAIL**  
(Sheet 2 of 4)  
**DETAIL**

48