

F.A.P. RTE.	SECTION	COUNTY	TOTAL SHEETS	SHEET NO.
502	54BR-1	ADAMS	28	6
STA.		TO STA.		
FED. ROAD DIST. NO.		ILLINOIS	FED. AID PROJECT	

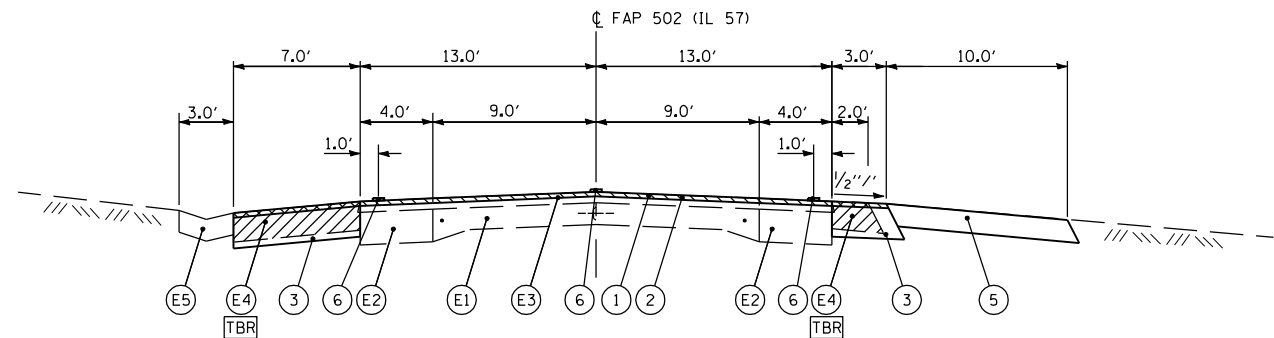

TYPICAL FAP 502 (IL 57) SECTION

STA 112+10.00 TO STA 112+34.63

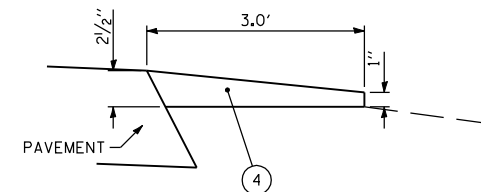

AGGREGATE SHOULDER, TYPE B (WEDGE) DETAIL

LEGEND

- (E1) EXISTING 9"-6"-6" PAVEMENT
- (E2) EXISTING HOT-MIX ASPHALT BASE COURSE WIDENING
- (E3) EXISTING HOT-MIX ASPHALT SURFACE AND BINDER COURSE, 4 3/4" AND VARIES
- (E4) EXISTING HOT-MIX ASPHALT SHOULDERS, 8"
- (E5) EXISTING CONCRETE V-GUTTER, TYPE A
- (E6) EXISTING HOT MIX ASPHALT SURFACE AND BINDER COURSE, 6" AND VARIES
- (E7) EXISTING REINFORCED PCC BASE COURSE
- (1) PROPOSED HOT-MIX ASPHALT SURFACE REMOVAL, 1 1/2"
- (2) PROPOSED POLYMERIZED HOT-MIX ASPHALT SURFACE COURSE, MIX "D", N70, 1 1/2"
- (3) PROPOSED HOT-MIX ASPHALT BASE COURSE, 10" (WIDTH > 6') OR PROPOSED HOT-MIX ASPHALT BASE COURSE WIDENING, 10" (WIDTH < 6')
- (4) PROPOSED AGGREGATE SHOULDER, TYPE B
- (5) PROPOSED AGGREGATE SHOULDER, TYPE B, 6"
- (6) PROPOSED PAINT PAVEMENT MARKING - LINE 5"

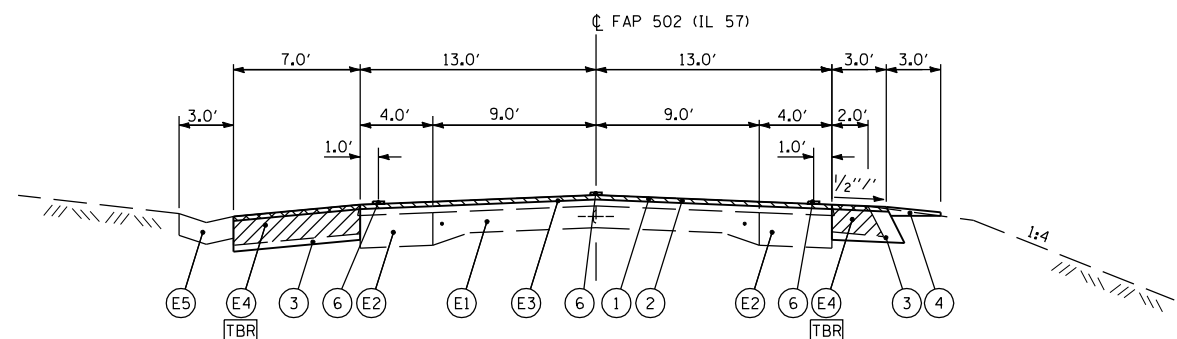

TYPICAL FAP 502 (IL 57) SECTION

STA 112+34.63 TO STA 113+32.76  
STA 116+57.00 TO STA 119+10.00

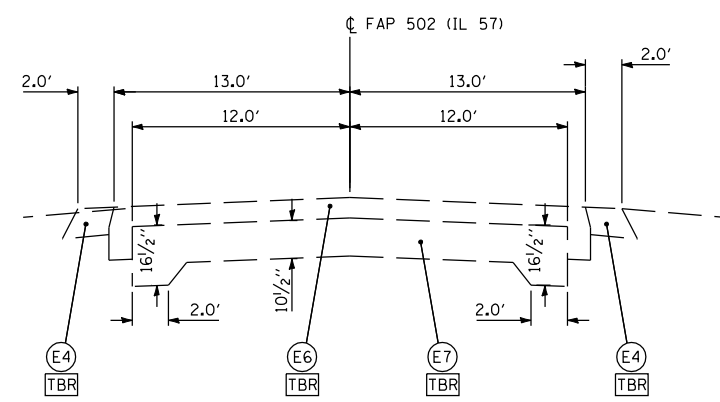

EX FAP 502 (IL 57) SECTION (APPROACH PAVEMENT)

STA 114+25 TO STA 114+53  
STA 114+96 TO STA 115+25

MIXTURE REQUIREMENTS

MIXTURE NUMBER:	1	2
LOCATIONS:	IL 57	IL 57
MIXTURE USES:	HMA SURFACE COURSE	HMA BASE CS (WIDENING)
AC/PG:	SBS PG70-22	PG64-22
DESIGN AIR VOIDS:	4.0% @ N DESIGN = 70	4.0% @ N DESIGN = 70
MIXTURE COMPOSITION (GRADATION MIXTURE):	IL 9.5 or 12.5	IL 19.0
FRICITION AGGREGATE:	MIX "D"	N/A

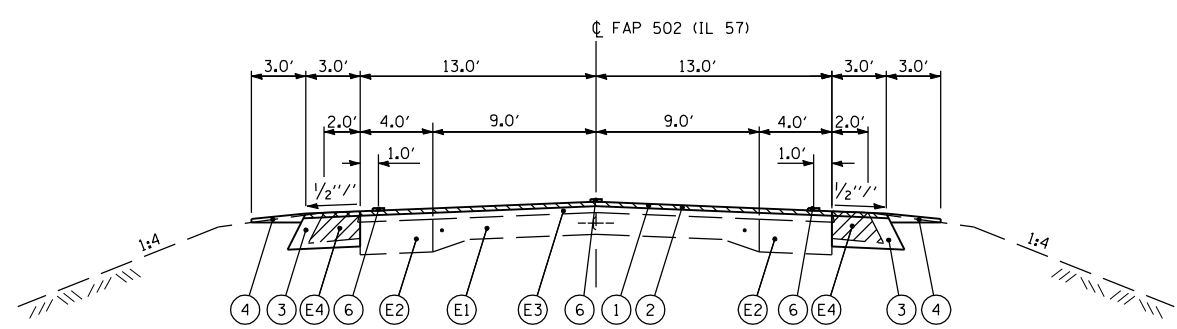

TYPICAL FAP 502 (IL 57) SECTION

STA 113+32.76 TO STA 114+17.56  
BRIDGE APPROACH PAVEMENT STA 114+17.56 TO STA 114+53.56  
BRIDGE OMISSION STA 114+53.56 TO STA 114+96.44  
BRIDGE APPROACH PAVEMENT STA 114+96.44 TO STA 115+32.44  
STA 115+32.44 TO STA 116+57.00

REVISIONS	
NAME	DATE

ILLINOIS DEPARTMENT OF TRANSPORTATION  
TYPICAL SECTIONS  
FAP 502 (IL 57)  
SECTION 54BR-1  
ADAMS COUNTY

SCALE: VERT. NONE HORIZ. NONE  
DATE: 6/28/2007  
DRAWN BY: SEB  
CHECKED BY: EBB