

BILL OF MATERIAL

Item	Unit	Total
Finger Plate	Foot	28
Expansion Joint, 5"		

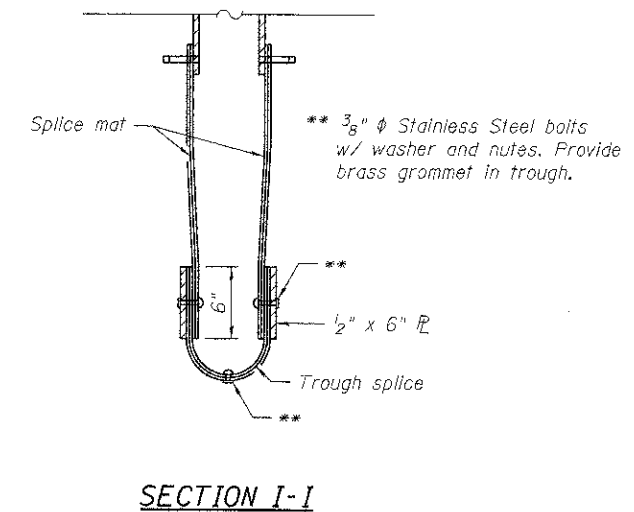
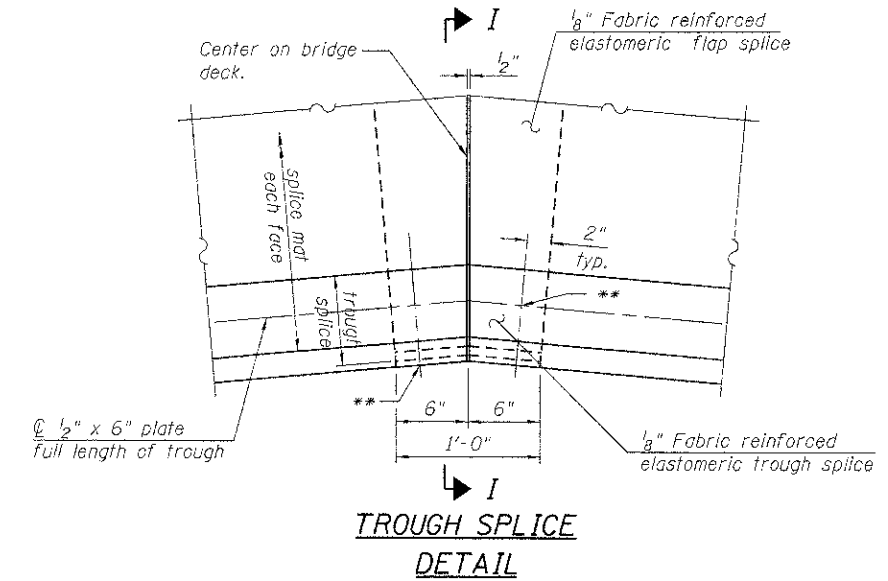

FINGER PLATE EXPANSION JOINT DETAILS
STRUCTURE NO. 056-3190

DESIGNED	SSM
CHECKED	RGD
DRAWN	WJH
CHECKED	RGD

Note:
Trough must pass over deck drainage system piping (See Sheet S-13)



HRGreen.com
Illinois Professional Design Firm
184-001322

WB CHARLES J. MILLER ROAD BRIDGE

DATE: 7/23/12

SHEET NO.	F.A.U. RTE.	SECTION	COUNTY	TOTAL SHEETS	SHEET NO.
S-20	3860	09-00372-00-PW	McHENRY	252	143
S-41	CONTRACT NO.				63633
FED. ROAD DIST. NO. 1 ILLINOIS FED. AID PROJECT					