

WING WALL ELEVATION
Showing Dimensions

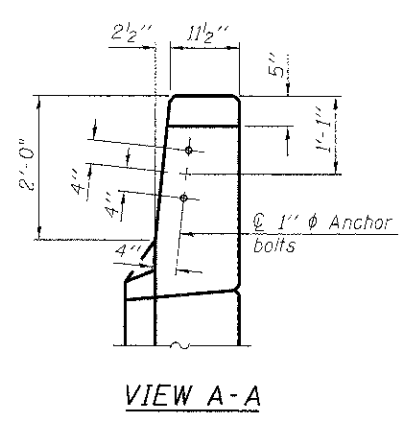

VIEW A-A

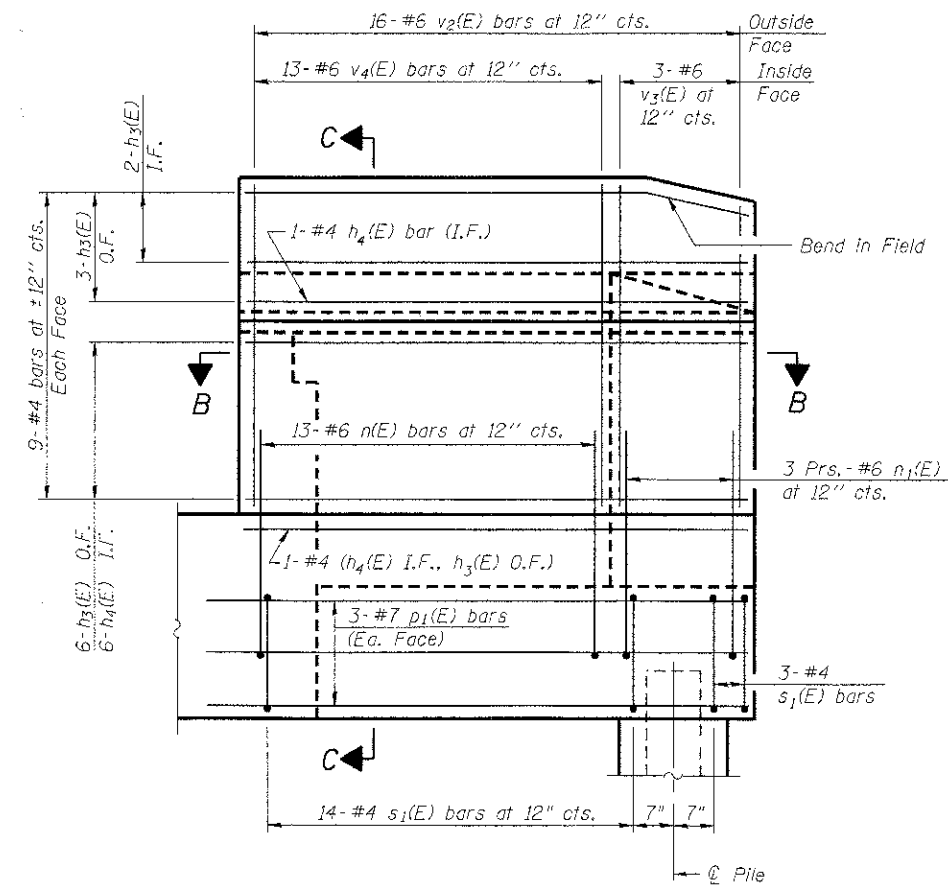

WING WALL ELEVATION
Showing Reinforcement

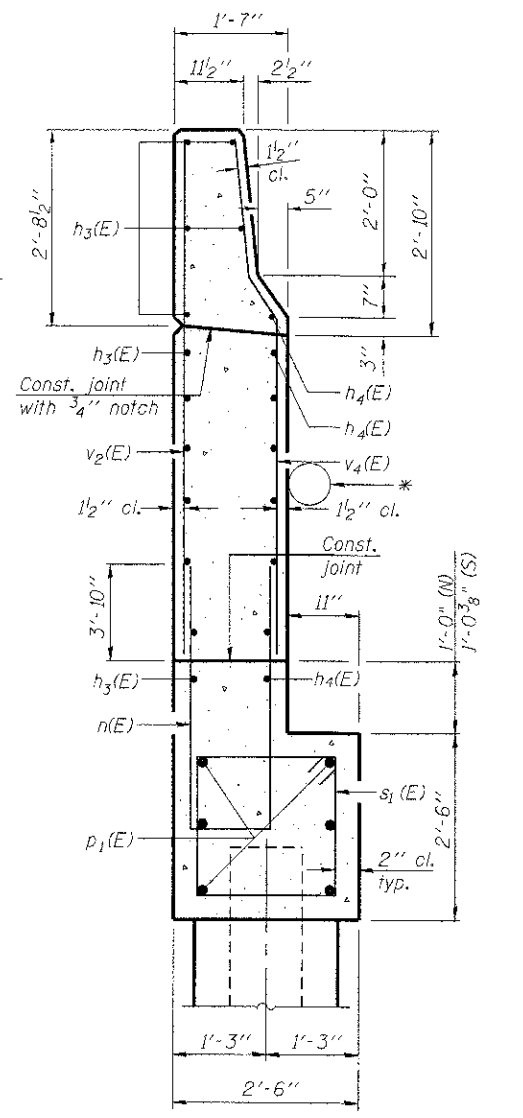

SECTION C-C

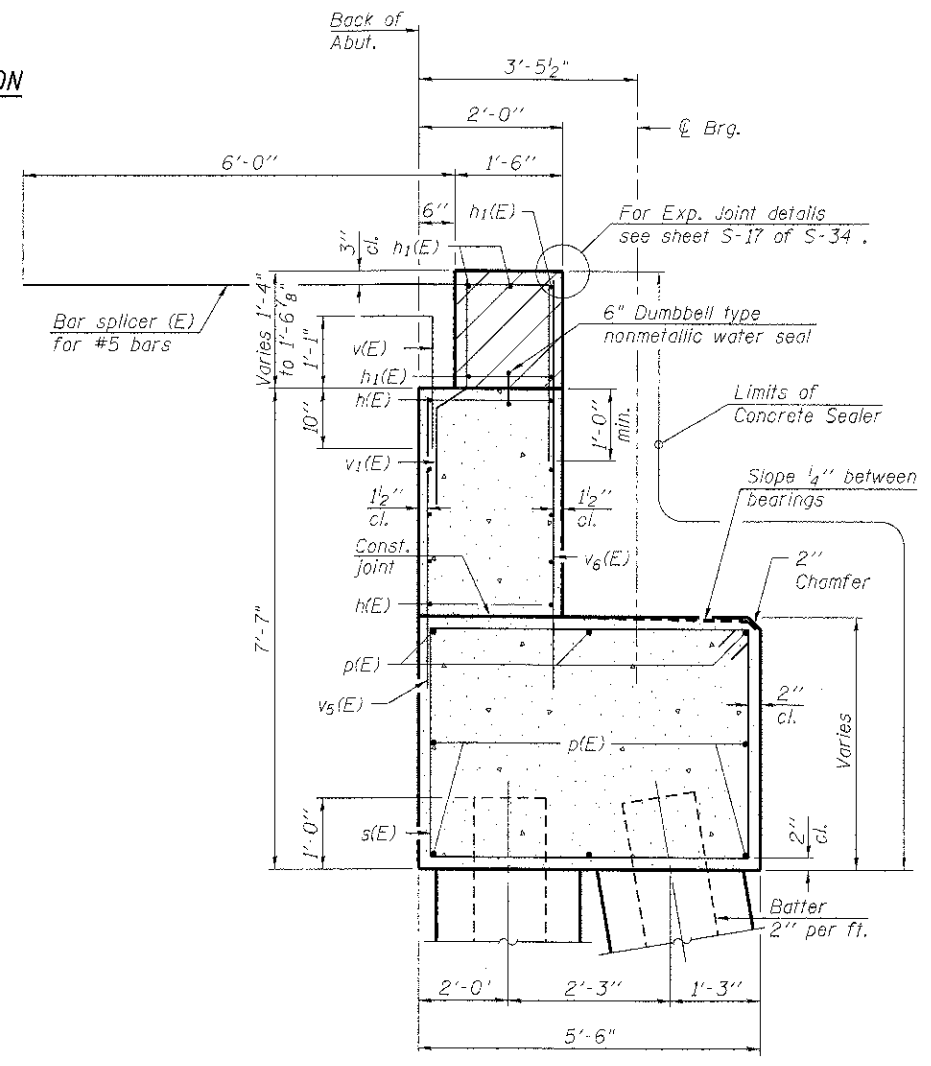

SEC. THRU ABUT.

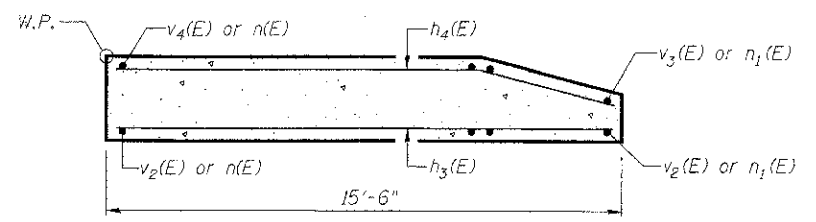

SECTION B-B

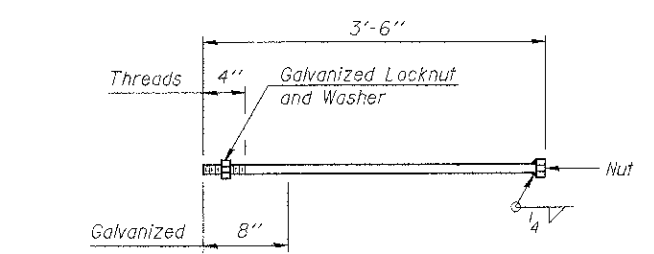

1" diameter ANCHOR BOLT

Notes:
Hatched area to be poured after superstructure false work has been removed. Quantity of concrete included with Concrete Superstructure.
Space reinforcement in cap to miss anchor bolts.
Pour steps monolithically with cap.
Quantity of concrete in end post included with Concrete Superstructure on sheet S-11 of S-41.
For Concrete Encasement details, see sheet S-35 of S-41.

* Storm Sewer, Class B, Type 2, 8" PVC.
Invert Elev. at Backwall = 747.65
See West Approach Slab Plans (S-08) for Layout. Coordinate W/6" PVC on Deck Drainage Plan, End Cross Frame and Trough Detail. Pitch at 4%.

WEST ABUTMENT DETAILS
STRUCTURE NO. 056-3190

DESIGNED	SSM
CHECKED	RGD
DRAWN	WJH
CHECKED	RGD

A-1-D 11-1-09

HRGreen
HRGreen.com
Illinois Professional Design Firm
184-001322

WB CHARLES J. MILLER ROAD BRIDGE		DATE: 7/23/12	
SHEET NO. S-27	F.A.U. RTE. 3860	SECTION 09-00372-00-PW	COUNTY McHENRY
S-41 SHEETS	TOTAL SHEETS 252		SHEET NO. 150
FED. ROAD DIST. NO. 1 ILLINOIS		CONTRACT NO. 63633	
FED. AID PROJECT			