

STATE OF ILLINOIS
DEPARTMENT OF TRANSPORTATION
DIVISION OF HIGHWAYS

F.A. RTE.	SECTION	COUNTY	TOTAL SHEETS	SHEET NO.
VAR	2014-078BR	WILL	24	1
		ILLINOIS	CONTRACT NO. 62A22	

FOR INDEX OF SHEETS, SEE SHEET NO. 2

IMPROVEMENTS ARE LOCATED IN THE CITY OF JOLIET.

TRAFFIC DATA

<p>LOC. 1: US 30 WB(CASS ST) SN 099-0101 2013 ADT = 16,000 SPEED LIMIT = 30 MPH</p>	<p>LOC. 4: IL 53 (RUBY ST) SN 099-9901 2013 ADT = 17,100 SPEED LIMIT = 30 MPH</p>
<p>LOC. 2: US 30 EB (JEFFERSON ST) SN 099-0166 2013 ADT = 11,400 SPEED LIMIT = 30 MPH</p>	<p>LOC. 5: BRANDON RD SN 099-9903 2012 ADT = 6,250 SPEED LIMIT = 35 MPH</p>
<p>LOC. 3: JACKSON ST SN 099-0239 2012 ADT = 3,000 SPEED LIMIT = 35 MPH</p>	<p>LOC. 6: US6/US 52 (McDONOUGH ST) SN 099-9904 2013 ADT = 10,700 SPEED LIMIT = 30 MPH</p>

PROPOSED
HIGHWAY PLANS

VARIOUS ROUTES
VARIOUS MOVEABLE BRIDGES
SECTION: 2014-078BR
BRIDGE REPAIRS
WILL COUNTY

C-91-105-15

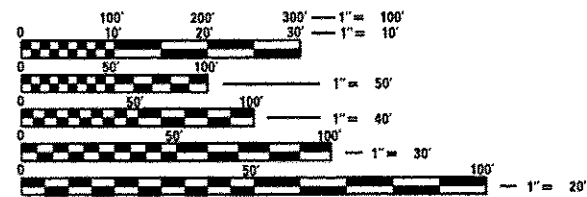
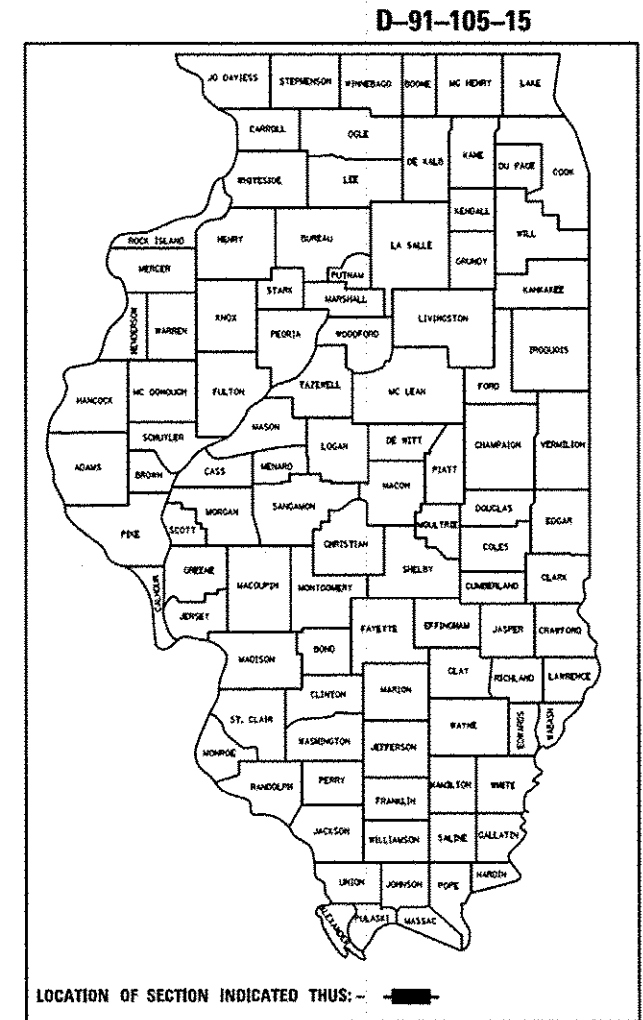

FULL SIZE PLANS HAVE BEEN PREPARED USING STANDARD ENGINEERING SCALES. REDUCED SIZED PLANS WILL NOT CONFORM TO STANDARD SCALES. IN MAKING MEASUREMENTS ON REDUCED PLANS, THE ABOVE SCALES MAY BE USED.

J.U.L.I.E.
JOINT UTILITY LOCATION INFORMATION FOR EXCAVATION
1-800-892-0123
OR 811

- LOCATION 1
SN 099-0101
US 30 WB (CASS ST)
OVER DES PLAINES RIVER
- LOCATION 2
SN 099-0166
US 30 EB (JEFFERSON ST)
OVER DES PLAINES RIVER
- LOCATION 5
SN 099-9903
BRANDON RD
OVER DES PLAINES RIVER

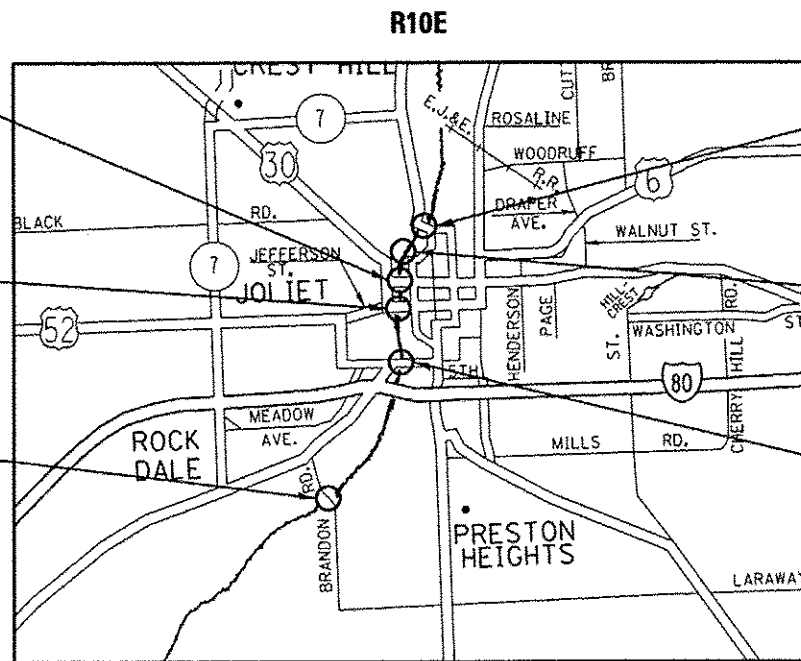

- LOCATION 4
SN 099-9901
IL 53 (RUBY ST)
OVER DES PLAINES RIVER
- LOCATION 3
SN 099-0239
JACKSON ST
OVER DES PLAINES RIVER
- LOCATION 6
SN 099-9904
US 64/US 52 (MCDONOUGH ST)
OVER DES PLAINES RIVER

JOLIET TOWNSHIP

PROJECT ENGINEER: ALAIN MIDY (847) 221-3056
PROJECT MANAGER: ISSAM RAYYAN (847) 705-4178

CONTRACT NO. 62A22

SINGH & ASSOCIATES, INC.
Date: 12/18/2014
SHEET NO: 10, 14, 15, 20, 21

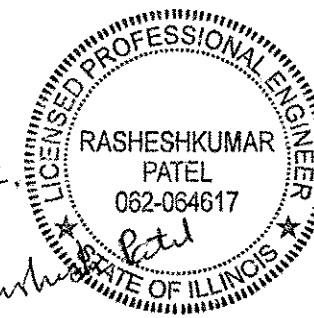

EXP. 11/30/15

STATE OF ILLINOIS
DEPARTMENT OF TRANSPORTATION
DIVISION OF HIGHWAYS

SUBMITTED December 22, 2014

John F. ...
DEPUTY DIRECTOR OF HIGHWAYS, REGION ENGINEER

Jan 30, 2015
John D. Baranzelli, P.E.
ENGINEER OF DESIGN AND ENVIRONMENT

Jan 30, 2015
Alien Osman, P.E.
DIRECTOR OF HIGHWAYS, CHIEF ENGINEER

PRINTED BY THE AUTHORITY
OF THE STATE OF ILLINOIS

INDEX OF SHEETS

1 TITLE SHEET
 2 INDEX OF SHEETS, STATE STANDARDS, AND GENERAL NOTES
 3-5 SUMMARY OF QUANTITIES
 6-9 DETOUR PLANS
 10 LOCATION 1: SN 099-0101
 11-14 LOCATION 2: SN 099-0166
 15 LOCATION 3: SN 099-0239
 16-20 LOCATION 4: SN 099-9901
 21 LOCATION 5: SN 099-9903
 22 LOCATION 6: SN 099-9904
 23 TRAFFIC CONTROL & PROTECTION FOR SIDE ROADS, INTERSECTIONS, & DRIVEWAYS (TC-10)
 24 ARTERIAL ROAD INFORMATION SIGN (TC-22)

STATE STANDARDS

701006-05 OFF-ROAD OPERATIONS, 2L, 2W, 15' TO 24" FROM PAVEMENT EDGE
 701101-04 OFF-ROAD OPERATIONS, MULTILANE, 15' TO 24" FROM PAVEMENT EDGE
 701301-04 LANE CLOSURE, 2L, 2W, SHORT TIME OPERATIONS
 701501-06 URBAN LANE CLOSURE, 2L, 2W, UNDIVIDED
 701601-09 URBAN LANE CLOSURE, MULTILANE, 1W OR 2W WITH NONTRAVERSABLE MEDIAN
 701606-10 URBAN SINGLE LANE CLOSURE, MULTILANE, 2W WITH MOUNTABLE MEDIAN
 701801-05 LANE CLOSURE, MULTILANE 1W OR 2W CROSSWALK OR SIDEWALK CLOSURE
 701901-04 TRAFFIC CONTROL DEVICES

GENERAL NOTES

BEFORE STARTING ANY EXCAVATION, THE CONTRACTOR SHALL CALL "J.U.L.I.E." AT (800) 892-0123 OR 811 FOR FIELD LOCATIONS OF BURIED ELECTRIC, TELEPHONE AND GAS UTILITIES. 48 HOUR NOTIFICATION IS REQUIRED.

THE CONTRACTOR SHALL COORDINATE CONSTRUCTION ACTIVITIES WITH UTILITY COMPANIES, AND THE CITY OF JOLIET.

PLAN DIMENSIONS AND DETAILS RELATIVE TO EXISTING PLANS ARE SUBJECT TO NOMINAL CONSTRUCTION VARIATIONS. THE CONTRACTOR SHALL FIELD VERIFY EXISTING DIMENSIONS AND DETAILS AFFECTING NEW CONSTRUCTION AND MAKE NECESSARY APPROVED ADJUSTMENTS PRIOR TO CONSTRUCTION OR ORDERING OF MATERIALS. SUCH VARIATIONS SHALL NOT BE CAUSE FOR ADDITIONAL COMPENSATION FOR A CHANGE IN SCOPE OF THE WORK. HOWEVER, THE CONTRACTOR WILL BE PAID FOR THE QUANTITY ACTUALLY FURNISHED BASED AT THE UNIT PRICE BID FOR THE WORK.

THE CONTRACTOR SHALL CONTACT THE DISTRICT ONE TRAFFIC CONTROL SUPERVISOR AT (847)705-4470 A MINIMUM OF 72 HOURS IN ADVANCE OF BEGINNING WORK.

THESE PLANS HAVE BEEN PREPARED FROM NOTES RECEIVED FROM THE BUREAU OF MAINTENANCE (BRIDGE INSPECTORS)

DO NOT SCALE PLANS FOR CONSTRUCTION DIMENSIONS.

THE CONTRACTOR SHALL TAKE NECESSARY PRECAUTIONS TO ENSURE THAT NO DEBRIS WILL ENDANGER OR INTERFERE WITH RIVER TRAFFIC BENEATH THE BRIDGE(S). THIS WORK WILL NOT BE PAID FOR SEPERATELY, BUT SHALL BE INCLUDED IN THE CONTRACT UNIT PRICE FOR THE APPROPRIATE PAY ITEM INVOLVED AND NO ADDITIONAL COMPENSATION WILL BE ALLOWED

THE CONTRACTOR SHALL OBTAIN COAST GUARD APPROVAL FOR ANY WORK THAT MAY INTERFERE WITH NAVIGATIONAL OPERATIONS OF THE NAVIGABLE WATERS. A WORK PLAN SHALL BE PREPARED BY THE CONTRACTOR, REVIEWED AND APPROVED BY THE ENGINEER AND BE SUBMITTED BY THE ENGINEER TO THE COAST GUARD AT THE ADDRESS LISTED BELOW FOR APPROVAL.

SCOTT STRIFFLER - BRIDGE ADMINISTRATOR
 (216) 902-6085
 US COAST GUARD
 NINTH COAST GUARD DISTRICT
 1240 E. NINTH ST
 CLEVELAND, OH 44199-2060

THE DEPARTMENT HAS DETERMINED THAT IN STREAM WORK IS NOT REQUIRED FOR THE WORK SPECIFIED IN THIS CONTRACT. THE DEPARTMENT HAS NOT OBTAINED A 404 PERMIT. IF THE CONTRACTOR CHOOSES TO USE ACTIVITIES REQUIRING AN USACE 404 PERMIT IT IS THE CONTRACTOR'S RESPONSIBILITY TO SECURE THE PROPER USACE PERMITS.

FILE NAME =	USER NAME = asbornnp	DESIGNED -	REVISED -	STATE OF ILLINOIS DEPARTMENT OF TRANSPORTATION	INDEX, STATE STANDARDS, AND GENERAL NOTES	F.A. RTE.	SECTION	COUNTY	TOTAL SHEETS	SHEET NO.	
at:\p\work\pedit\asbornnp\0417055\01	0515-akt-cover.dgn	DRAWN -	REVISED -			VARIES	2014-078BR	WILL	24	2	
	PLOT SCALE = 100.0000 1/ in.	CHECKED -	REVISED -			CONTRACT NO. 62A22					
Default	PLOT DATE = 12/17/2014	DATE -	REVISED -			SCALE:	SHEET	OF	SHEETS	STA.	TO STA.

BRIDGE CLOSED
XX MILES AHEAD
LOCAL TRAFFIC ONLY

BRIDGE
CLOSED

① R11-2 (48" x 30")

② R11-3a (60" x 30")

DETOUR



③ M4-8-2412

④ M1-40-2424

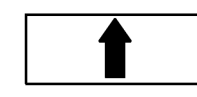

⑤ M6-3-2115

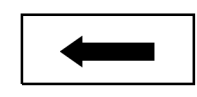

⑥L M6-1L-2115

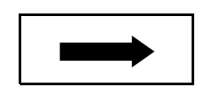

⑥R M6-1R-2115

EAST

⑦E M3-2-2412

WEST

⑦W M3-4-2412

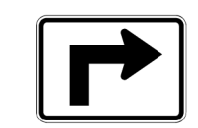

⑧R M5-1R-2115



⑧L M5-1L-2115



⑨R M4-10R (48"x18")



⑨L M4-10L (48"x18")

END
DETOUR

⑩ M4-8A (24" x 18")

SIDEWALK
CLOSED

⑪ R11-1101

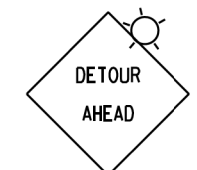

⑫ W20-2 (48" X 48")



⑬ W20-3 (48" X 48")

LEGEND:

- DETOUR ROUTE
- CONSTRUCTION ZONE
- TYPE III BARRICADE
- AMBER FLASHING LIGHT

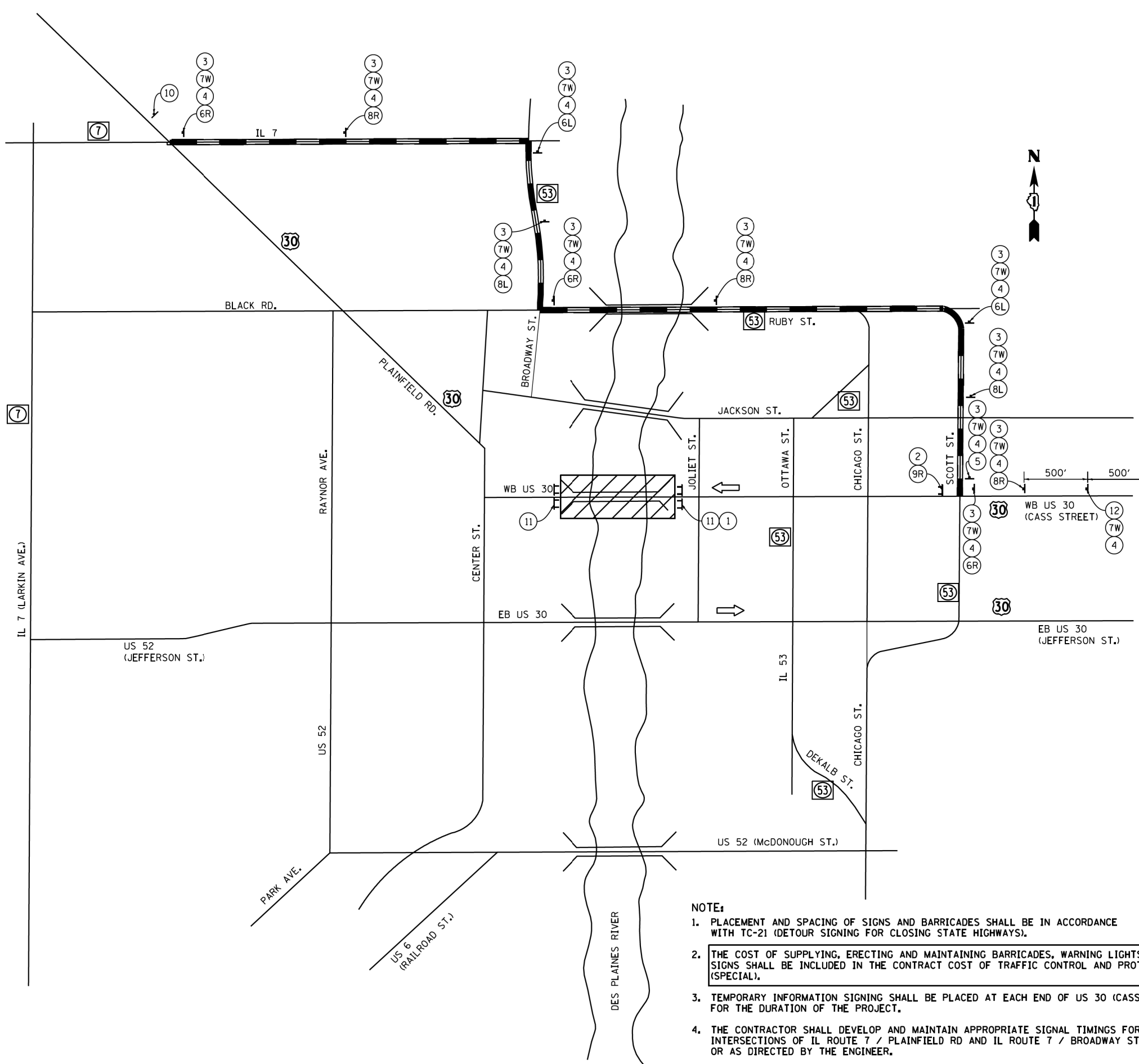

NOTE:

1. PLACEMENT AND SPACING OF SIGNS AND BARRICADES SHALL BE IN ACCORDANCE WITH TC-21 (DETOUR SIGNING FOR CLOSING STATE HIGHWAYS).
2. THE COST OF SUPPLYING, ERECTING AND MAINTAINING BARRICADES, WARNING LIGHTS AND SIGNS SHALL BE INCLUDED IN THE CONTRACT COST OF TRAFFIC CONTROL AND PROTECTION (SPECIAL).
3. TEMPORARY INFORMATION SIGNING SHALL BE PLACED AT EACH END OF US 30 (CASS ST.) FOR THE DURATION OF THE PROJECT.
4. THE CONTRACTOR SHALL DEVELOP AND MAINTAIN APPROPRIATE SIGNAL TIMINGS FOR THE INTERSECTIONS OF IL ROUTE 7 / PLAINFIELD RD AND IL ROUTE 7 / BROADWAY ST., OR AS DIRECTED BY THE ENGINEER.

FILE NAME =	USER NAME = mremper	DESIGNED - JMS	REVISED -
It\8274 - IDOT PTB 168 - 07 Various\8274	09 - Movable Bridge Electrical\CADD\CADD SHEETS	DRAWN US 30 DETOUR	REVISED -
	PLOT SCALE = 48,0000' / in.	CHECKED - JMH	REVISED -
	PLOT DATE = 11/13/2014	DATE - NOVEMBER, 2014	REVISED -

STATE OF ILLINOIS
DEPARTMENT OF TRANSPORTATION

DETOUR PLAN			
US 30 WB (CASS STREET) - S.N. 099-0101			
SCALE:	SHEET NO.	OF SHEETS	STA. TO STA.

F.A.P. RTE.	SECTION	COUNTY	TOTAL SHEETS	SHEET NO.
VAR.	2014-0788R	VAR.	24	6
CONTRACT NO. 62A22				
ILLINOIS FED. AID PROJECT				

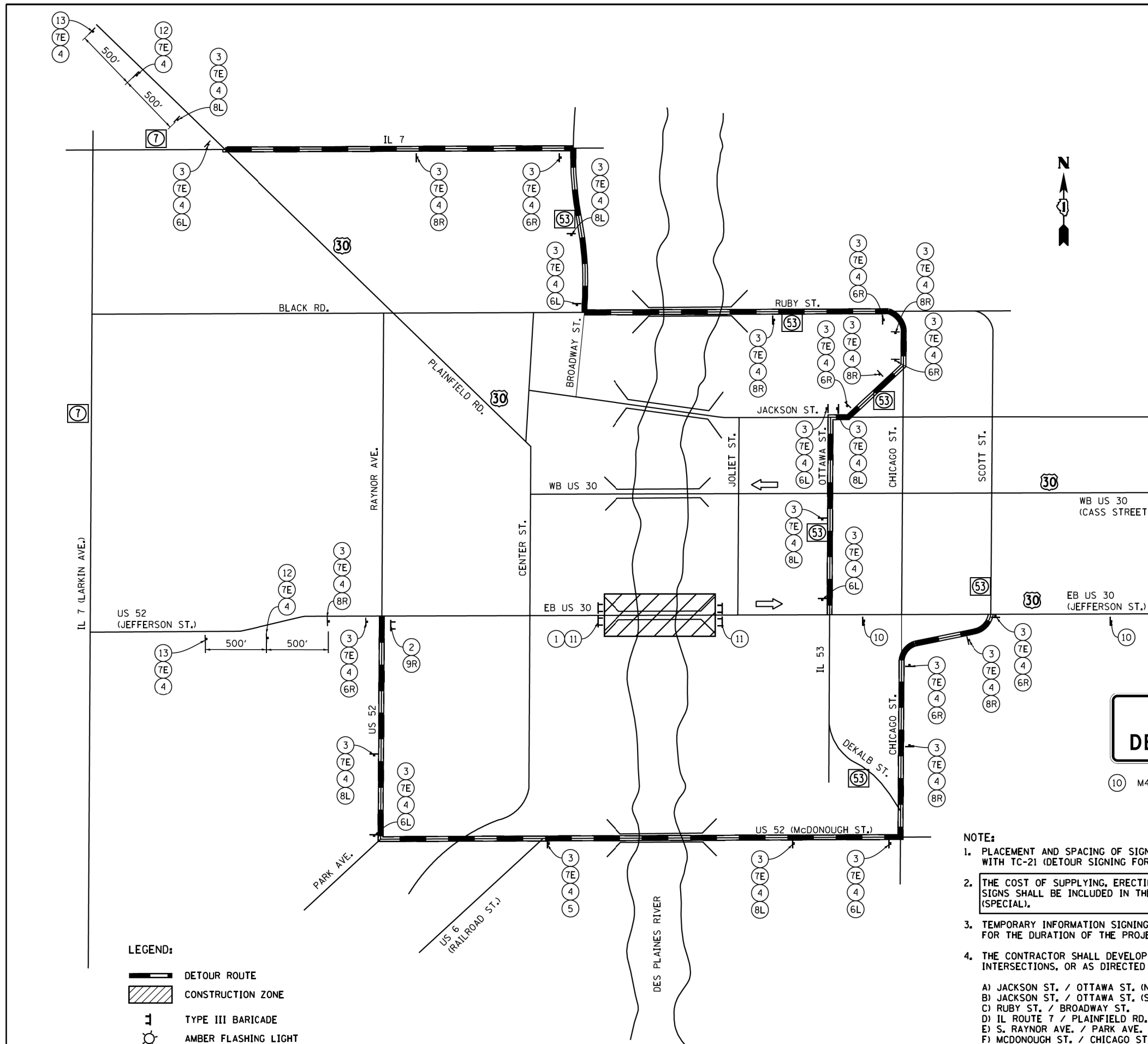

BRIDGE CLOSED

① R11-2 (48" x 30")

BRIDGE CLOSED XX MILES AHEAD LOCAL TRAFFIC ONLY

② R11-3a (60" x 30")

DETOUR

③ M4-8-2412

④ M1-40-2424

⑤ M6-3-2115

⑥ M6-1L-2115

⑥R M6-1R-2115

EAST

⑦E M3-2-2412

WEST

⑦W M3-4-2412

⑧R M5-1R-2115

⑧L M5-1L-2115

DETOUR →

⑨R M4-10R (48"x18")

DETOUR ←

⑨L M4-10L (48"x18")

END DETOUR

⑩ M4-8A (24" x 18")

SIDEWALK CLOSED

⑪ R11-1101

DETOUR AHEAD

⑫ W20-2 (48" x 48")

ROAD CLOSED AHEAD

⑬ W20-3 (48" x 48")

- LEGEND:**
- DETOUR ROUTE
 - CONSTRUCTION ZONE
 - TYPE III BARRICADE
 - AMBER FLASHING LIGHT

- NOTE:**
1. PLACEMENT AND SPACING OF SIGNS AND BARRICADES SHALL BE IN ACCORDANCE WITH TC-21 (DETOUR SIGNING FOR CLOSING STATE HIGHWAYS).
 2. THE COST OF SUPPLYING, ERECTING AND MAINTAINING BARRICADES, WARNING LIGHTS AND SIGNS SHALL BE INCLUDED IN THE CONTRACT COST OF TRAFFIC CONTROL AND PROTECTION (SPECIAL).
 3. TEMPORARY INFORMATION SIGNING SHALL BE PLACED AT EACH END OF EB US 30 (JEFFERSON ST.) FOR THE DURATION OF THE PROJECT.
 4. THE CONTRACTOR SHALL DEVELOP AND MAINTAIN APPROPRIATE SIGNAL TIMINGS FOR THE FOLLOWING INTERSECTIONS, OR AS DIRECTED BY THE ENGINEER
 - A) JACKSON ST. / OTTAWA ST. (NORTH LEG)
 - B) JACKSON ST. / OTTAWA ST. (SOUTH LEG)
 - C) RUBY ST. / BROADWAY ST.
 - D) IL ROUTE 7 / PLAINFIELD RD.
 - E) S. RAYNOR AVE. / PARK AVE.
 - F) MCDONOUGH ST. / CHICAGO ST.

FILE NAME = It\8274 - IDOT PTB 168 - 07 Various\8274	USER NAME = mramper	DESIGNED - JMS	REVISED -	STATE OF ILLINOIS DEPARTMENT OF TRANSPORTATION	DETOUR PLAN			F.A. RTE.	SECTION	COUNTY	TOTAL SHEETS	SHEET NO.
					US 30 EB (JEFFERSON STREET) - S.N. 099-0166			VAR.	2014-078BR	VAR.	24	7
					SCALE: SHEET NO. OF SHEETS STA. TO STA.			CONTRACT NO. 62A22				
					ILLINOIS FED. AID PROJECT							

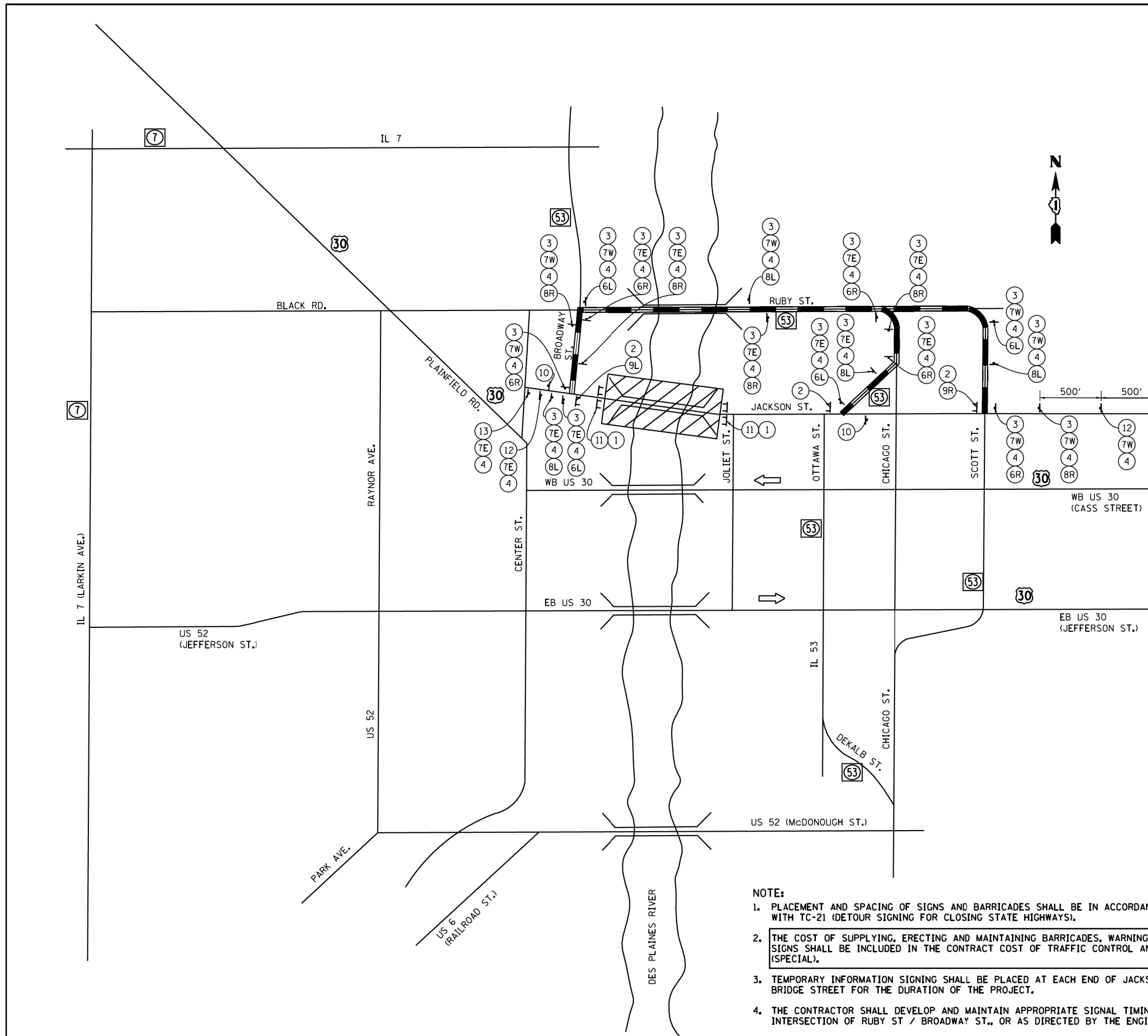

BRIDGE CLOSED

① R11-2 (48" x 30")

DETOUR

③ M4-8-2412

⑤ M6-3-2115

⑥L M6-1L-2115

⑥R M6-1R-2115

⑦E M3-2-2412

⑦W M3-4-2412

⑧R M5-1R-2115

⑧L M5-1L-2115

⑨R M4-10R (48"x18")

⑨L M4-10L (48"x18")

⑩ M4-8A (24" x 18")

⑫ W20-2 (48" X 48")

**BRIDGE CLOSED
XX MILES AHEAD
LOCAL TRAFFIC ONLY**

② R11-3a (60" x 30")

**JACKSON ST
BRIDGE ST**

BORDER
R=1.5"
TH=0.63"
IN=0.47"

④ 4" BLACK LETTERS ON
ORANGE REFLECTIVE BACKGROUND

EAST

⑦E M3-2-2412

WEST

⑦W M3-4-2412

DETOUR (Right Turn)

⑧R M5-1R-2115

DETOUR (Left Turn)

⑧L M5-1L-2115

DETOUR (Straight)

⑨R M4-10R (48"x18")

⑨L M4-10L (48"x18")

**END
DETOUR**

⑩ M4-8A (24" x 18")

**SIDEWALK
CLOSED**

⑪ R11-1101

**DETOUR
AHEAD**

⑫ W20-2 (48" X 48")

**ROAD
CLOSED
AHEAD**

⑬ W20-3 (48" X 48")

LEGEND:

- DETOUR ROUTE
- CONSTRUCTION ZONE
- TYPE III BARRICADE
- AMBER FLASHING LIGHT

NOTE:

1. PLACEMENT AND SPACING OF SIGNS AND BARRICADES SHALL BE IN ACCORDANCE WITH TC-21 (DETOUR SIGNING FOR CLOSING STATE HIGHWAYS).
2. THE COST OF SUPPLYING, ERECTING AND MAINTAINING BARRICADES, WARNING LIGHTS AND SIGNS SHALL BE INCLUDED IN THE CONTRACT COST OF TRAFFIC CONTROL AND PROTECTION (SPECIAL).
3. TEMPORARY INFORMATION SIGNING SHALL BE PLACED AT EACH END OF JACKSON STREET AND BRIDGE STREET FOR THE DURATION OF THE PROJECT.
4. THE CONTRACTOR SHALL DEVELOP AND MAINTAIN APPROPRIATE SIGNAL TIMINGS FOR THE INTERSECTION OF RUBY ST / BROADWAY ST., OR AS DIRECTED BY THE ENGINEER.

FILE NAME =	USER NAME = mremper	DESIGNED - JMS	REVISED -	STATE OF ILLINOIS DEPARTMENT OF TRANSPORTATION	DETOUR PLAN JACKSON STREET - S.N. 099-0239				F.A. RTE.	SECTION	COUNTY	TOTAL SHEETS	SHEET NO.	
It\8274 - IDOT PTB 168 - 07 Various\8274	09 - Movable Bridge Electrical\CADD\CADD SHEETS	DRAWN BY SF DE PERL	REVISED -		SCALE:	SHEET NO.	OF	SHEETS	STA.	TO	STA.	VAR.	24	8
	PLOT SCALE = 48,0000' / in.	CHECKED - JMH	REVISED -		CONTRACT NO. 62A22									
	PLOT DATE = 11/13/2014	DATE - NOVEMBER, 2014	REVISED -		ILLINOIS FED. AID PROJECT									

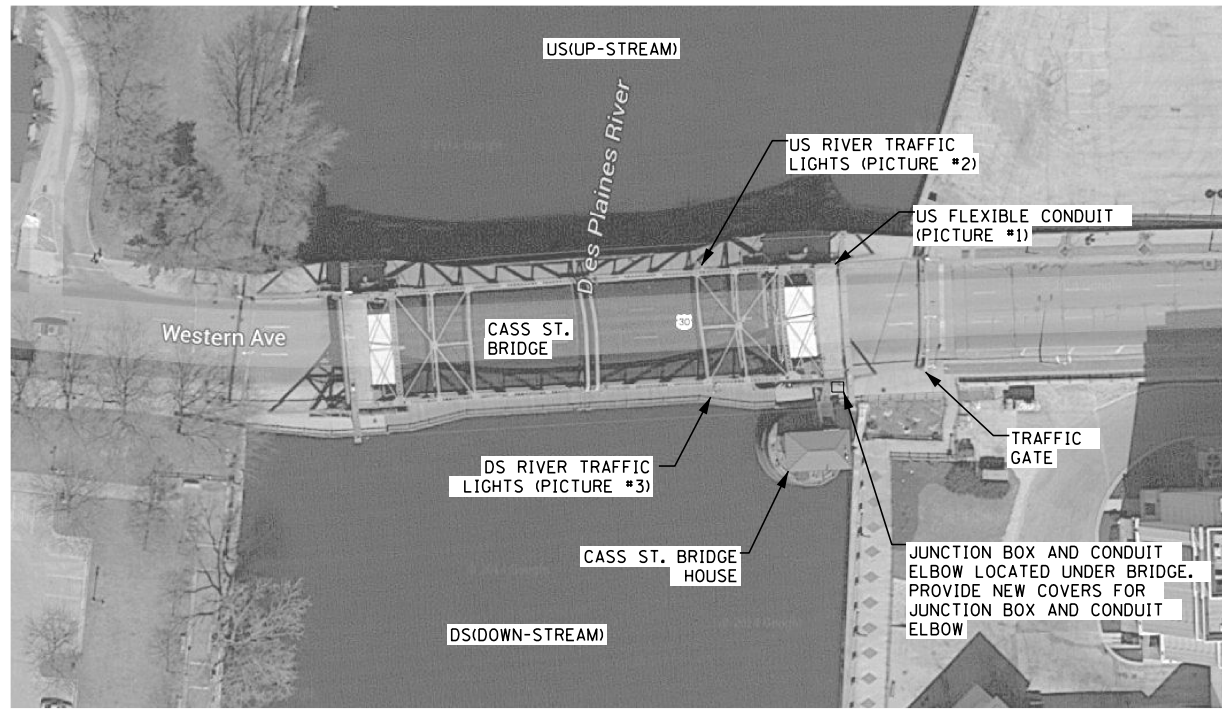

CASS STREET PLAN VIEW
N.T.S

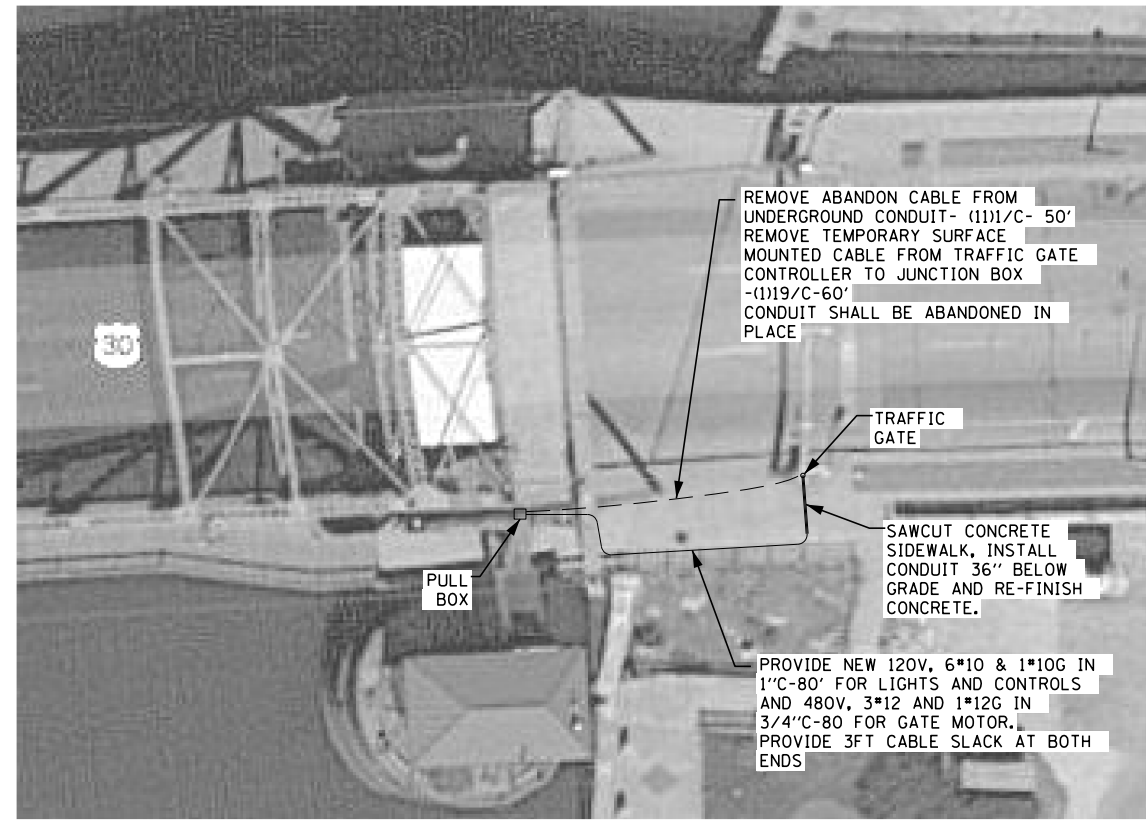

CASS STREET EAST SIDE ENLARGED PLAN VIEW
N.T.S

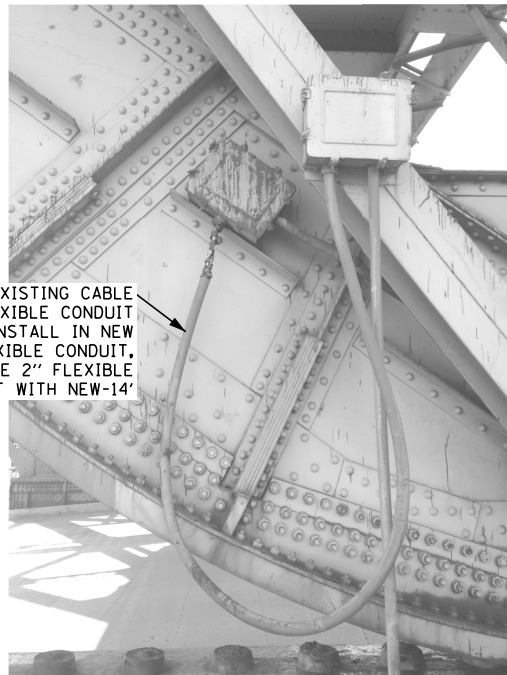

PICTURE #1: US FLEXIBLE CONDUIT
N.T.S



PICTURE #2: US RIVER TRAFFIC LIGHTS
N.T.S

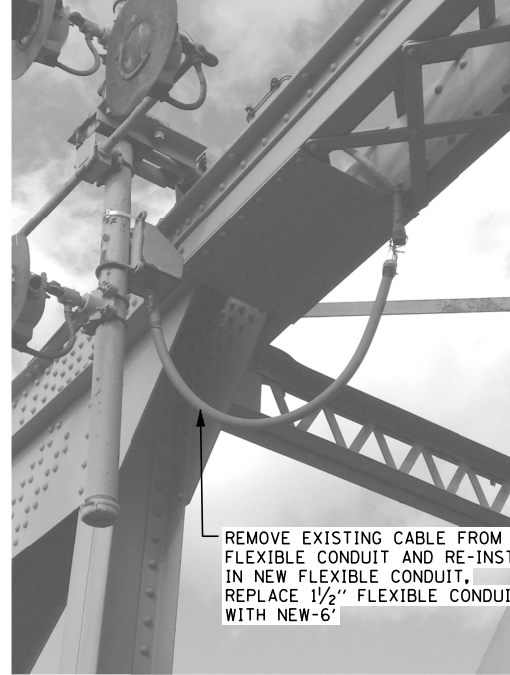

PICTURE #3: DS RIVER TRAFFIC LIGHTS
N.T.S

SCHEDULE OF QUANTITIES

ITEM	UNIT	099-0101 CASS BRIDGE
SIDEWALK REMOVAL	SQ FT	12
PORTLAND CEMENT CONCRETE SIDEWALK 5 INCH	SQ FT	12
CONDUIT ATTACHED TO STRUCTURE, 3/4" DIA., PVC COATED GALVANIZED STEEL	FOOT	80
CONDUIT ATTACHED TO STRUCTURE, 1" DIA., PVC COATED GALVANIZED STEEL	FOOT	80
ELECTRIC CABLE IN CONDUIT, 600V (XLP-TYPE USE) 1/C NO. 12	FOOT	344
ELECTRIC CABLE IN CONDUIT, 600V (XLP-TYPE USE) 1/C NO. 10	FOOT	602
REMOVE ELECTRIC CABLE FROM CONDUIT	FOOT	688
REMOVE CONDUIT ATTACHED TO STRUCTURE	FOOT	26
CONDUIT, FLEXIBLE, LIQUID TIGHT, METALLIC 1 1/2" DIA.	FOOT	12
CONDUIT, FLEXIBLE, LIQUID TIGHT, METALLIC 2" DIA.	FOOT	14
ELBOW CONDUIT COVER	EACH	1
JUNCTION BOX COVER	EACH	1

I:\11589\10_9\10\11\CADD_Sheets\14-Cass St Bridge.dgn
06-JAN-2015 09:28:15



USER NAME = kprajapati	DESIGNED - HS	REVISED
PLOT SCALE = 100.000000:1.000000	DRAWN - HS	REVISED
PLOT DATE = 06-JAN-2015 10:12	CHECKED - KGP	REVISED
	DATE - 11/14/2014	REVISED

**STATE OF ILLINOIS
DEPARTMENT OF TRANSPORTATION**

ELECTRICAL REPAIRS: SN 099-0101			
LOC 1:CASS ST BRIDGE OVER DES PLAINES RIVER			
SCALE: AS NOTED	SHEET NO.	OF SHEETS	STA. TO STA.

F.A.I. RTE.	SECTION	COUNTY	TOTAL SHEETS	SHEET NO.
VAR.	2014-078BR	VAR.	24	10
			CONTRACT NO. 62A22	
ILLINOIS FED. AID PROJECT				

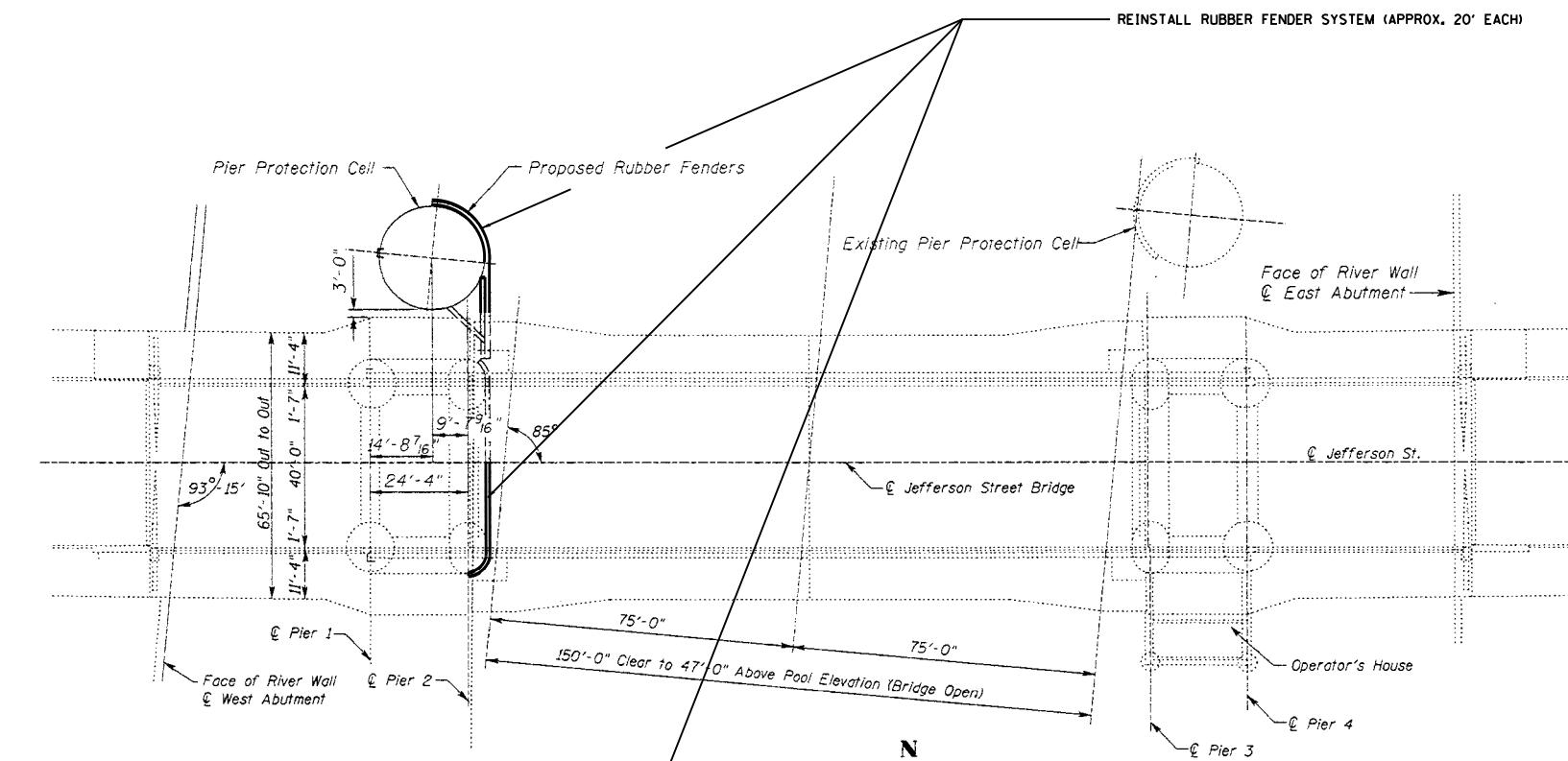

PLAN

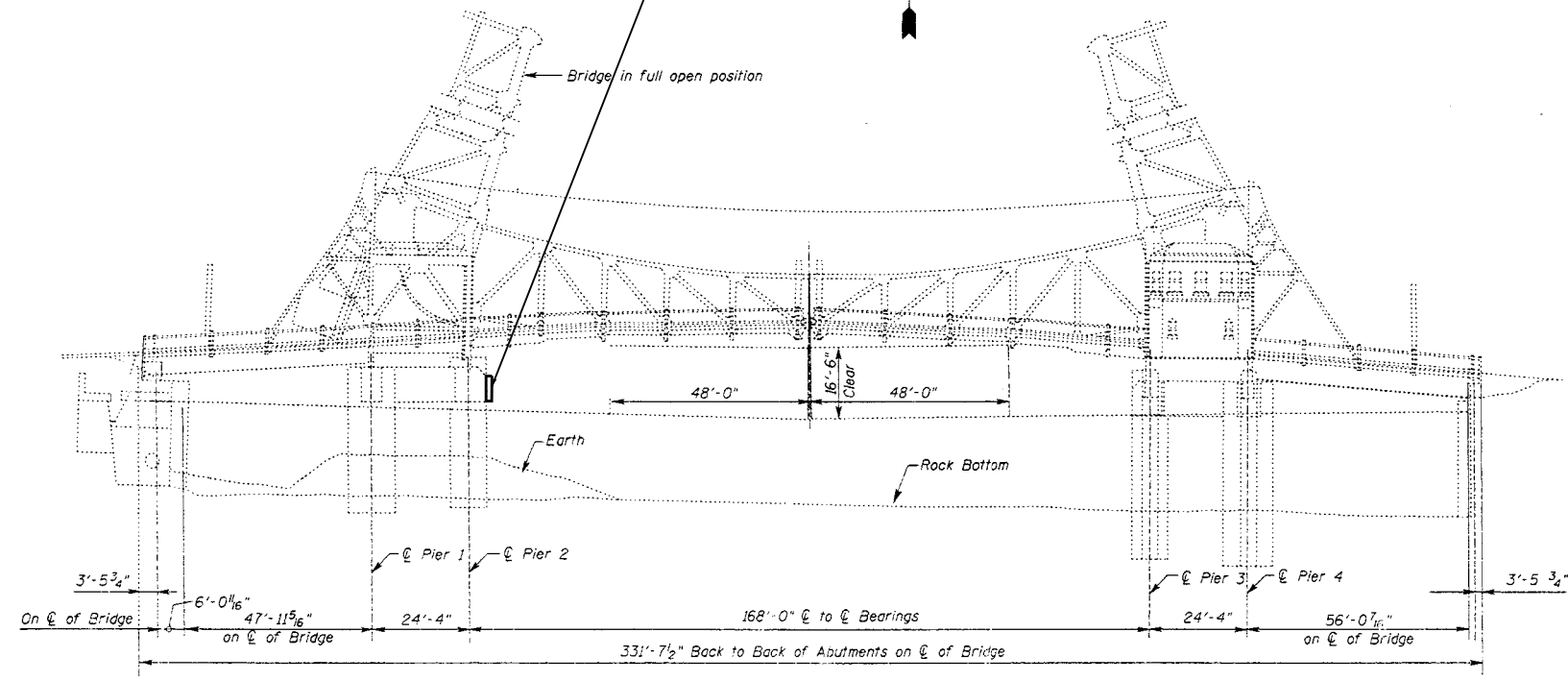

ELEVATION

REINSTALL RUBBER FENDER SYSTEM (APPROX. 20' EACH)

SCHEDULE OF QUANTITIES

ITEM	UNIT	TOTAL
REINSTALL RUBBER FENDER SYSTEM	L SUM	0.7

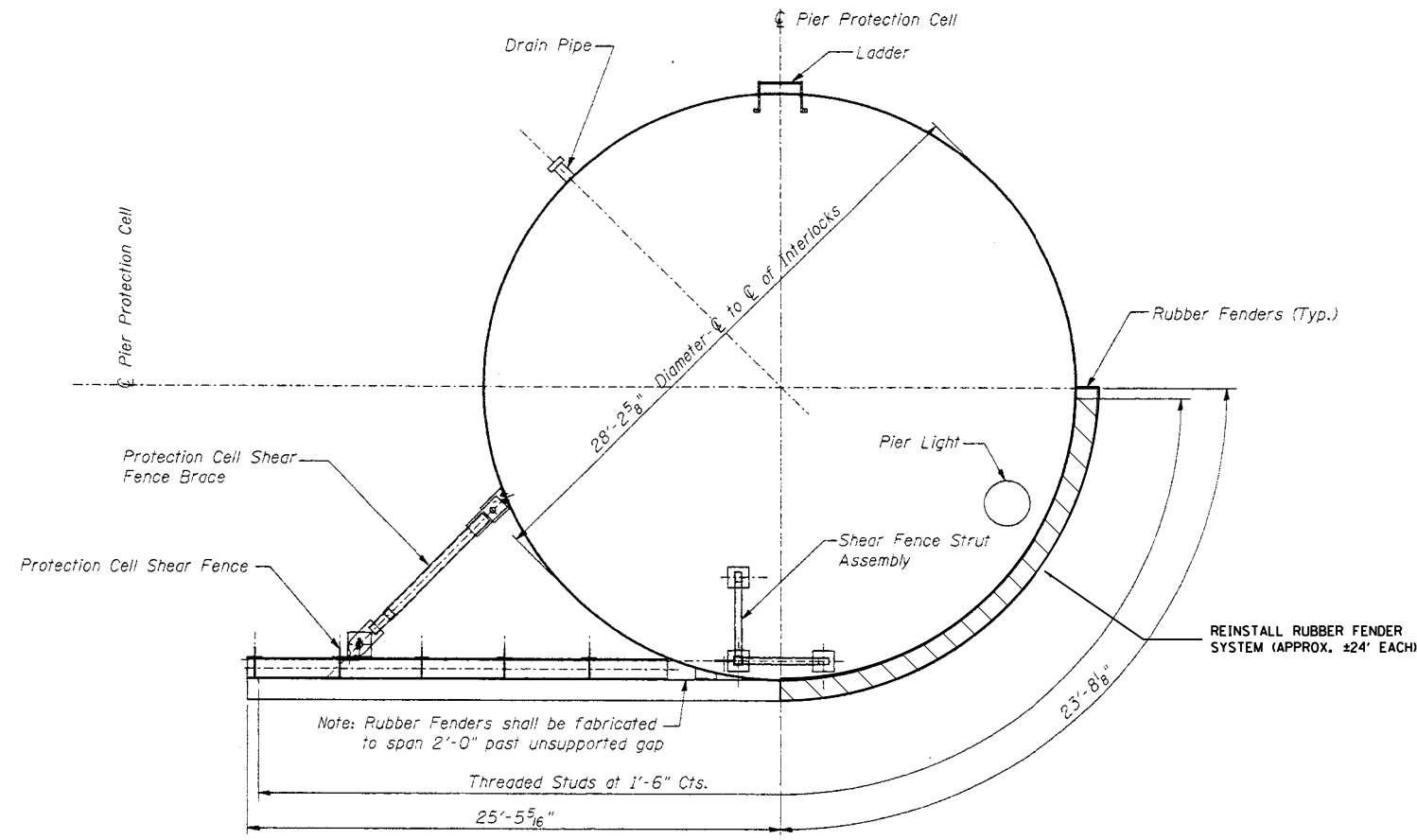

PLAN

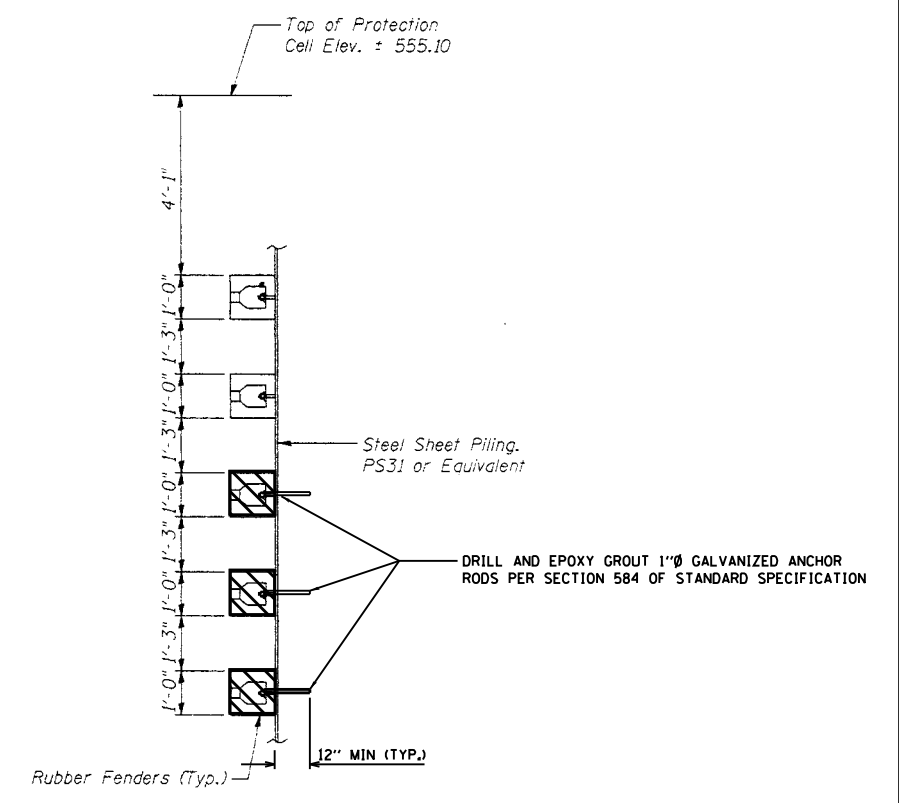

SECTION M-M

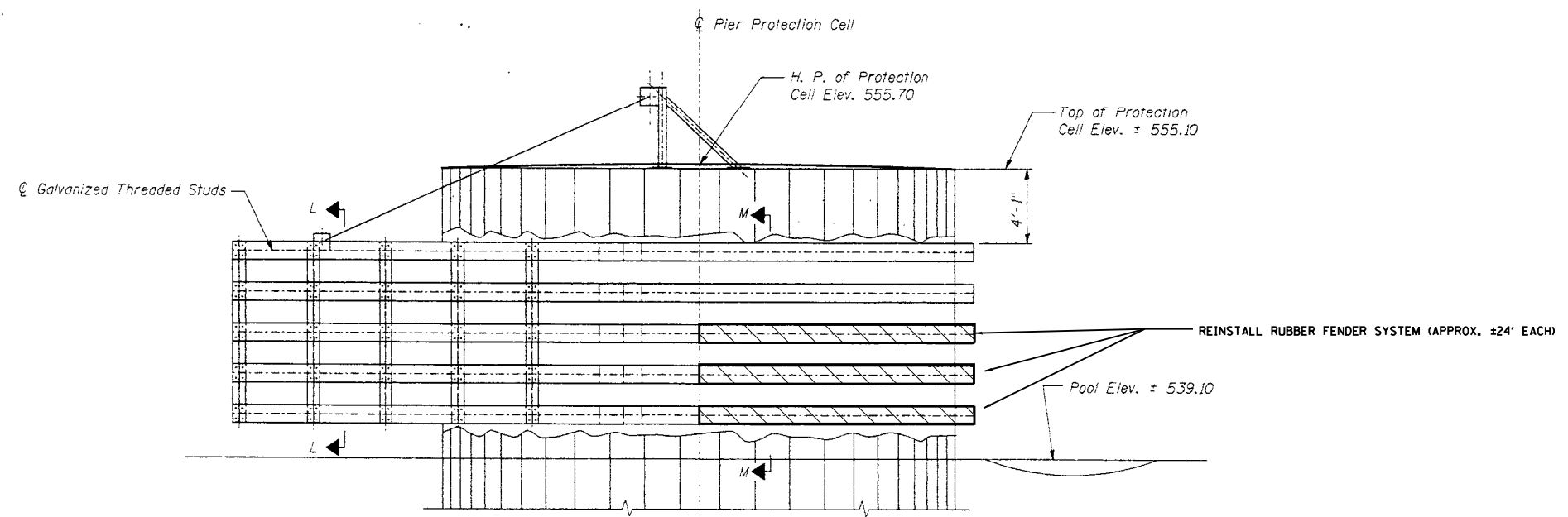

ELEVATION

FILE NAME =	USER NAME = osbornnp	DESIGNED -	REVISED -	STATE OF ILLINOIS DEPARTMENT OF TRANSPORTATION	FENDER REPAIRS: SN 099-0166			F.A. RTÉ.	SECTION	COUNTY	TOTAL SHEETS	SHEET NO.
Default	et:\pwork\pwork\osbornnp\d0417055\DI0515-sht-cover.dgn	DRAWN -	REVISED -		LOC 2: JEFFERSON ST BRIDGE (US 30 EB) OVER DES PLAINES RIVER RD			VAR	2014-078BR	WILL	24	12
	PLOT SCALE = 100.0000' / 1in.	CHECKED -	REVISED -		SCALE: SHEET OF SHEETS STA. TO STA.			CONTRACT NO. 62A22				
	PLOT DATE = 12/17/2014	DATE -	REVISED -		ILLINOIS FED. AID PROJECT							

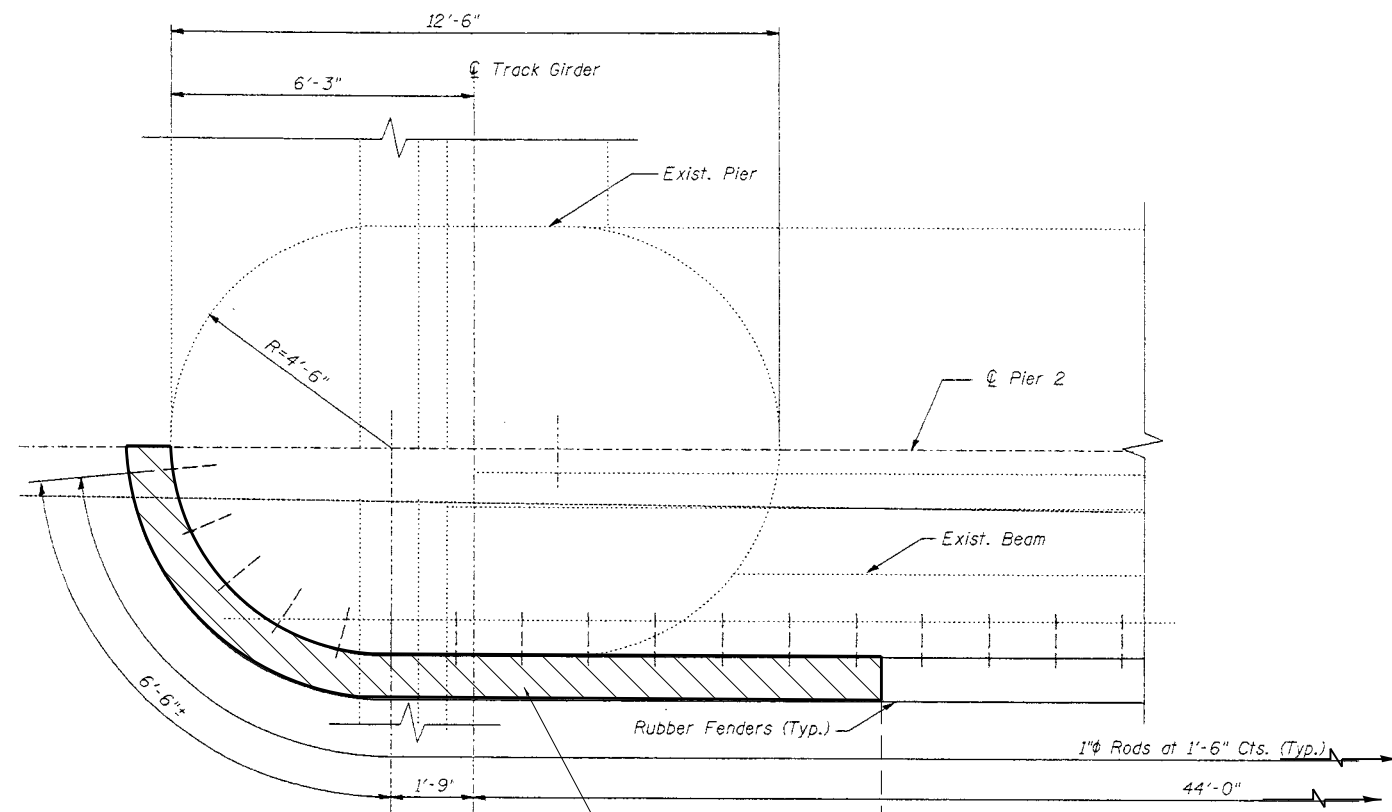

REINSTALL RUBBER FENDER SYSTEM (APPROX. 20' EACH) **PLAN**

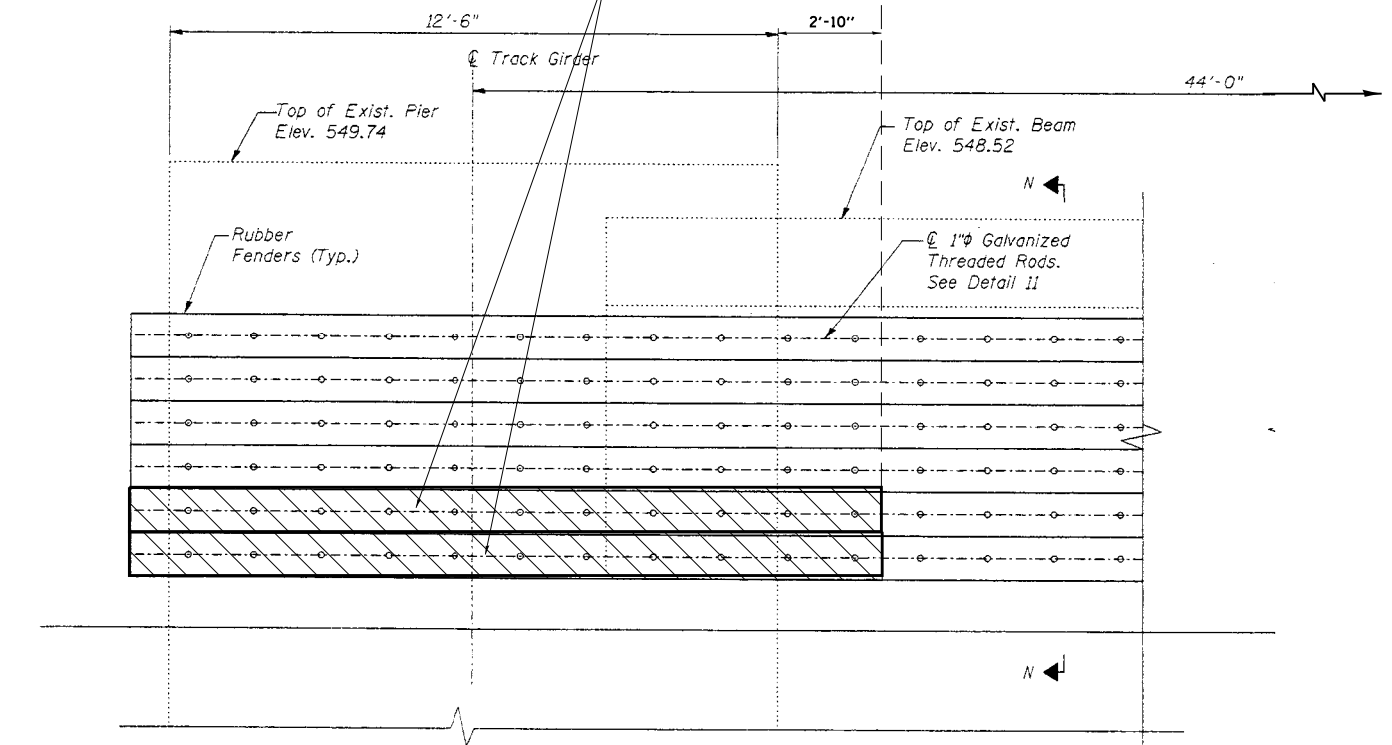

ELEVATION

Note:
Remove Existing Timber Fenders from Pier 2
prior to installation of Rubber Fenders

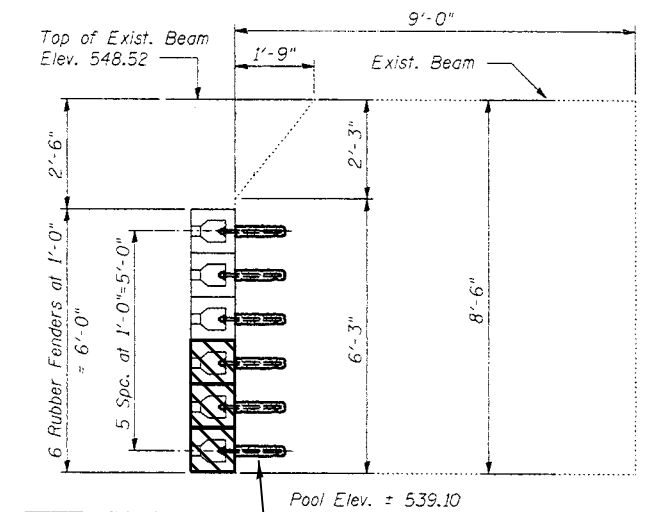

1" GALVANIZED ASTM
A307 Gr. C
THREADED RODS

SECTION N-N

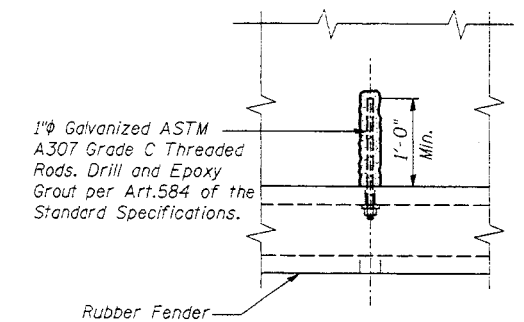

DETAIL-11

FILE NAME =	USER NAME = osbornnp	DESIGNED -	REVISED -
et:\pw\work\p\dot\osbornnp\d0417055\DI0515-sht-cover.dgn		DRAWN -	REVISED -
Default	PLOT SCALE = 100.0000' / in.	CHECKED -	REVISED -
	PLOT DATE = 12/17/2014	DATE -	REVISED -

STATE OF ILLINOIS
DEPARTMENT OF TRANSPORTATION

FENDER REPAIRS: SN 099-0166
LOC 2: JEFFERSON ST BRIDGE (US 30 EB) OVER DES PLAINES RIVER RD

SCALE: SHEET OF SHEETS STA. TO STA.

F.A. RTE.	SECTION	COUNTY	TOTAL SHEETS	SHEET NO.
VAR	2014-078BR	WILL	24	13
CONTRACT NO. 62A22				
ILLINOIS FED. AID PROJECT				

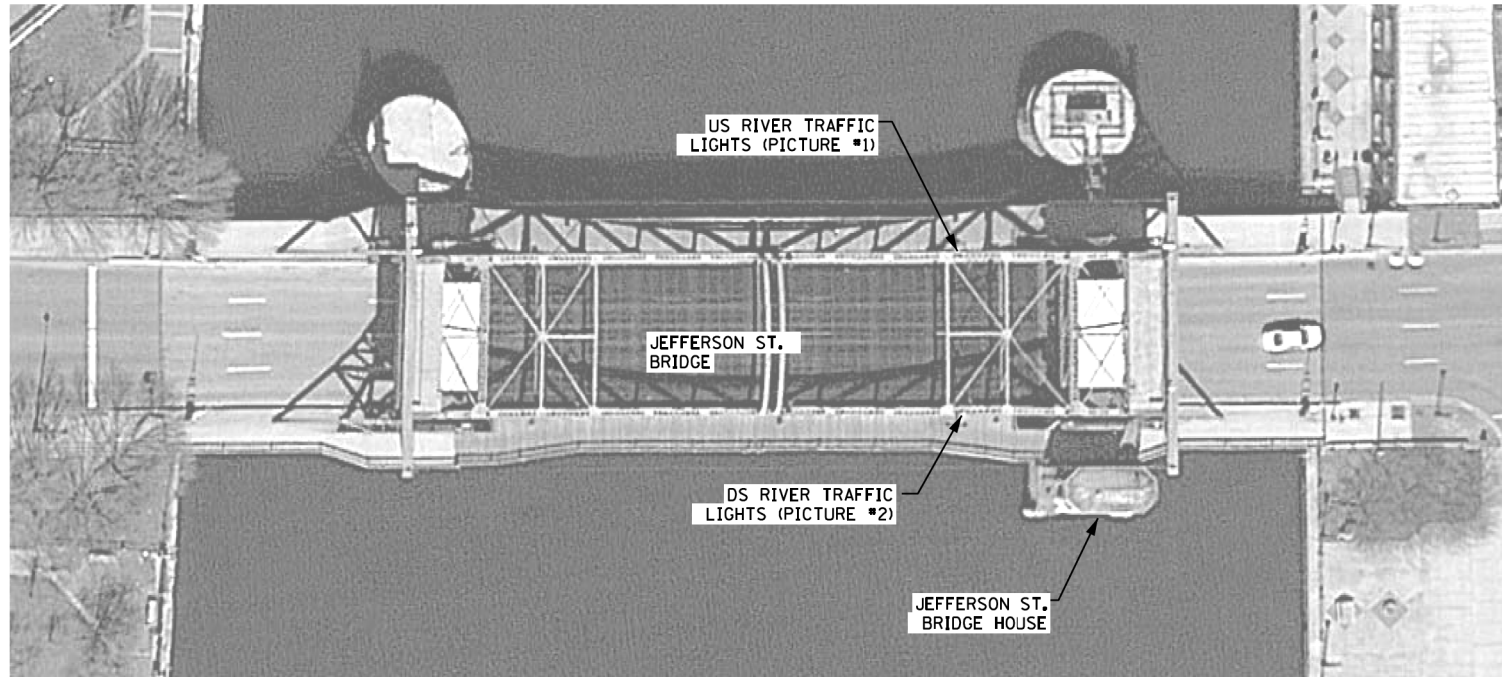

JEFFERSON STREET PLAN VIEW
N.T.S

SCHEDULE OF QUANTITIES

ITEM	UNIT	099-0166 JEFFERSON BRIDGE
ELECTRIC CABLE IN CONDUIT, 600V (XLP-TYPE USE) 1/C NO. 10	FOOT	90
REMOVE ELECTRIC CABLE FROM CONDUIT	FOOT	30
REMOVE CONDUIT ATTACHED TO STRUCTURE	FOOT	20
CONDUIT, FLEXIBLE, LIQUID TIGHT, METALLIC 2" DIA.	FOOT	20

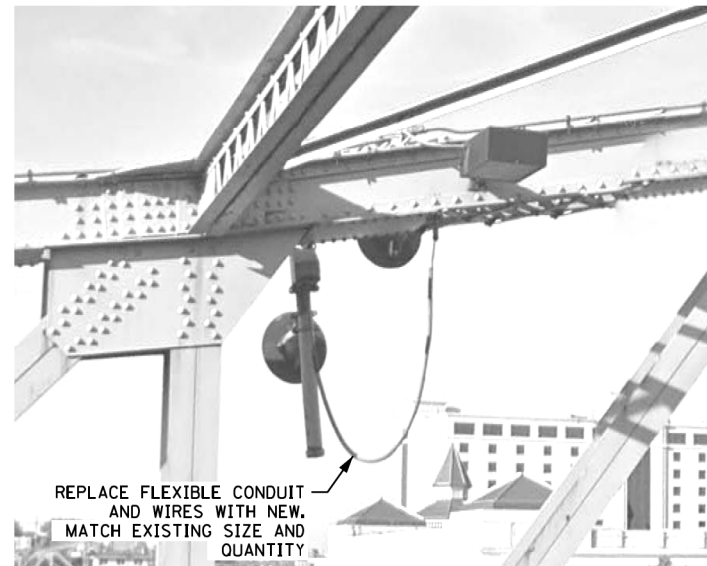

PICTURE #1: US RIVER TRAFFIC LIGHTS
N.T.S



PICTURE #2: DS RIVER TRAFFIC LIGHTS
N.T.S

S:\FILES\WG\EN\DRN\CADD_Sheets\ES-Jefferson St Bridge.dgn 09-DEC-2014 17:02 TIME\$



USER NAME = kprajapati	DESIGNED - HS	REVISED
	DRAWN - HS	REVISED
PLOT SCALE = 100.000000/1.000000	CHECKED - KGP	REVISED
PLOT DATE = 09-DEC-2014 17:02	DATE - 11/14/2014	REVISED

**STATE OF ILLINOIS
DEPARTMENT OF TRANSPORTATION**

JEFFERSON STREET BRIDGE OVER DES PLAINES RIVER

SCALE: AS NOTED SHEET NO. 5 OF 5 SHEETS STA. TO STA.

F.A.I. RTE.	SECTION	COUNTY	TOTAL SHEETS	SHEET NO.
VAR.	2014-078BR	VAR.	24	14
			CONTRACT NO. 62A22	
ILLINOIS FED. AID PROJECT				

SCHEDULE OF QUANTITIES

ITEM	UNIT	099-0239 JACKSON BRIDGE
ELECTRIC UTILITY SERVICE CONNECTION	L SUM	1
CONDUIT ATTACHED TO STRUCTURE, 3/4" DIA., PVC COATED GALVANIZED STEEL	FOOT	120
CONDUIT ATTACHED TO STRUCTURE, 1" DIA., PVC COATED GALVANIZED STEEL	FOOT	120
ELECTRIC CABLE IN CONDUIT, 600V (XLP-TYPE USE) 1/C NO. 12	FOOT	480
ELECTRIC CABLE IN CONDUIT, 600V (XLP-TYPE USE) 1/C NO. 10	FOOT	840
REMOVE ELECTRIC CABLE FROM CONDUIT	FOOT	440
REMOVE CONDUIT ATTACHED TO STRUCTURE	FOOT	240
REPAIR GEAR REDUCER ASSEMBLY (SPECIAL)	EACH	1
REMOVE AND REPLACE CAM LIMIT SWITCH	EACH	1

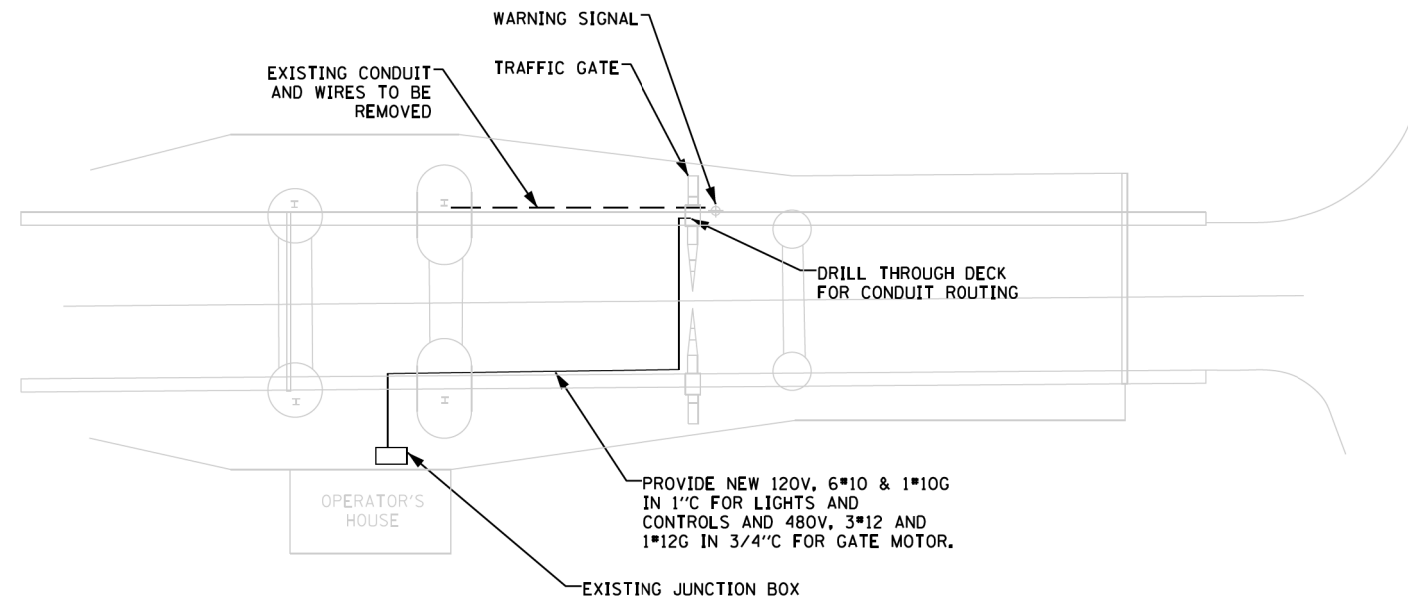

JACKSON ST. BRIDGE EAST SIDE PLAN VIEW

N.T.S

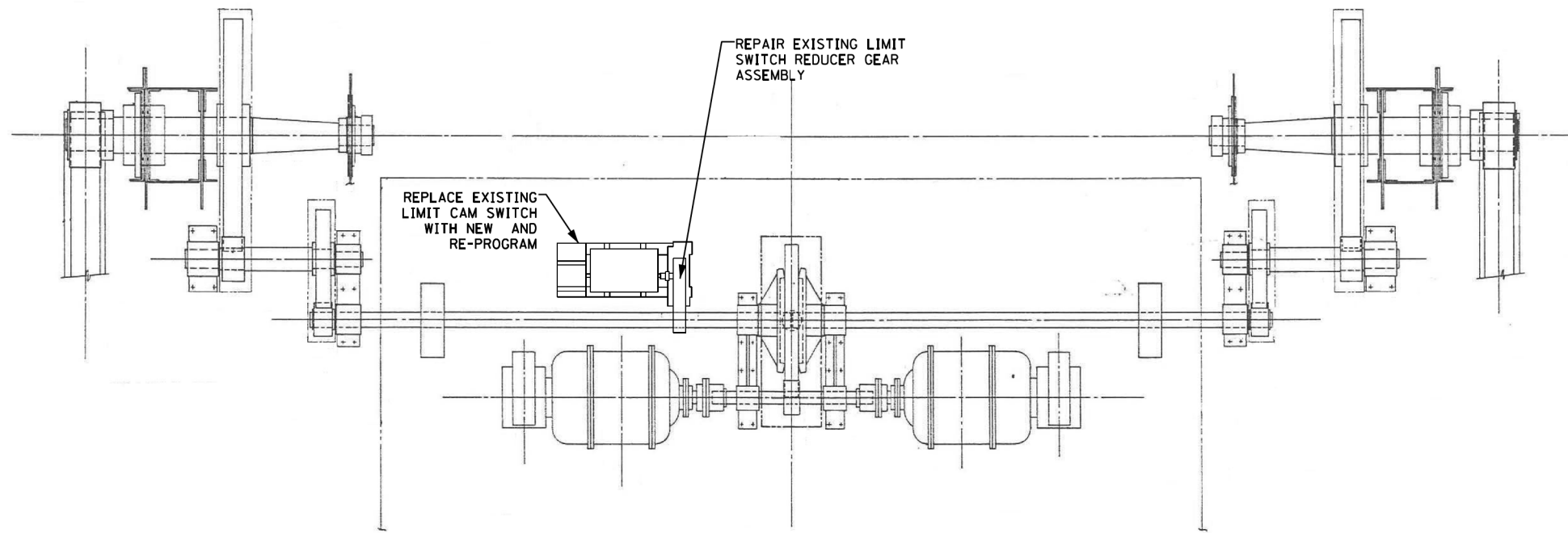

JACKSON ST. BRIDGE EAST MACHINERY ROOM PLAN

N.T.S

S:\FILES\WG\ENGR\CADD_Sheets\E2-Jackson Street Bridge.dgn 10-DEC-2014 12:07:51 PM



USER NAME = kprojepti	DESIGNED - HS	REVISED
	DRAWN - HS	REVISED
PLOT SCALE = 100.000000x1.000000	CHECKED - KGP	REVISED
PLOT DATE = 10-DEC-2014 12:01	DATE - 11/14/2014	REVISED

**STATE OF ILLINOIS
DEPARTMENT OF TRANSPORTATION**

**ELECTRICAL REPAIRS: SN 099-0239:
LOC 3: JACKSON ST BRIDGE OVER DES PLAINES RIVER RD**

SCALE: AS NOTED | SHEET NO. 2 OF 5 SHEETS | STA. TO STA.

F.A.I. RTE.	SECTION	COUNTY	TOTAL SHEETS	SHEET NO.
VAR.	2014-078BR	VAR.	24	15
			CONTRACT NO. 62A22	
ILLINOIS FED. AID PROJECT				

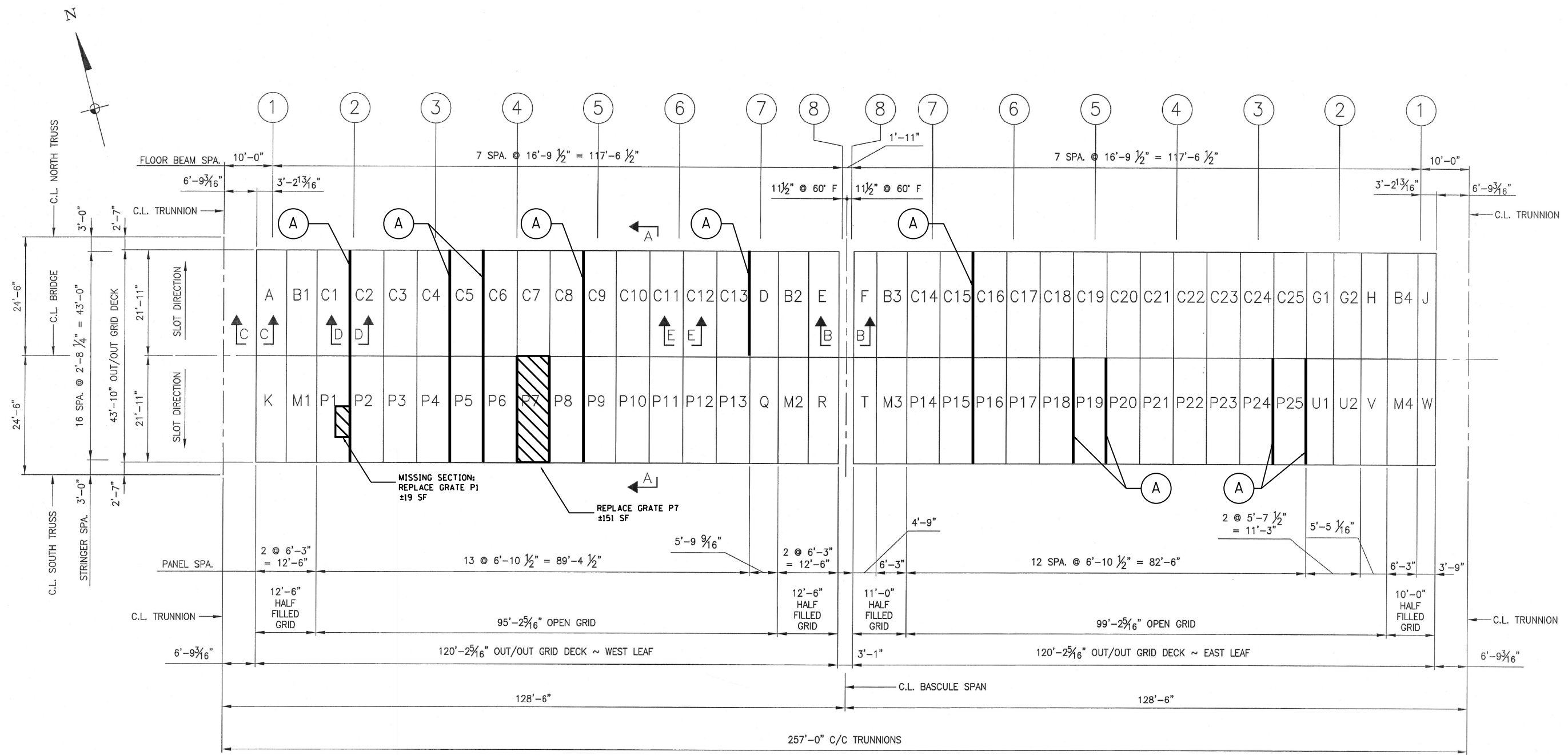

PLAN VIEW

LEGEND

(A) REPLACE BOLTS BETWEEN GRID DECK SECTIONS. (3/4)" BOLTS @ 2' C-C, 94 LB)

FILE NAME = c:\pwwork\pwwork\osbornnp\d0417055\DI0515-sht-cover.dgn	USER NAME = osbornnp	DESIGNED -	REVISED -	STATE OF ILLINOIS DEPARTMENT OF TRANSPORTATION	GRATE REPAIRS: SN 099-9901 LOC 4: RUBY ST BRIDGE (IL 53) OVER DES PLAINES RIVER RD		F.A. RTÉ.	SECTION	COUNTY	TOTAL SHEETS	SHEET NO.
	PLOT SCALE = 100.0000' / in.	CHECKED -	REVISED -				VAR	2014-078BR	WILL	24	16
Default	PLOT DATE = 12/17/2014	DATE -	REVISED -	SCALE: SHEET OF SHEETS STA. TO STA.		ILLINOIS FED. AID PROJECT					

WELD ALL INTERSECTIONS
SEE WELD PROFILES BELOW

3/16 TYP. EVERY DIAG. & SUPPL. BAR
(WELD MAY BE ON EITHER SIDE OF BAR)

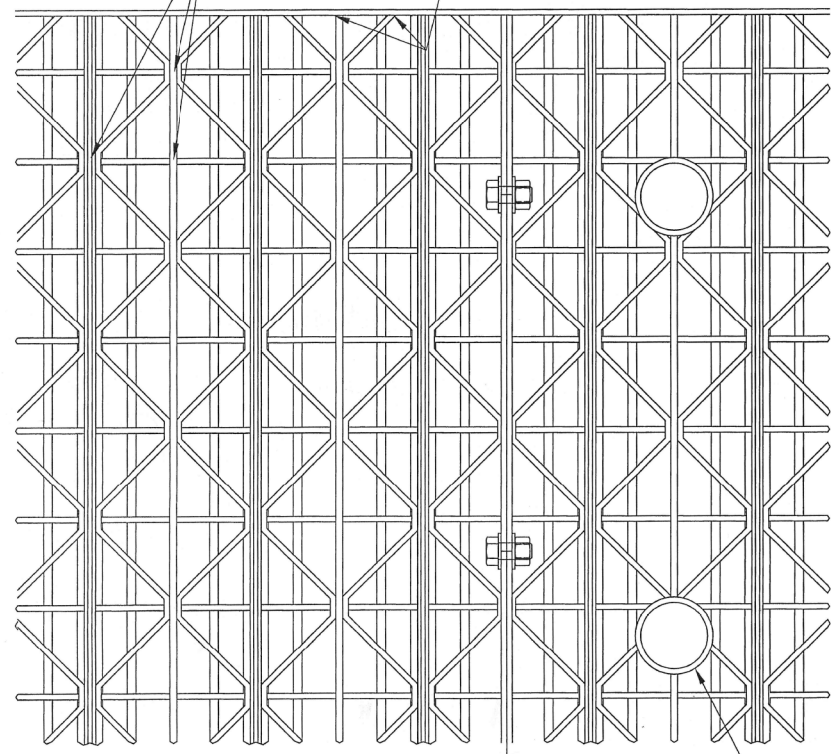

PANEL WIDTH ($\pm 1/8"$)

C.L. PANEL SPLICE
PANEL WIDTH ($\pm 1/8"$)
3" STD. PIPE SLEEVE
FOR LOCATION SEE
DRAWING LB6 (TYP)

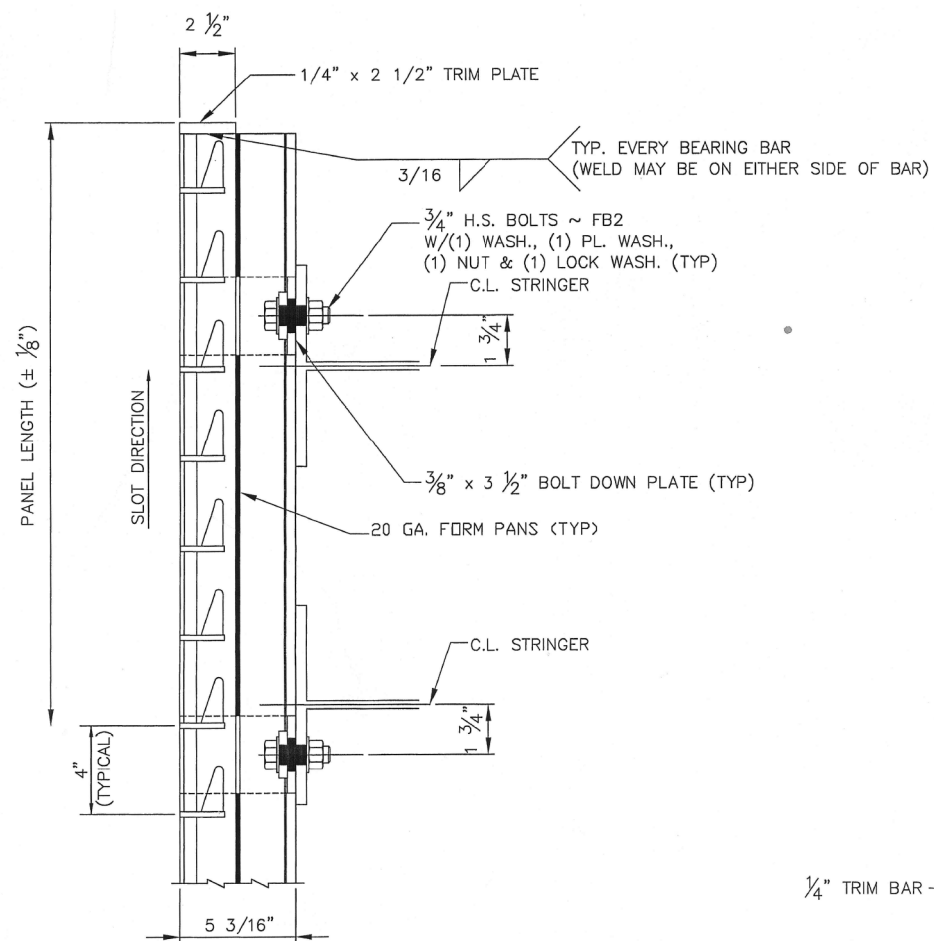

PANEL LENGTH ($\pm 1/8"$)

SLOT DIRECTION

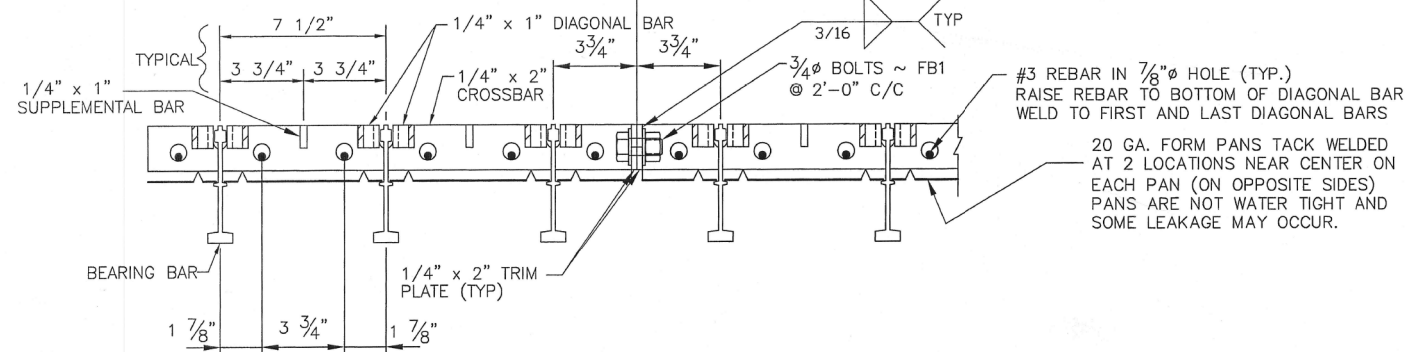

#3 REBAR IN $7/8"$ HOLE (TYP.)
RAISE REBAR TO BOTTOM OF DIAGONAL BAR
WELD TO FIRST AND LAST DIAGONAL BARS

20 GA. FORM PANS TACK WELDED
AT 2 LOCATIONS NEAR CENTER ON
EACH PAN (ON OPPOSITE SIDES)
PANS ARE NOT WATER TIGHT AND
SOME LEAKAGE MAY OCCUR.

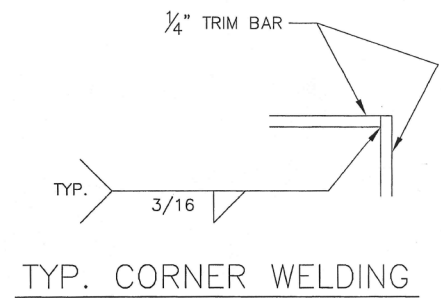

TYP. CORNER WELDING

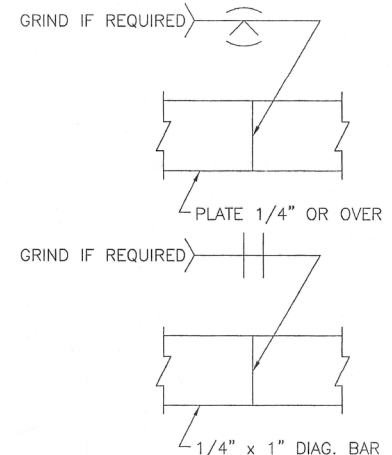

TYPICAL DETAILS 5 3/16" HALF FILLED DIAGONAL-TYPE FLOORING

(FORM PANS NOT SHOWN IN PLAN VIEW)

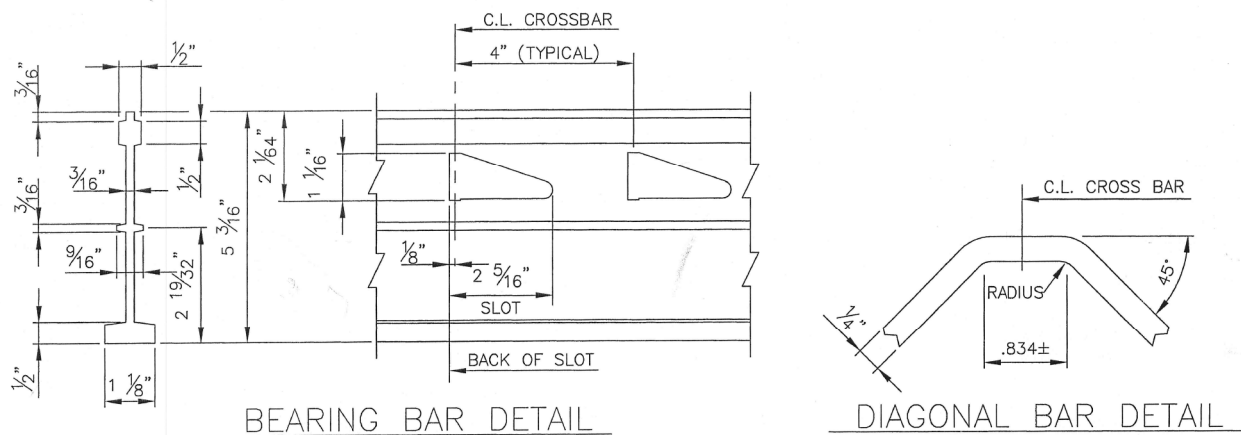

BEARING BAR DETAIL

DIAGONAL BAR DETAIL

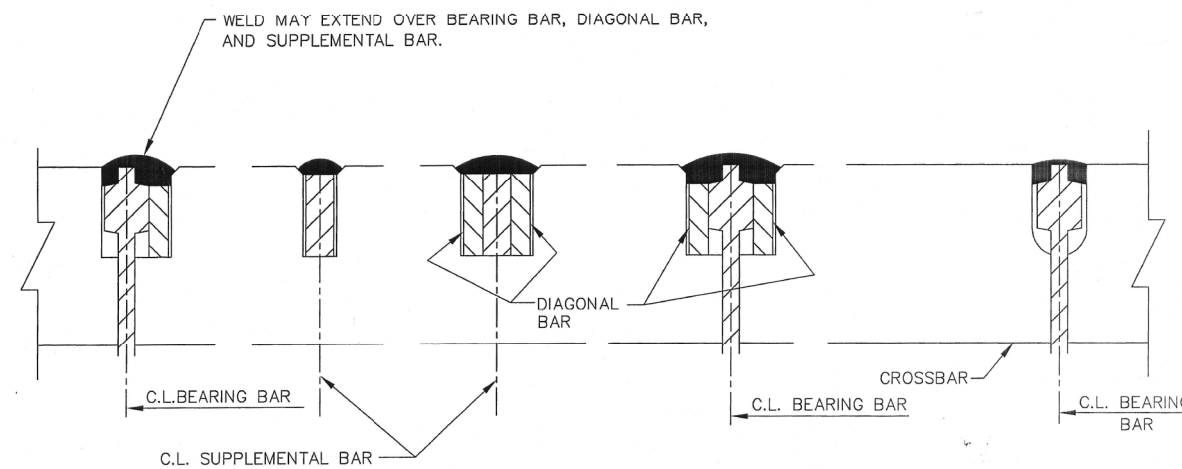

APPROXIMATE WELD PROFILES

FOR INFORMATION ONLY

FILE NAME =	USER NAME = osbornnp	DESIGNED -	REVISED -	STATE OF ILLINOIS DEPARTMENT OF TRANSPORTATION	GRATE REPAIRS: SN 099-9901			F.A. RTÉ.	SECTION	COUNTY	TOTAL SHEETS	SHEET NO.
Default	Plot Scale = 100.0000' / in.	DRAWN -	REVISED -		LOC 4: RUBY ST BRIDGE (IL 53) OVER DES PLAINES RIVER RD			VAR	2014-078BR	WILL	24	17
	PLOT DATE = 12/17/2014	CHECKED -	REVISED -		SCALE: SHEET OF SHEETS STA. TO STA.			CONTRACT NO. 62A22				
		DATE -	REVISED -		ILLINOIS FED. AID PROJECT							

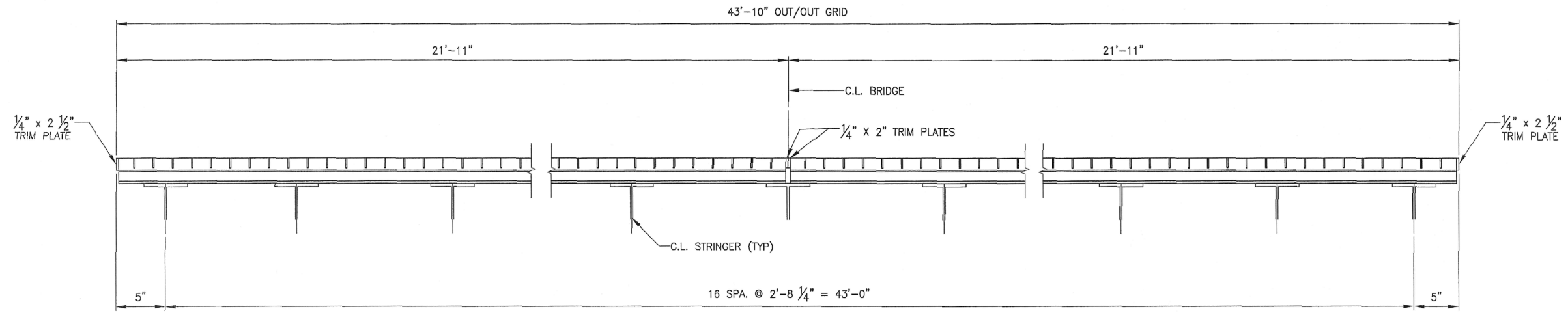

SECTION A-A

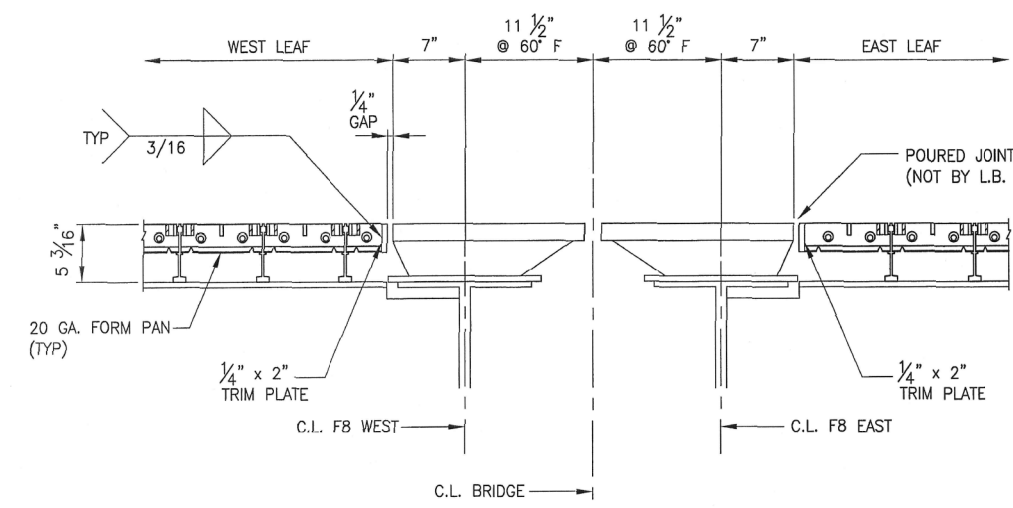

SECTION B-B

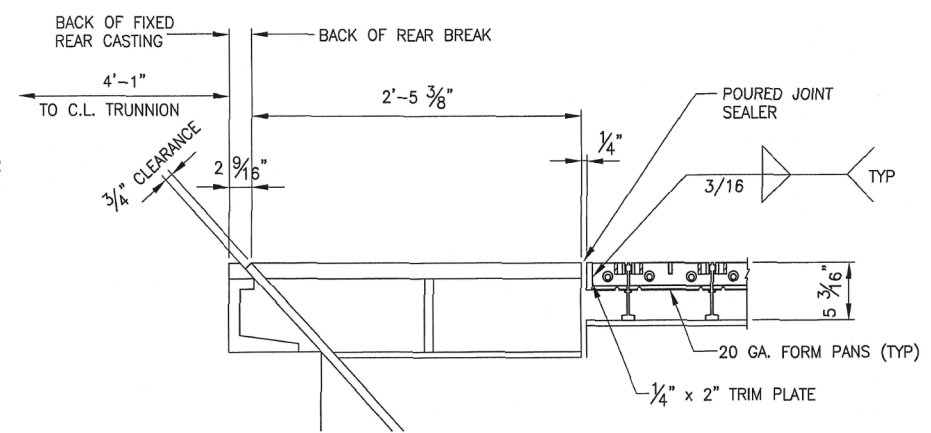

SECTION C-C

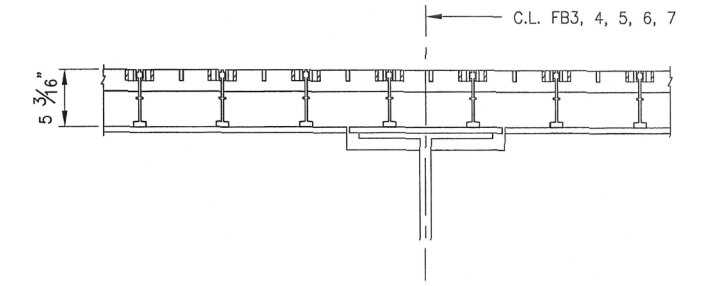

SECTION E-E

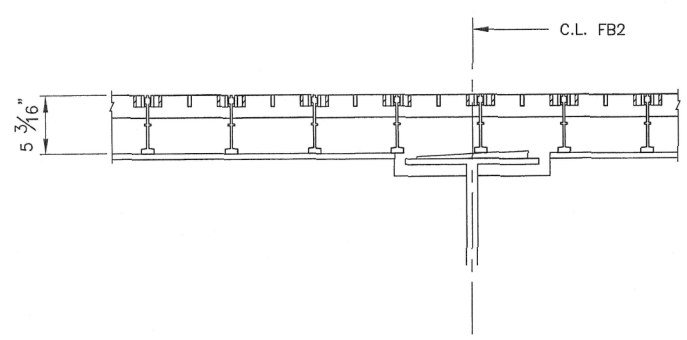

SECTION D-D

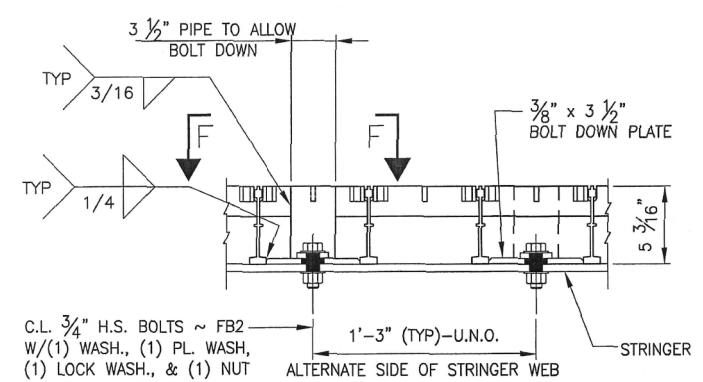

GRID BOLT DOWN ASSEMBLY
(CONCRETE NOT SHOWN FOR CLARITY)

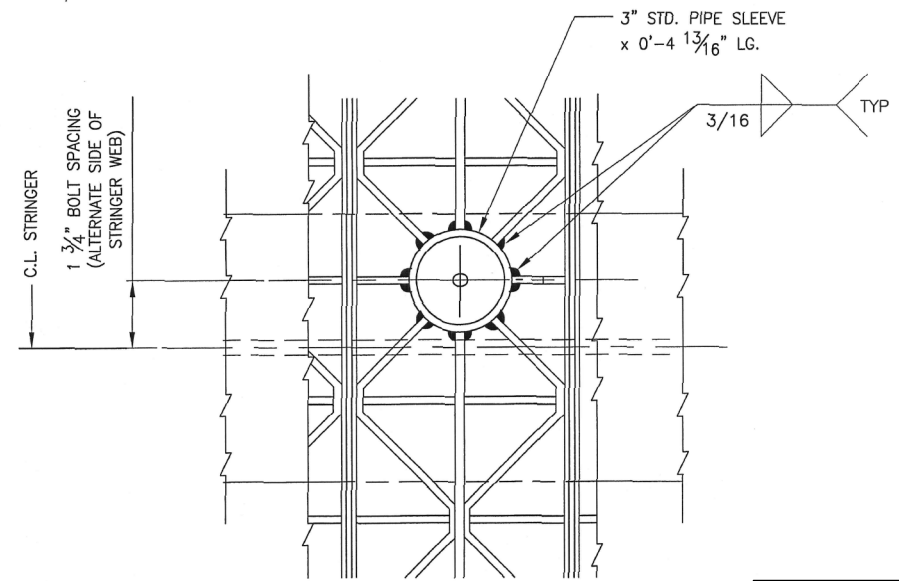

VIEW F-F

FOR INFORMATION ONLY

FILE NAME =	USER NAME = osbornenp	DESIGNED -	REVISED -	STATE OF ILLINOIS DEPARTMENT OF TRANSPORTATION	GRATE REPAIRS: SN 099-9901			F.A. RTE.	SECTION	COUNTY	TOTAL SHEETS	SHEET NO.
Default	Plot Scale = 100.0000' / in.	DRAWN -	REVISED -		LOC 4: RUBY ST BRIDGE (IL 53) OVER DES PLAINES RIVER RD			VAR	2014-078BR	WILL	24	18
	PLOT DATE = 12/17/2014	CHECKED -	REVISED -		SCALE: SHEET OF SHEETS STA. TO STA.			CONTRACT NO. 62A22				
		DATE -	REVISED -		ILLINOIS FED. AID PROJECT							

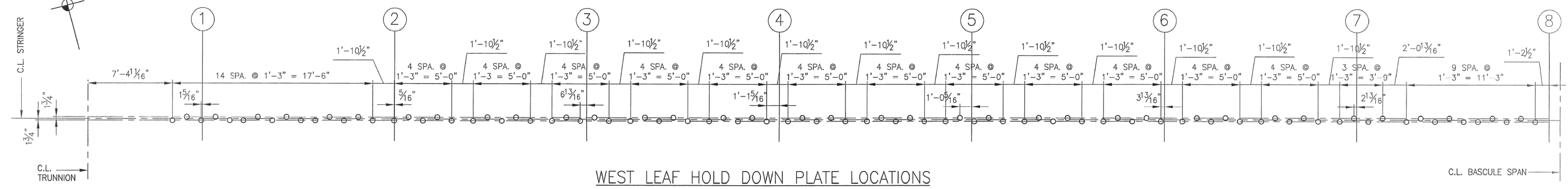

WEST LEAF HOLD DOWN PLATE LOCATIONS

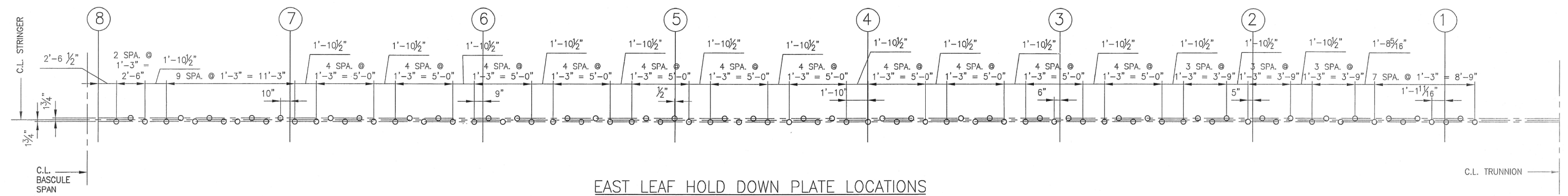

EAST LEAF HOLD DOWN PLATE LOCATIONS

NOTE:
 CONTRACTOR TO FIELD VERIFY COMPATIBILITY BETWEEN
 EXISTING CONDITIONS AND PROPOSED TIE DOWN LOCATIONS
 ASSOCIATED WITH GRID CONFIGURATIONS.

FOR INFORMATION ONLY

FILE NAME =	USER NAME = osbornnp	DESIGNED -	REVISED -	STATE OF ILLINOIS DEPARTMENT OF TRANSPORTATION	GRATE REPAIRS: SN 099-9901 LOC 4: RUBY ST BRIDGE (IL 53) OVER DES PLAINES RIVER RD			F.A. RTE.	SECTION	COUNTY	TOTAL SHEETS	SHEET NO.				
Default	Plot Scale = 100.0000' / in.	DRAWN -	REVISED -		SCALE:	SHEET	OF	SHEETS	STA.	TO	STA.	VAR	2014-078BR	WILL	24	19
	PLOT DATE = 12/17/2014	CHECKED -	REVISED -										CONTRACT NO. 62A22			
		DATE -	REVISED -										ILLINOIS FED. AID PROJECT			



RUBY STREET PLAN VIEW
N.T.S



REPLACE COMED METER BOX WITH NEW. SERVICE RATED. COORDINATE WITH COMED FOR INTERRUPTION OF SERVICE, DISCONNECTING AND RECONNECTING SERVICE AND METER.

RUBY STREET METER BOX
N.T.S

SCHEDULE OF QUANTITIES

ITEM	UNIT	RUBY BRIDGE
REMOVE AND REPLACE EXISTING ELECTRIC SERVICE METER ENCLOSURE	EACH	1

S:\FILES\WG\EN\DRN\CADD_Sheets\E3-Ruby St Bridge.dgn 09-DEC-2014 17:08:11MS



USER NAME = kprojepti	DESIGNED - HS	REVISED
	DRAWN - HS	REVISED
PLOT SCALE = 100.000000x1.000000	CHECKED - KGP	REVISED
PLOT DATE = 09-DEC-2014 17:01	DATE - 11/14/2014	REVISED

**STATE OF ILLINOIS
DEPARTMENT OF TRANSPORTATION**

**ELETRICAL REPAIRS: SN 099-9901
LOC 4: RUBY ST BRIDGE (IL 53) OVER DES PLAINES RIVER RD**
SCALE: AS NOTED SHEET NO. 3 OF 5 SHEETS STA. TO STA.

F.A.I. RTE.	SECTION	COUNTY	TOTAL SHEETS	SHEET NO.
VAR.	2014-078BR	VAR.	24	20
			CONTRACT NO. 62A22	
ILLINOIS FED. AID PROJECT				

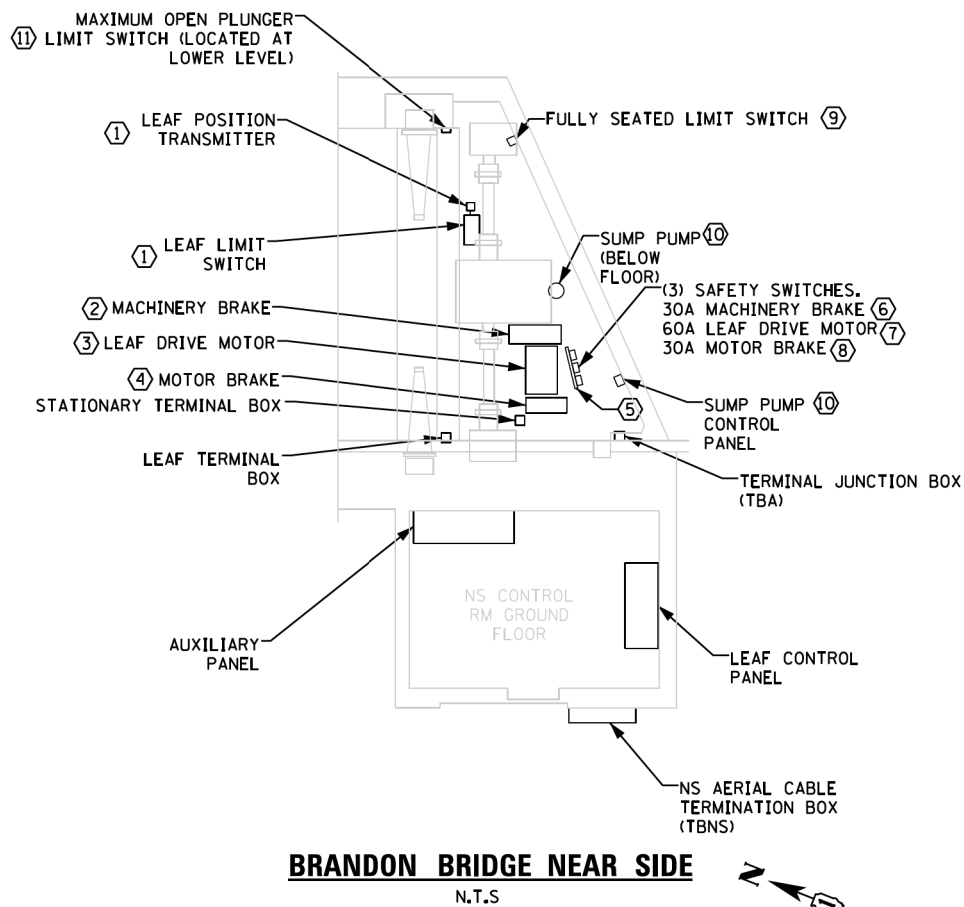

BRANDON BRIDGE NEAR SIDE

N.T.S

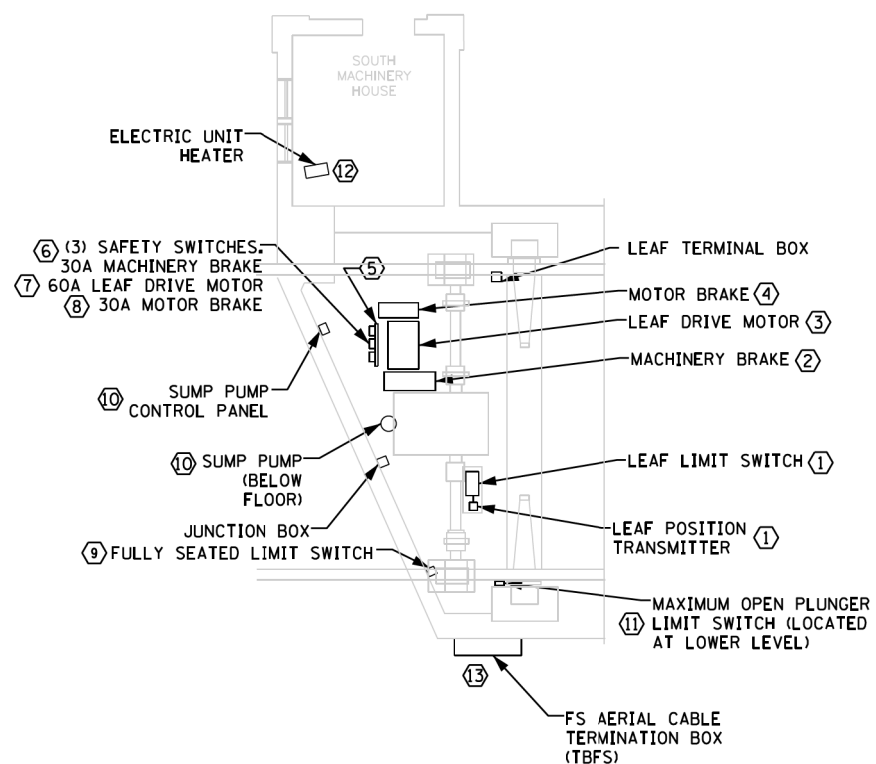

BRANDON BRIDGE FAR SIDE

N.T.S

SCHEDULE OF QUANTITIES

ITEM	UNIT	099-9903 BRANDON RD BRIDGE
CONDUIT ATTACHED TO STRUCTURE, 3/4" DIA., PVC COATED GALVANIZED STEEL	FOOT	324
CONDUIT ATTACHED TO STRUCTURE, 2" DIA., PVC COATED GALVANIZED STEEL	FOOT	52
JUNCTION BOX, STAINLESS STEEL, ATTACHED TO STRUCTURE, 42" X 36" X 12"	EACH	1
ELECTRIC CABLE IN CONDUIT, 600V (XLP-TYPE USE) 1/C NO. 12	FOOT	1152
ELECTRIC CABLE IN CONDUIT, 600V (XLP-TYPE USE) 1/C NO. 14	FOOT	916
ELECTRIC CABLE IN CONDUIT, 600V (XLP-TYPE USE) 1/C NO. 2	FOOT	364
REMOVE ELECTRIC CABLE FROM CONDUIT	FOOT	815
REMOVE CONDUIT ATTACHED TO STRUCTURE	FOOT	376
DISCONNECT SWITCH 3-POLE, 600V 30AMP	EACH	4
REMOVE EXISTING JUNCTION BOX	EACH	1
REMOVE AND REPLACE METAL CHANNEL SUPPORT	FOOT	40
DISCONNECT SWITCH 3-POLE, 600V 60AMP	EACH	2
REMOVE AND REPLACE FULLY SEATED LIMIT SWITCH	EACH	2
REMOVE AND REPLACE MAXIMUM OPEN LIMIT SWITCH	EACH	2
REMOVE AND REPLACE EXISTING ELECTRIC WALL HEATER	EACH	1

KEY NOTES

- 1) CONTRACTOR SHALL RE-PROGRAM ROTATING CAM LIMIT SWITCH. COORDINATE WITH BRIDGE OPERATOR.
- 2) REMOVE EXISTING CONDUIT AND WIRES FROM MACHINERY BREAK TO SAFETY SWITCH. PROVIDE 5*12, 1*12G, AND 4*14 IN 3/4" PVC COATED RGS CONDUIT.
- 3) REMOVE EXISTING CONDUIT AND WIRES FROM LEAF DRIVE MOTOR TO SAFETY SWITCH. PROVIDE 6*2, 1*2G, AND 4*12 IN 2" PVC COATED RGS CONDUIT.
- 4) REMOVE EXISTING CONDUIT AND WIRES FROM MOTOR BRAKE TO SAFETY SWITCH. PROVIDE 5*12, 1*12G, AND 4*14 IN 3/4" PVC COATED RGS CONDUIT.
- 5) REMOVE EXISTING UNISTRAT MOUNTING. PROVIDE NEW UNISTRAT MOUNTING FOR SAFETY SWITCHES.
- 6) REMOVE MACHINERY BRAKE SAFETY SWITCH. PROVIDE NEW 30A, 3PH, 3P, NEMA-3R SAFETY SWITCH. REMOVE EXISTING CONDUIT AND WIRES FROM MACHINERY BRAKE SAFETY SWITCH TO TBA. PROVIDE 5*12, 1*12G, AND 4*14 IN 3/4" PVC COATED RGS CONDUIT.
- 7) REMOVE LEAF DRIVE MOTOR SAFETY SWITCH. PROVIDE NEW 60A, 3PH, 3P, NEMA-3R SAFETY SWITCH. REMOVE EXISTING CONDUIT AND WIRES FROM LEAF DRIVE MOTOR SAFETY SWITCH TO TBA. PROVIDE 6*2, 1*2G, AND 4*12 IN 2" PVC COATED RGS CONDUIT.
- 8) REMOVE MOTOR BRAKE SAFETY SWITCH. PROVIDE NEW 30A, 3PH, 3P, NEMA-3R SAFETY SWITCH. REMOVE EXISTING CONDUIT AND WIRES FROM MOTOR BRAKE SAFETY SWITCH TO TBA. PROVIDE 5*12, 1*12G, AND 4*14 IN 3/4" PVC COATED RGS CONDUIT.
- 9) REPLACE FULLY SEATED LIMIT SWITCH WITH NEW.
- 10) REMOVE POWER AND SENSOR CONDUIT AND WIRE FROM SUMP PUMP TO SUMP PUMP CONTROL PANEL. CORE DRILL THE OPENING, PROVIDE 3*12 AND 1*12G IN 3/4" PVC COATED RGS CONDUIT FOR POWER AND 4*14 IN 3/4" PVC COATED RGS CONDUIT FOR SENSOR FROM SUMP PUMP TO SUMP PUMP CONTROL PANEL. SEAL THE OPENING.
- 11) REMOVE MAXIMUM OPEN PLUNGER LIMIT SWITCH AND ASSOCIATED CONDUIT AND WIRE UP TO WHERE CONDUIT RUNS ENCASED IN CONCRETE. PROVIDE NEW MAXIMUM OPEN PLUNGER LIMIT SWITCH. PROVIDE NEMA-3R JUNCTION BOX WHERE CONDUIT RUNS ENCASED IN CONCRETE. PROVIDE 2*14 AND 1*14 IN 3/4" PVC COATED RGS CONDUIT FROM SWITCH TO THE JUNCTION BOX.

KEY NOTES

- 1) CONTRACTOR SHALL RE-PROGRAM ROTATING CAM LIMIT SWITCH. COORDINATE WITH BRIDGE OPERATOR.
- 2) REMOVE EXISTING CONDUIT AND WIRES FROM MACHINERY BREAK TO SAFETY SWITCH. PROVIDE 9*10, 1*10G IN 1" PVC COATED RGS CONDUIT.
- 3) REMOVE EXISTING CONDUIT AND WIRES FROM LEAF DRIVE MOTOR TO SAFETY SWITCH. PROVIDE 6*2, 1*2G, AND 4*10 IN 2" PVC COATED RGS CONDUIT.
- 4) REMOVE EXISTING CONDUIT AND WIRES FROM MOTOR BRAKE TO SAFETY SWITCH. PROVIDE 9*10, 1*10G IN 1" PVC COATED RGS CONDUIT.
- 5) REMOVE EXISTING METAL CHANNEL MOUNTING SUPPORT. PROVIDE NEW METAL CHANNEL MOUNTING SUPPORT FOR SAFETY SWITCHES.
- 6) REMOVE MACHINERY BRAKE SAFETY SWITCH. PROVIDE NEW 30A, 3PH, 3P, NEMA-3R SAFETY SWITCH. REMOVE EXISTING CONDUIT AND WIRES FROM MACHINERY BRAKE SAFETY SWITCH TO TBFS. PROVIDE 9*10, 1*10G IN 1" PVC COATED RGS CONDUIT.
- 7) REMOVE LEAF DRIVE MOTOR SAFETY SWITCH. PROVIDE NEW 60A, 3PH, 3P, NEMA-3R SAFETY SWITCH. REMOVE EXISTING CONDUIT AND WIRES FROM LEAF DRIVE MOTOR SAFETY SWITCH TO TBFS. PROVIDE 6*2, 1*2G, AND 4*12 IN 2" PVC COATED RGS CONDUIT.
- 8) REMOVE MOTOR BRAKE SAFETY SWITCH. PROVIDE NEW 30A, 3PH, 3P, NEMA-3R SAFETY SWITCH. REMOVE EXISTING CONDUIT AND WIRES FROM MOTOR BRAKE SAFETY SWITCH TO TBFS. PROVIDE 9*10, 1*10G IN 1" PVC COATED RGS CONDUIT.
- 9) REPLACE FULLY SEATED LIMIT SWITCH WITH NEW.
- 10) REMOVE POWER AND SENSOR CONDUIT AND WIRE FROM SUMP PUMP TO SUMP PUMP CONTROL PANEL. CORE DRILL THE OPENING, PROVIDE 3*12 AND 1*12G IN 3/4" PVC COATED RGS CONDUIT FOR POWER AND 4*14 IN 3/4" PVC COATED RGS CONDUIT FOR SENSOR FROM SUMP PUMP TO SUMP PUMP CONTROL PANEL. SEAL THE OPENING.
- 11) REMOVE MAXIMUM OPEN PLUNGER LIMIT SWITCH AND ASSOCIATED CONDUIT AND WIRE UP TO WHERE CONDUIT RUNS ENCASED IN CONCRETE. PROVIDE NEW MAXIMUM OPEN PLUNGER LIMIT SWITCH. PROVIDE NEMA-3R JUNCTION BOX WHERE CONDUIT RUNS ENCASED IN CONCRETE. PROVIDE 2*14 AND 1*14 IN 3/4" PVC COATED RGS CONDUIT FROM SWITCH TO THE JUNCTION BOX.
- 12) REPLACE ELECTRIC UNIT HEATER WITH NEW. MATCH EXISTING UNIT.
- 13) REPLACE FS AERIAL CABLE TERMINATION BOX (TBFS) WITH NEW.

I:\FILES\WG_P\DRN\CADD_Sheets\E1-BrandonRoadBridge.dgn 09-DEC-2014 12:08:15PM



USER NAME = kprojapati	DESIGNED - HS	REVISED
PLOT SCALE = 100.000000:1.000000	DRAWN - HS	REVISED
PLOT DATE = 09-DEC-2014 17:01	CHECKED - KGP	REVISED
	DATE - 11/14/2014	REVISED

**STATE OF ILLINOIS
DEPARTMENT OF TRANSPORTATION**

**ELECTRICAL REPAIRS
LOC 5: BRANDON RD, SN 099-9903**

SCALE: AS NOTED SHEET NO. 1 OF 5 SHEETS STA. TO STA.

F.A.I. RTE.	SECTION	COUNTY	TOTAL SHEETS	SHEET NO.
VAR.	2014-0788R	VAR.	24	21
			CONTRACT NO. 62A22	
ILLINOIS FED. AID PROJECT				

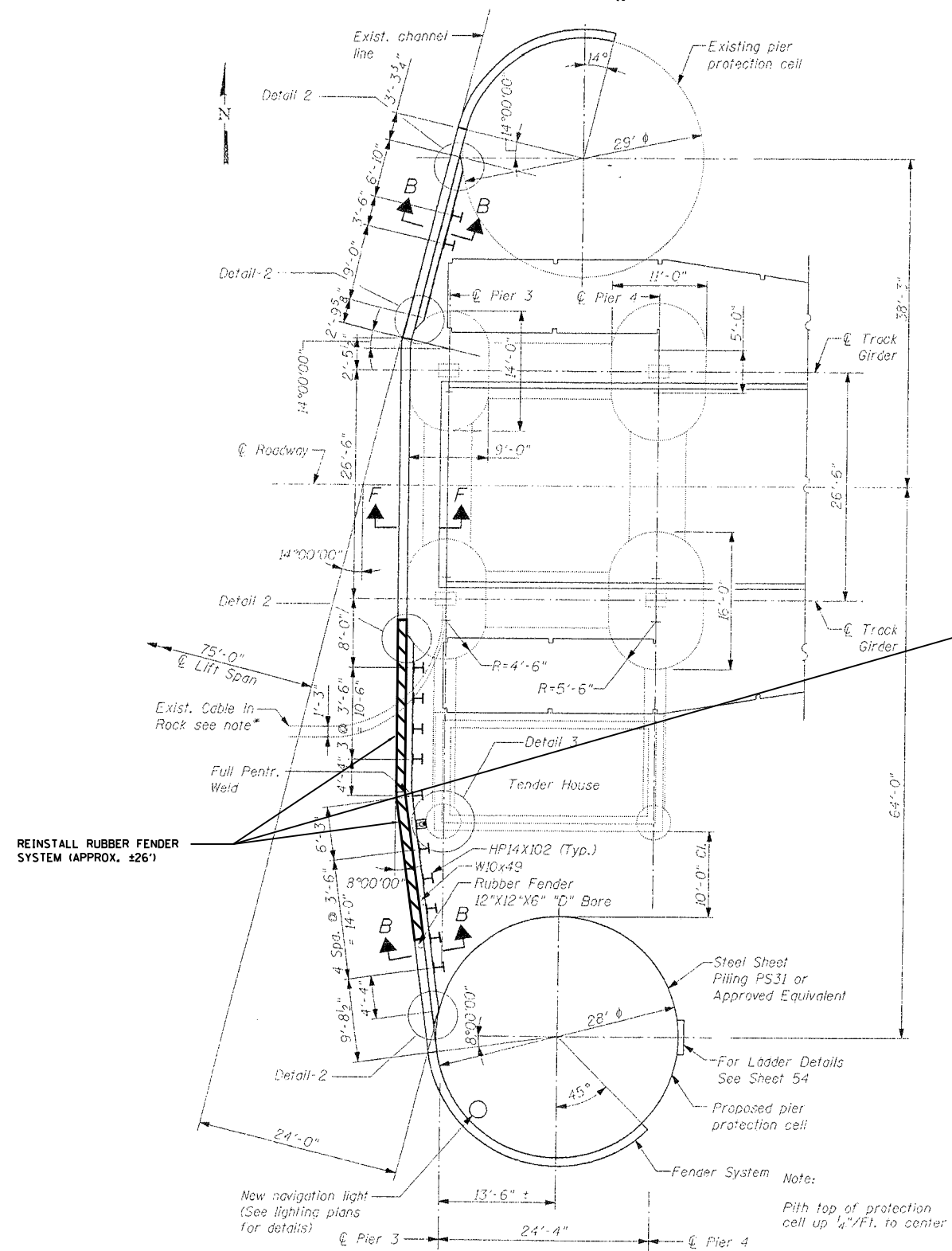

PIER PROTECTION CELL & FENDER SYSTEM PARTIAL PLAN

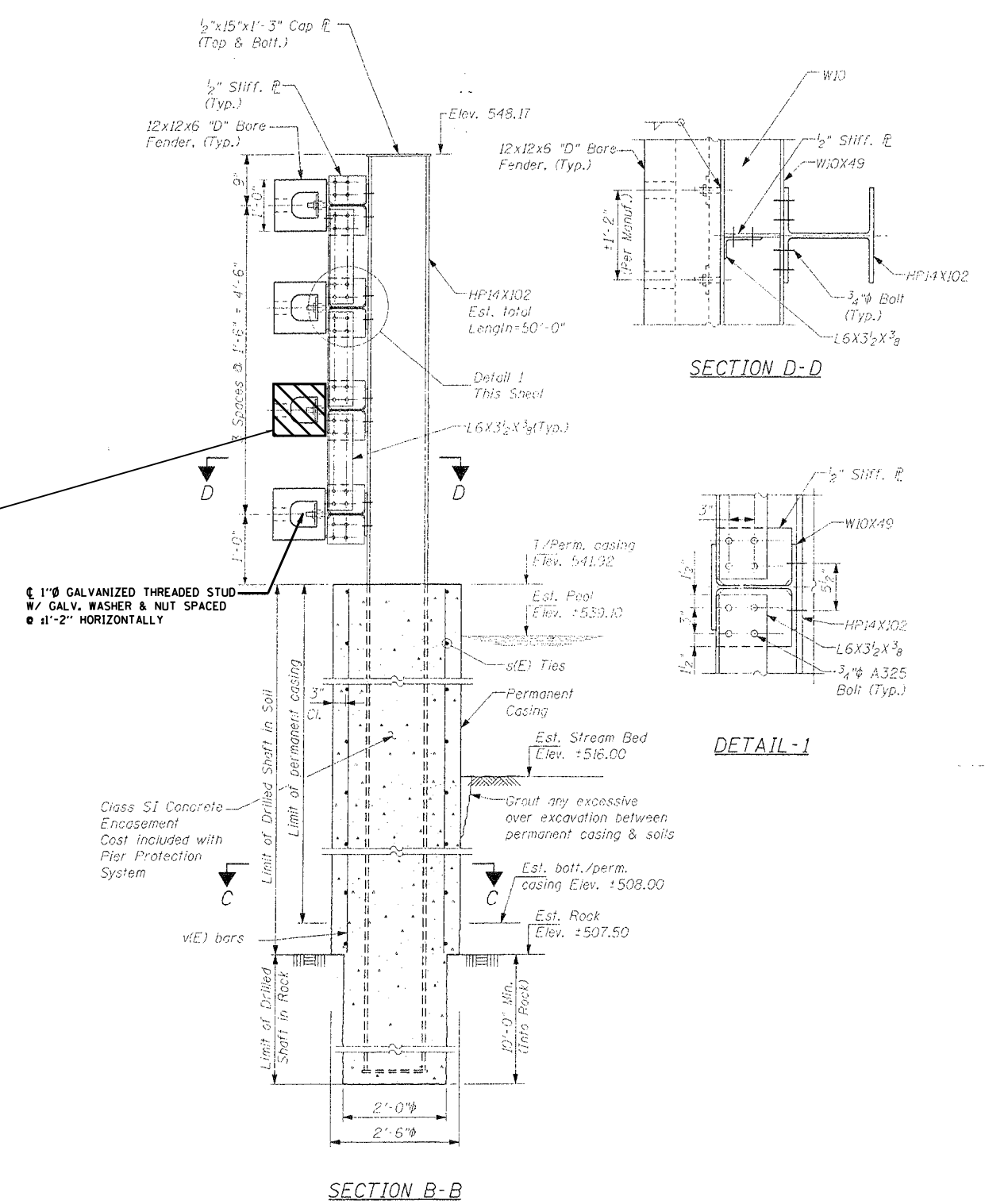

SECTION B-B

SECTION D-D

DETAIL-1

SCHEDULE OF QUANTITIES

ITEM	UNIT	TOTAL
REINSTALL RUBBER FENDER SYSTEM	L SUM	0.3

FILE NAME =	USER NAME = osbornnp	DESIGNED -	REVISED -
et:\pwork\work\pwork\osbornnp\d0417055\DI0515-sht-cover.dgn		DRAWN -	REVISED -
Default	PLOT DATE = 12/17/2014	CHECKED -	REVISED -
		DATE -	REVISED -

STATE OF ILLINOIS
DEPARTMENT OF TRANSPORTATION

FENDER REPAIRS
LOC 6: US 6/US 52 (McDONOUGH ST), SN 099-9904

SCALE: SHEET OF SHEETS STA. TO STA.

F.A. RTE.	SECTION	COUNTY	TOTAL SHEETS	SHEET NO.
VAR	2014-078BR	WILL	24	22
CONTRACT NO. 62A22				
ILLINOIS FED. AID PROJECT				

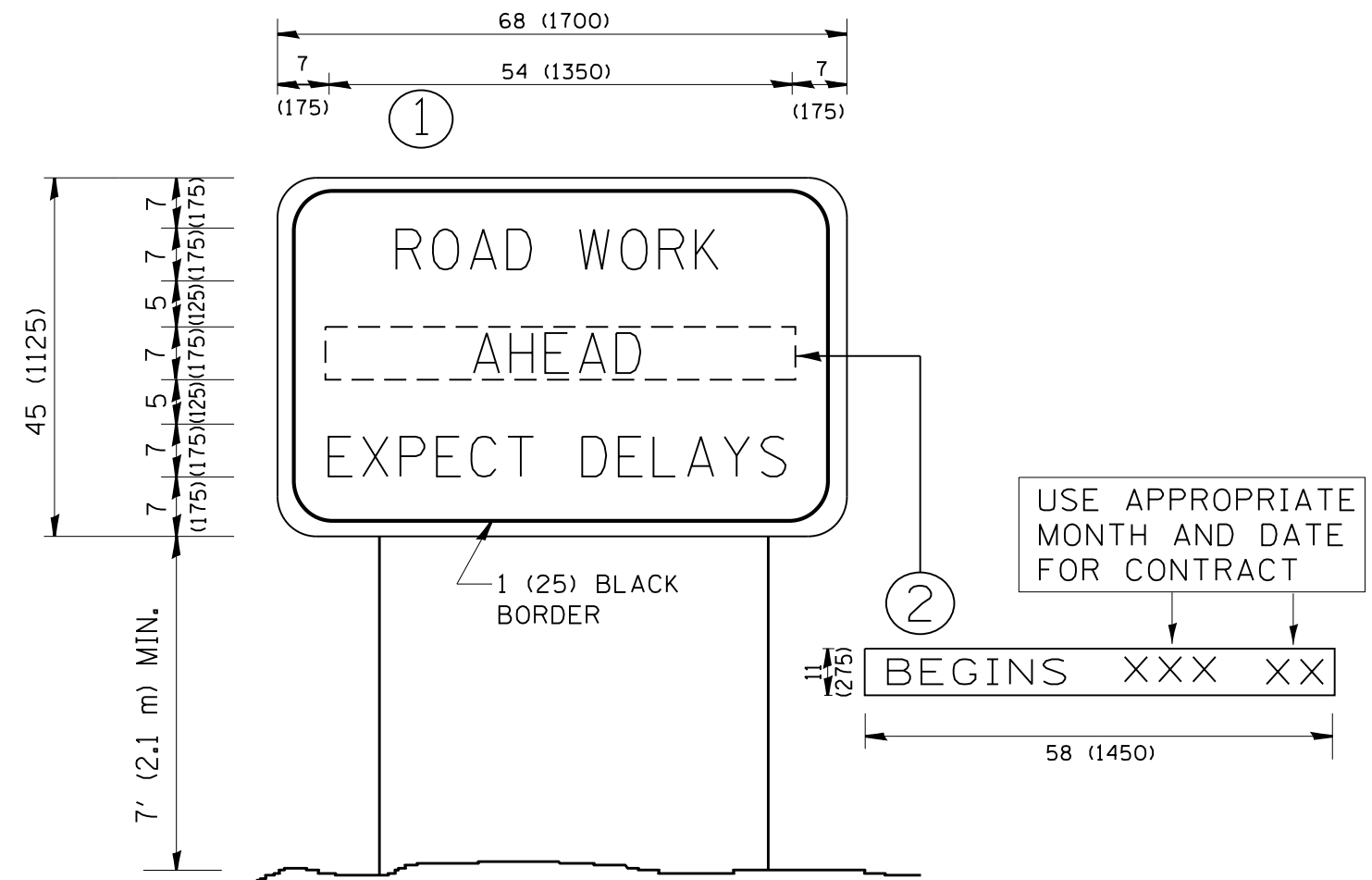

NOTES:

1. USE BLACK LETTERING ON ORANGE BACKGROUND.
2. ERECT SIGNS IN ADVANCE OF THE LOCATION FOR THE "ROAD CONSTRUCTION AHEAD" SIGN AT LOCATIONS AS DIRECTED BY THE ENGINEER.
3. ERECT SIGN ① WITH INSTALLED PANEL ② ONE WEEK PRIOR TO THE START OF CONSTRUCTION.
4. REMOVE PANEL ② SOON AFTER THE START OF CONSTRUCTION.
5. SEE SPECIAL PROVISION FOR "TEMPORARY INFORMATION SIGNING" FOR ADDITIONAL INFORMATION.
6. ONE SIGN ASSEMBLY EQUALS 25.70 SQ. FT. (2.3 SQ. M.)
7. SHALL BE PAID FOR AS TEMPORARY INFORMATION SIGNING.

ALL DIMENSIONS ARE IN INCHES (MILLIMETERS) UNLESS OTHERWISE SHOWN.

FILE NAME =	USER NAME = osbornnp	DESIGNED -	REVISED - R. MIRS 09-15-97
ct:\pw_work\p1dot\osbornnp\d0417055\DI	0515-sht-cover.dgn	DRAWN -	REVISED - R. MIRS 12-11-97
Default	PLOT SCALE = 100.0000' / in.	CHECKED -	REVISED - T. RAMMACHER 02-02-99
	PLOT DATE = 12/17/2014	DATE -	REVISED - C. JUCIUS 01-31-07

**STATE OF ILLINOIS
DEPARTMENT OF TRANSPORTATION**

**ARTERIAL ROAD
INFORMATION SIGN**

SCALE: NONE SHEET 1 OF 1 SHEETS STA. TO STA.

F.A. RTÉ.	SECTION	COUNTY	TOTAL SHEETS	SHEET NO.
	TC-22		24	23
			CONTRACT NO.	
ILLINOIS FED. AID PROJECT				

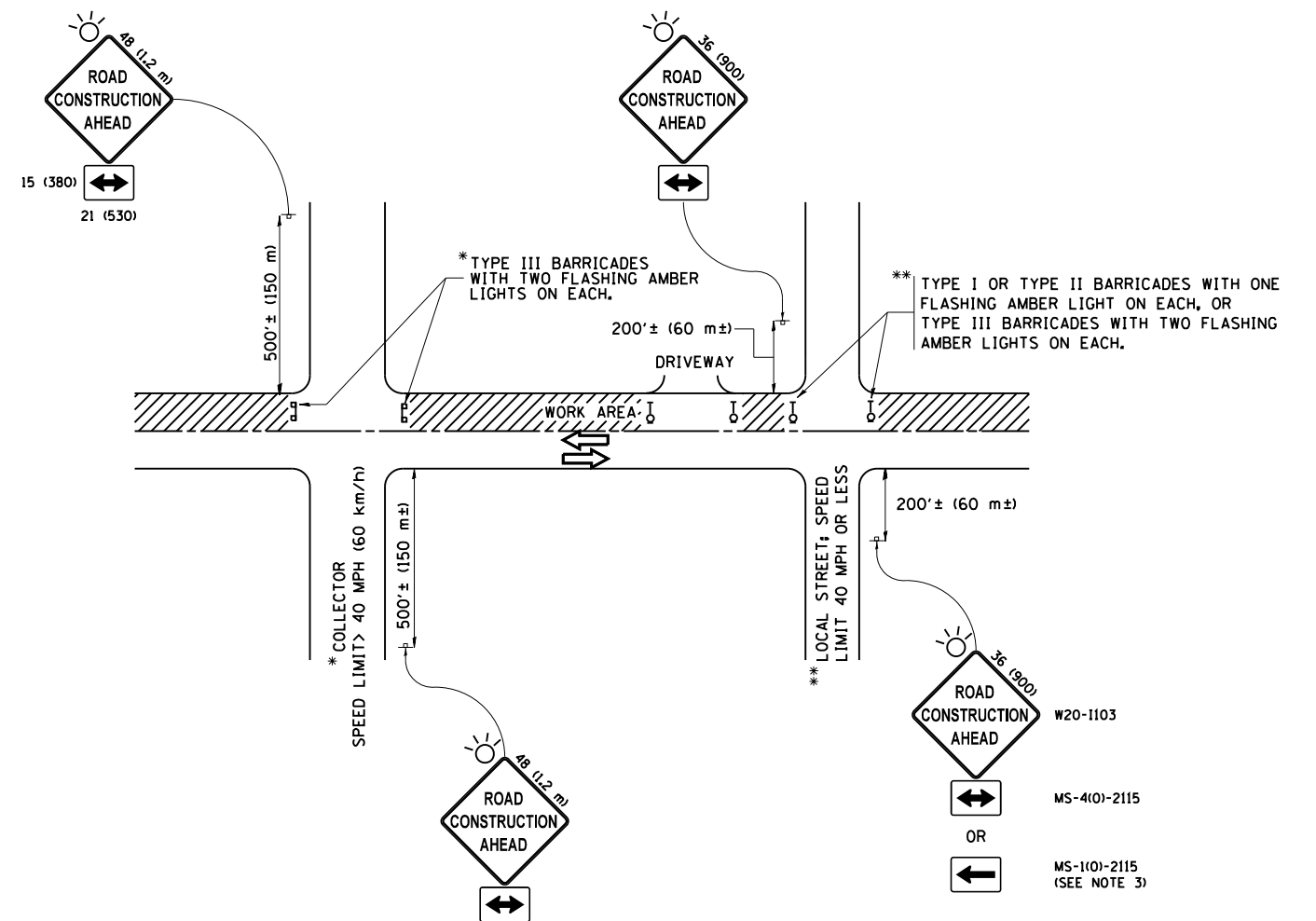

TRAFFIC CONTROL AND PROTECTION FOR SIDE ROADS, INTERSECTIONS, AND DRIVEWAYS

NOTES:

A. FOR NO LANE RESTRICTION ON THE SIDE ROAD OR DRIVEWAYS

1. SIDE ROAD WITH A SPEED LIMIT OF 40 MPH (60 km/h) OR LESS AS SHOWN ON THE DRAWING AND AS DIRECTED BY THE ENGINEER:
 - a) ONE ROAD CONSTRUCTION AHEAD SIGN 36 x 36 (900x900) WITH A FLASHER ON IT APPROXIMATELY 200' (60 m) IN ADVANCE OF THE MAIN ROUTE.
 - b) THE CLOSED PORTION OF THE MAIN ROUTE SHALL BE PROTECTED BY BLOCKING WITH TYPE I, TYPE II OR TYPE III BARRICADES, 1/3 OF THE CROSS SECTION OF THE CLOSED PORTION.
2. SIDE ROAD WITH A SPEED LIMIT GREATER THAN 40 MPH (60 km/h) AS SHOWN ON THE DRAWING AND AS DIRECTED BY THE ENGINEER:
 - a) ONE ROAD CONSTRUCTION AHEAD SIGN 48 x 48 (1,2 m x 1,2 m) WITH A FLASHER MOUNTED ON IT APPROXIMATELY 500' (150 m) IN ADVANCE OF THE MAIN ROUTE.
 - b) THE CLOSED PORTION OF THE MAIN ROUTE SHALL BE PROTECTED BY BLOCKING WITH TYPE III BARRICADES, 1/2 OF THE CROSS SECTION OF THE CLOSED PORTION.
3. WHEN THE SIDE ROAD LIES BETWEEN THE BEGINNING OF THE MAINLINE SIGNING AND THE WORK ZONE, A SINGLE HEADED ARROW (M6-1) SHALL BE USED IN LIEU OF THE DOUBLE HEADED ARROW (M6-4).

B. FOR A LANE CLOSURE ON A SIDE ROAD OR DRIVEWAY:

- USE APPLICABLE PORTIONS OF THE TYPICAL APPLICATION OF TRAFFIC CONTROL DEVICES (STD. 701501, STD. 701606 OR THE APPROPRIATE STANDARD). THE SPACING OF SIGNS AND BARRICADES SHALL BE ADJUSTED FOR FIELD CONDITIONS AS DIRECTED BY THE ENGINEER. THE DIRECTIONAL ARROW SHALL BE COVERED OR REMOVED WHEN NO LONGER CONSISTENT WITH THE SIDE ROAD LANE CLOSURE.
- C. ADVANCE WARNING SIGNS ARE TO BE OMITTED ON DRIVEWAY UNLESS OTHERWISE NOTED.
 - D. THE TRAFFIC CONTROL AND PROTECTION FOR SIDE ROADS, INTERSECTIONS, AND DRIVEWAYS SHALL BE INCIDENTAL TO THE COST OF SPECIFIED TRAFFIC CONTROL STANDARDS OR ITEMS.

All dimensions are in millimeters (inches) unless otherwise shown.

FILE NAME =	USER NAME = osbornnp	DESIGNED - L.H.A.	REVISED - J.OBERLE 10-18-95
c:\pwwork\pwwork\osbornnp\d0417055\DI	0515-sht-cover.dgn	DRAWN -	REVISED - A. HOUSEH 10-15-96
Default	PLOT SCALE = 100.0000' / in.	CHECKED -	REVISED - T. RAMMACHER 01-06-00
	PLOT DATE = 12/17/2014	DATE - 06-89	REVISED - A. SCHUETZE 07-01-13

STATE OF ILLINOIS
DEPARTMENT OF TRANSPORTATION

TRAFFIC CONTROL AND PROTECTION FOR
SIDE ROADS, INTERSECTIONS, AND DRIVEWAYS

SCALE: NONE SHEET 1 OF 1 SHEETS STA. TO STA.

F.A. RTE.	SECTION	COUNTY	TOTAL SHEETS	SHEET NO.
			24	24
TC-10			CONTRACT NO.	
ILLINOIS FED. AID PROJECT				