

STATE OF ILLINOIS
DEPARTMENT OF TRANSPORTATION

ROUTE NO. F.A.P. 368	SUBSECTION VB-R-1	COUNTY Cook	TOTAL SHEETS 47	SHEET NO. 25	SHEET NO. 16 28 SHEETS
FED. ROAD DIST. NO. 7		ILLINOIS		FED. AID PROJECT	

Contract # 60C11

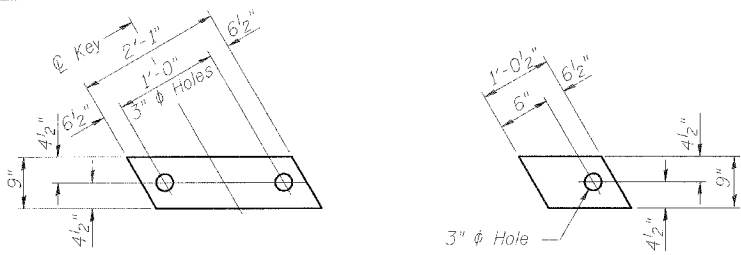

FABRIC BEARING PAD
(Interior)

FABRIC BEARING PAD
(Exterior)

FIXED

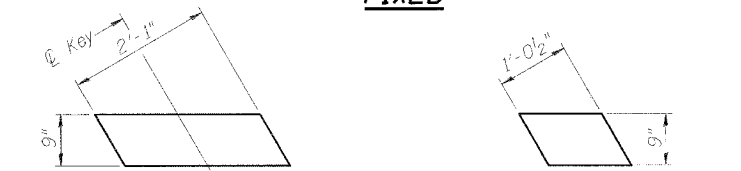

FABRIC BEARING PAD
(Interior)

FABRIC BEARING PAD
(Exterior)

EXPANSION

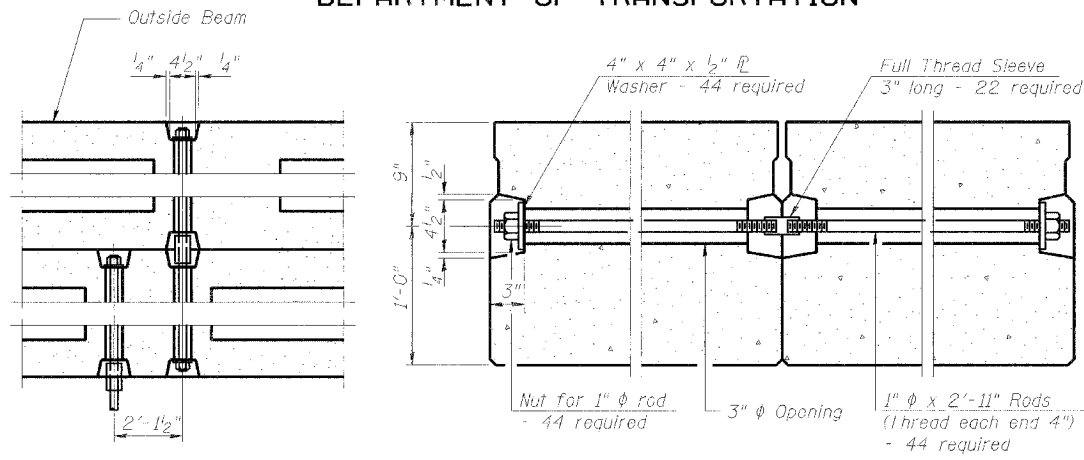

TYPICAL TRANSVERSE TIE ASSEMBLY

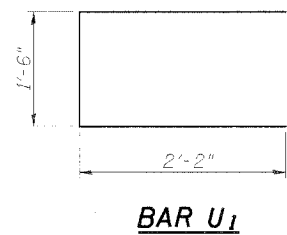

BAR U1

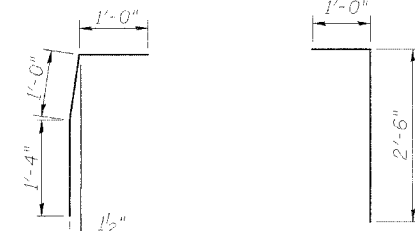

BAR D1(E)

BAR D2(E)

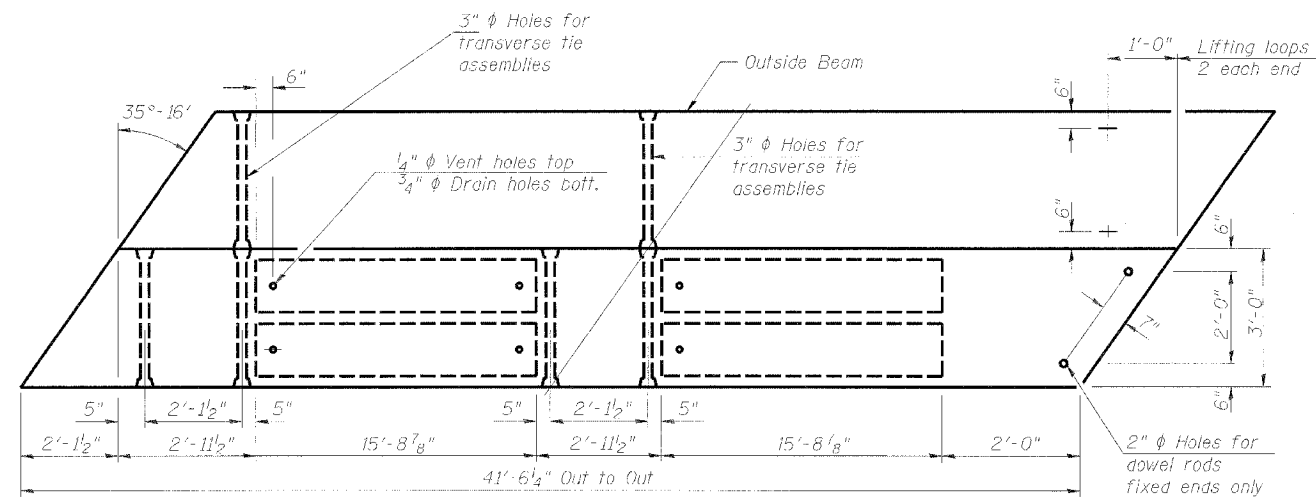

PLAN

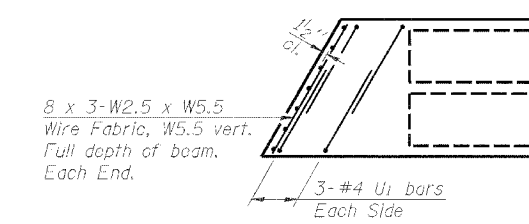

END PLAN

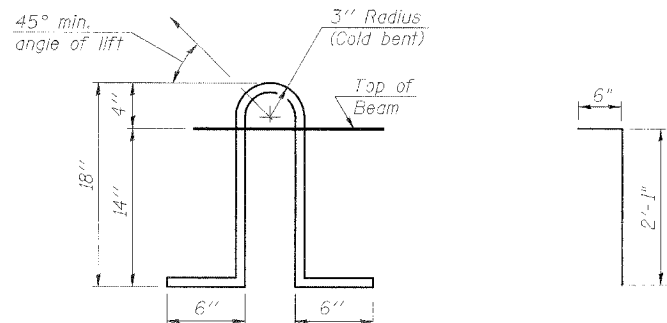

LIFTING LOOP DETAIL

BAR D(E)

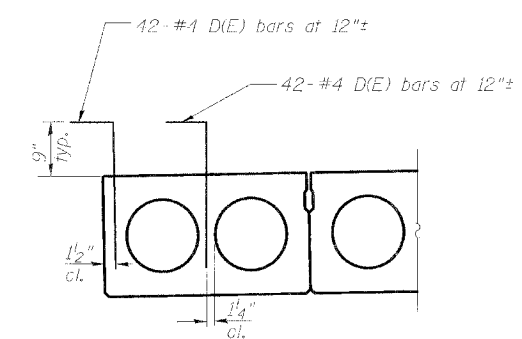

SECTION THRU WEST EXTERIOR BEAMS

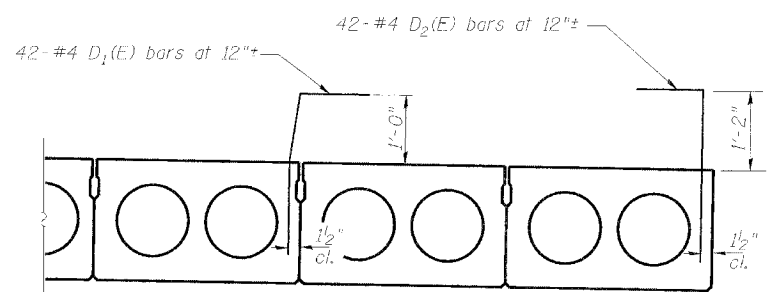

SECTION THRU EAST EXTERIOR BEAMS

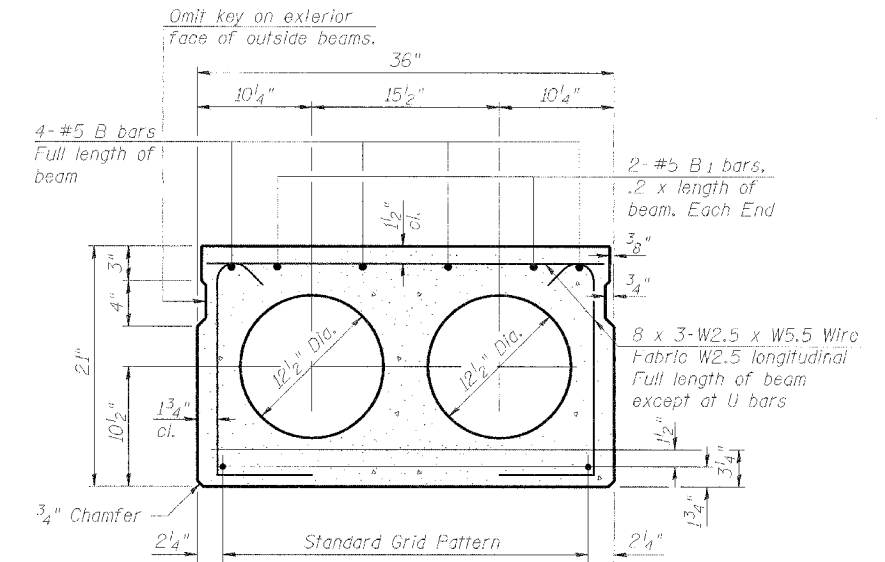

TYPICAL SECTION

10 - 1/2" ϕ Strands, Each Strand Stressed to 30,900 Lbs.
6 - Strands 1 3/4" up, 4 - Strands 3/4" up

Note: Place strands symmetrically about ϕ of beam.

NOTES

- Prestressing steel shall be uncoated high strength, low relaxation 7-wire strand, Grade 270. The nominal diameter shall be 1/2" and the nominal cross-sectional area shall be 0.153 sq. in. Lifting loops shall be 2-1/2" ϕ -270 ksi strands, as shown.
- The 1" ϕ rods in the transverse tie assembly shall be tightened to a snug fit and the threads set. Pockets that receive transverse tie bar on outside shall be filled with grout after transverse tie assembly is in place.
- Non prestressing steel shall conform to ASTM A 706 (IL MOD), Grade 60.
- The bearing seat surfaces shall be adjusted by shimming to assure firm and even bearing. Two 1/8" fabric adjusting shims of the dimensions of the Exterior Bearing Pad shall be provided for each bearing.
- Keyway surfaces shall be cleaned to remove form oil or other bond breaking material prior to shipment of the beams. Cleaning shall be done by sandblasting the keyway areas between top of the beam and the bottom edge of the key.
- Corrosion inhibitor, per Article 1020.05(b)(12) of the Standard Specifications, shall be used in the concrete for precast prestressed concrete deck beams.
- Required Release Strength, f'_{cr} , shall be 4000 p.s.i.

BILL OF MATERIAL

Precast Prestressed Conc. Deck Bms. (21" Depth)	Sq. Ft.	1495
---	---------	------

SUPERSTRUCTURE DETAILS: SPAN 7
F.A.P. 368 (PULASKI ROAD)
OVER BRC RAILROAD,
SECTION 1919 VB-R-1,
COOK COUNTY, STA. 17+81.60
STRUCTURE NO. 016-1020

STS Consultants
111 NE Jefferson Ave.
Peoria, Illinois 61602
Ph(309)676-8464
FAX(309)676-5445
IL Design Firm Reg. No. 184-001518

DESIGNED	DDB
CHECKED	LLV
DRAWN	MGM
CHECKED	DDB