

F.A. RTE.	SECTION	COUNTY	TOTAL SHEETS	SHEET NO.
1602	74 B-1	COOK	34	23
STA.		TO STA.		
FED. ROAD DIST. NO.		ILLINOIS FED. AID PROJECT		

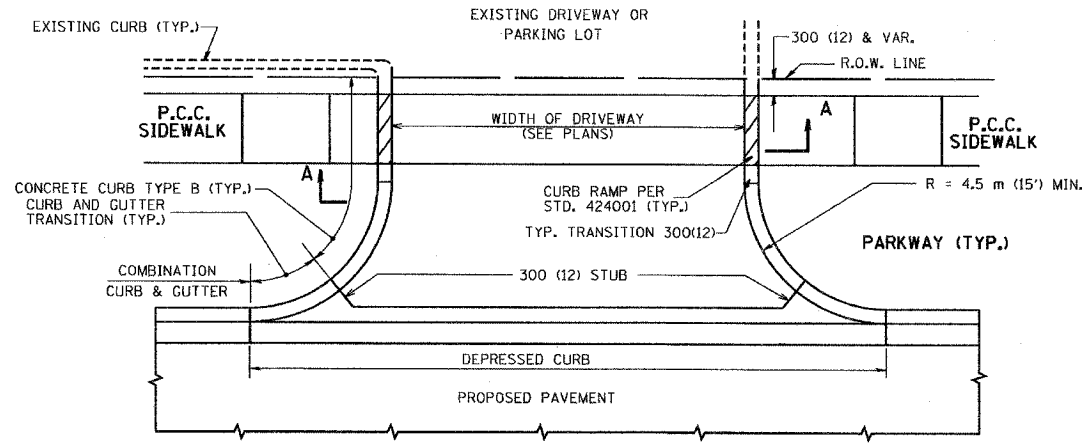

WITH CONCRETE CURB, TYPE B

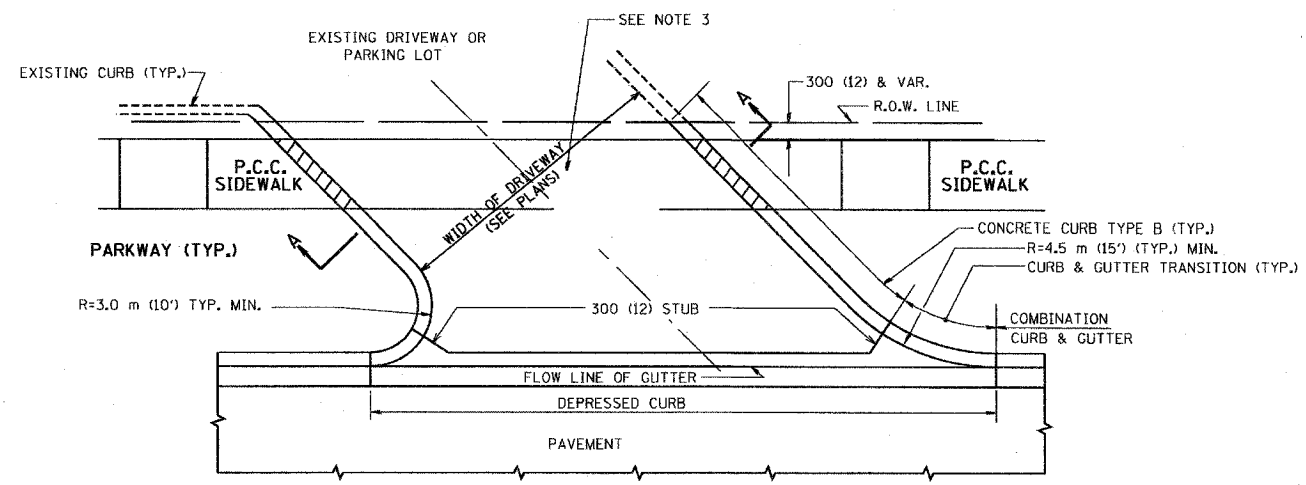

WITH CONCRETE CURB, TYPE B

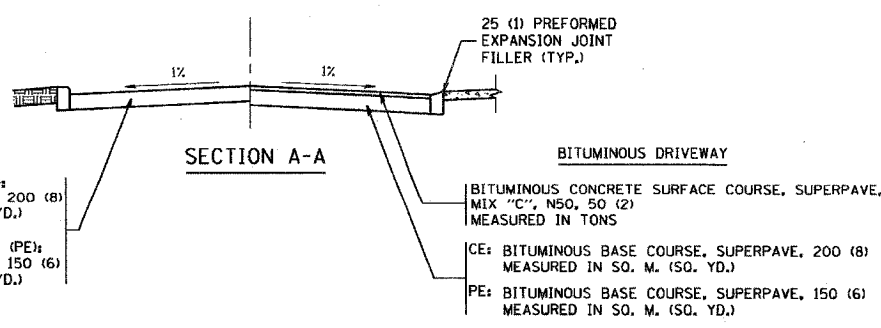

RIGID DRIVEWAY
 COMMERCIAL ENTRANCE (CE):
 P.C.C. DRIVEWAY PAVEMENT 200 (8)
 MEASURED IN SO. M. (SQ. YD.)
 NON-COMMERCIAL ENTRANCE (PE):
 P.C.C. DRIVEWAY PAVEMENT 150 (6)
 MEASURED IN SO. M. (SQ. YD.)

BITUMINOUS DRIVEWAY
 BITUMINOUS CONCRETE SURFACE COURSE, SUPERPAVE,
 MIX "C", N50, 50 (2)
 MEASURED IN TONS
 CE: BITUMINOUS BASE COURSE, SUPERPAVE, 200 (8)
 MEASURED IN SO. M. (SQ. YD.)
 PE: BITUMINOUS BASE COURSE, SUPERPAVE, 150 (6)
 MEASURED IN SO. M. (SQ. YD.)

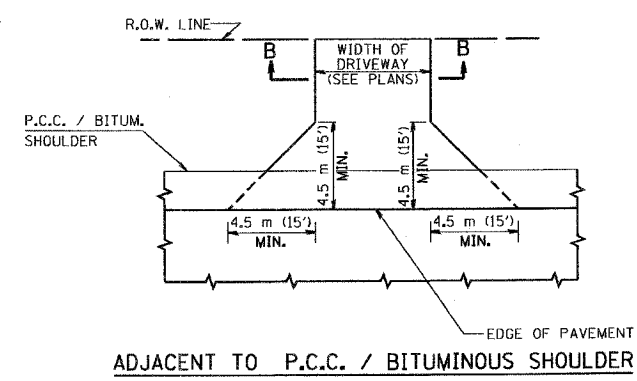

ADJACENT TO P.C.C. / BITUMINOUS SHOULDER

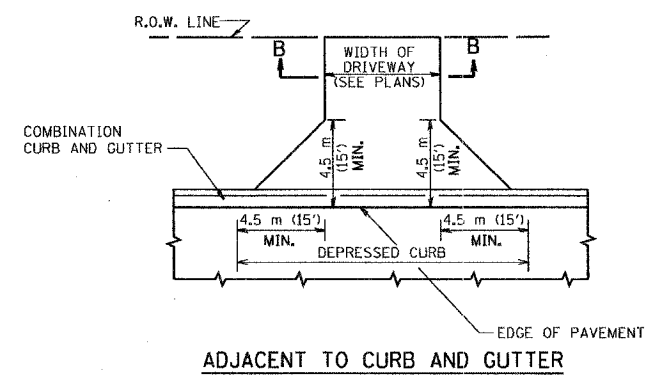

ADJACENT TO CURB AND GUTTER

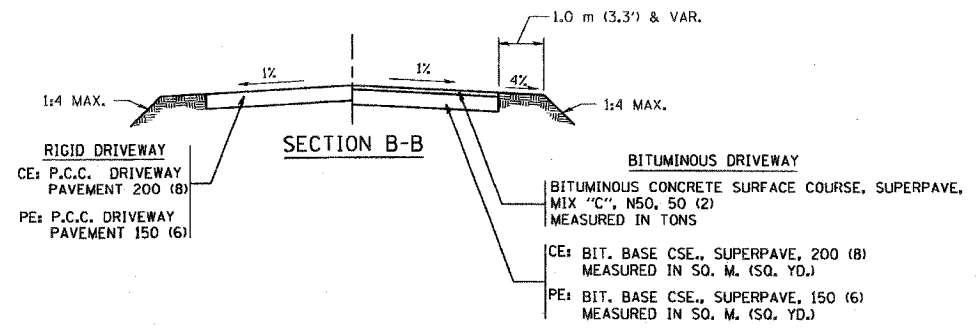

RURAL FIELD ENTRANCE (FE)
 BITUMINOUS CONCRETE SURFACE COURSE, SUPERPAVE
 MIX "C", N50, 50 (2)
 MEASURED IN TONS
 AGGREGATE BASE CSE., TYPE A 200 (8)
 MEASURED IN SO. M. (SQ. YD.)

GENERAL NOTES:

DRIVEWAY SLOPES, LOCATIONS, & GEOMETRIC LAYOUT SHALL BE IN ACCORDANCE WITH THE LATEST EDITION OF THE "HANDBOOK FOR POLICY ON PERMITS FOR ACCESS DRIVEWAYS TO STATE HIGHWAYS". FOR FURTHER LAYOUT REQUIREMENTS, REFER TO ILLUSTRATIONS IN THE PERMIT HANDBOOK. DRIVEWAYS SHALL BE REPLACED IN KIND, UNLESS OTHERWISE NOTED ON THE PLANS.

COMMERCIAL DRIVEWAYS SHALL BE CONSTRUCTED WITH CONCRETE CURB, TYPE B RETURNS EXCEPT WHEN THE SIDEWALK EDGE IS 1.2 METERS (4 FEET) OR LESS FROM THE BACK OF CURB, CONSTRUCT A FLARE DRIVEWAY WITHOUT CURB.

THE RESIDENT ENGINEER SHALL CONTACT THE TRAFFIC PERMIT OFFICE AT 847/ 705-4131 FOR ANY QUESTIONS ON DRIVEWAYS SHOWN IN THE PLANS; SPECIFICALLY IN REFERENCE TO ADDITIONAL AND/OR RELOCATION/REMOVAL OF A DRIVEWAY.

COMBINATION CONCRETE CURB & GUTTER SHALL BE MEASURED STRAIGHT ACROSS THE DRIVEWAY. NO ADDITIONAL COMPENSATION WILL BE ALLOWED FOR THE CURB & GUTTER TRANSITION.

25 (1) PREFORMED EXPANSION JOINT FILLER WILL NOT BE PAID SEPARATELY, BUT SHALL BE CONSIDERED INCLUDED IN THE COST OF THE P.C.C. DRIVEWAY PAVEMENT OR P.C.C. SIDEWALK.

WHEN THE P.C.C. SIDEWALK EXTENDS THROUGH THE DRIVEWAY, THE THICKNESS OF THE SIDEWALK IN THE DRIVEWAY AREA SHALL BE THE SAME AS THE DRIVEWAY THICKNESS. SIDEWALK WILL BE PAID FOR AS P.C.C. SIDEWALK OF THE THICKNESS SPECIFIED. SIDEWALK CROSS SLOPE THRU DRIVEWAY AREA TO BE A MAXIMUM OF 1:50.

ALL DIMENSIONS ARE IN MILLIMETERS (INCHES) UNLESS OTHERWISE NOTED

REVISIONS	
NAME	DATE
P. Lofleur	04-15-03
R. SHAH	11-04-95
J. POLLASTRINI	08-12-96
J. POLLASTRINI	12-14-96
A. ABBAS	03-21-97
T. HOLTZ	04-08-97
M. GOMEZ	04-06-01

ILLINOIS DEPARTMENT OF TRANSPORTATION
DRIVEWAY DETAILS
 DISTANCE BETWEEN R.O.W. AND FACE OF CURB / EDGE OF SHOULDER >= 4.5 m (15')

SCALE: VERT.
 CHECKED BY
 DATE: 2/15/2006

DRAWN BY
 CHECKED BY

BD400-01 (BD-01)
 REVISION DATE: 04/15/03

PLOT DATE = 2/15/2006
 FILE NAME = M:\projects\bd01.dgn
 PLOT SCALE = 48.9999 / IN.
 USER NAME = gajjendran