**STRUCTURE GEOTECHNICAL REPORT
ILLINOIS ROUTE 2 BRIDGES
OVER THE ROCK RIVER
EX SN 101-0125 & 101-0126
PR SN 101-0221 & 101-0222
WINNEBAGO COUNTY, ILLINOIS**

**For
HDR Engineering, Inc.
9450 West Bryn Mawr Avenue, Suite 400
Rosemont, IL 60018**

**Submitted by
Wang Engineering, Inc.
1145 North Main Street
Lombard, IL 60148**

**Original Report: December 18, 2019
Revised Report: January 27, 2021**

Technical Report Documentation Page

1. Title and Subtitle Structure Geotechnical Report, Illinois Route 2 Bridges over the Rock River		2. Original Date: December 18, 2019 Revised Date: January 27, 2021
		3. Report Type <input checked="" type="checkbox"/> SGR <input type="checkbox"/> RGR <input checked="" type="checkbox"/> Draft <input type="checkbox"/> Final <input type="checkbox"/> Revised
4. Route / Section / County IL2/ 77-1B/ Winnebago		5. Contract D-92-022-15
6. PTB / Item No. 176/011	7. Existing Structure Number(s) SN 101-0125 & 101-0126	8. Proposed Structure Number(s) SN 101-0221 & 101-0222
9. Prepared by Wang Engineering, Inc. 1145 N Main Street Lombard, IL 60148	Contributor(s) Author: Mickey L. Snider, PE QC/QA: Corina T. Farez, PE, PG PM: Mickey L Snider, PE	Contact (630) 953-9928 ext. 1027 msnider@wangeng.com
10. Prepared for HDR Engineering, Inc. 9450 W Bryn Mawr Ave Rosemont, IL, 60018	Contact Lance Peterman, PE, SE	Contact (773) 380-7940 Lance.Peterman@hdrinc.com
11. Abstract <p>The existing, 5-span bridges carrying southbound and northbound Illinois Route 2 over the Rock River will be removed and replaced with new, 3-span structures. The new structures will be slightly longer than the existing at 592.1 feet back-to-back of abutments and will have out-to-out widths of 43.2 and 53.9 feet. The profile grade along the bridge will not be changed by more than one to two feet. The side slopes grade out gently at about 1:4 (V:H) and will only be lightly graded; the end slopes will be cut back to 1:2 (V:H) and armored with riprap. This report provides geotechnical recommendations for the design and construction of the proposed bridge and approach embankments.</p> <p>The bridge decks are approximately 20 feet above the surface of the river. The soil profile along the bridge is almost exclusively granular, with 12 to 17 feet of sand and sandy gravel fill along the existing embankments overlying deep, sand and sandy gravel foundation soils extending essentially to the termination depths of the borings at depths of 100-plus feet below the roadway elevation. A thin layer of soft, silty clay river floodplain soil was encountered at the base of the fill along the south side. The D50 value of the streambed soils ranges from 0.65 to 7mm. Bedrock was not encountered within the limits of the investigation. The groundwater level was measured at elevations ranging from 724 and 716 feet, and the Estimated Water Surface Elevation at the time of drilling was 714.1 feet.</p> <p>The bridge substructures should be supported on driven piling. Based on IDOT criteria we estimate the bridges could be designed with integral abutments; the pile types for integral abutments would be limited to HP14x117 or 16-inch diameter MSP. Stub abutments could utilize a wider range of pile types and sizes, but due to the deep deposits of higher N-value granular soils we recommend 16-inch diameter MSP be strongly considered regardless of abutment type. The MSP have estimated lengths of about 15 to 50 feet, whereas steel H-piles will drive between 50 and 120 feet. The approach embankment grades will not be changed by more than one to two feet and will not undergo long-term settlement. The end slopes have adequate global stability FOS and are armored with riprap to prevent scour and sloughing.</p> <p>The four proposed piers will be constructed within the river. The river depth down to the streambed at the time of drilling was approximately 10 feet; the pier cap excavations will require the pay item, <i>Type 2 Cofferdam</i> and will require a seal coat with a minimum thickness of at least 5 feet.</p>		
12. Path to archived file S:\Netprojects\7510701\Reports\RPT_Wang_MLS_7510701IL2RockRiver_20191205.doc		

TABLE OF CONTENTS

1.0	INTRODUCTION.....	1
1.1	PROPOSED STRUCTURE.....	1
1.2	EXISTING STRUCTURE AND LAND USE	2
2.0	GEOLOGICAL SETTING	2
2.1	PHYSIOGRAPHY	2
2.2	SURFICIAL COVER	3
2.3	BEDROCK.....	3
3.0	METHODS OF INVESTIGATION.....	3
3.1	FIELD INVESTIGATION.....	4
3.2	LABORATORY TESTING.....	4
4.0	INVESTIGATION RESULTS.....	5
4.1	LITHOLOGICAL PROFILE.....	5
4.2	GROUNDWATER CONDITIONS.....	6
5.0	FOUNDATION ANALYSIS AND RECOMMENDATIONS.....	6
5.1	SEISMIC DESIGN CONSIDERATIONS	7
5.2	SCOUR CONSIDERATIONS.....	7
5.3	APPROACH EMBANKMENTS	9
5.3.1	<i>Settlement.....</i>	9
5.3.2	<i>Global Stability.....</i>	10
5.4	STRUCTURE FOUNDATIONS	10
5.4.1	<i>Approach Slab Bents</i>	10
5.4.2	<i>Driven Piles.....</i>	11
5.4.3	<i>Lateral Loading.....</i>	29
5.5	STAGE CONSTRUCTION.....	29
6.0	CONSTRUCTION CONSIDERATIONS	30
6.1	SITE PREPARATION	30
6.2	EXCAVATION, DEWATERING AND UTILITIES.....	30
6.3	FILLING AND BACKFILLING.....	30
6.4	EARTHWORK OPERATIONS	31
6.5	PILE INSTALLATION	31

7.0	QUALIFICATIONS.....	31
	REFERENCES	33
	EXHIBITS	
	1. <i>SITE LOCATION MAP</i>	
	2. <i>SITE AND REGIONAL GEOLOGY</i>	
	3. <i>BORING LOCATION PLAN</i>	
	4. <i>SOIL PROFILE</i>	
	APPENDIX A	
	<i>BORING LOGS</i>	
	APPENDIX B	
	<i>LABORATORY TEST RESULTS</i>	
	APPENDIX C	
	<i>GLOBAL STABILITY ANALYSIS</i>	

LIST OF TABLES

Table 1: Seismic Design Parameters	7
Table 2: Northbound IL2 Scour Data	8
Table 3: Northbound IL2 Design Scour Elevations	8
Table 4: Southbound IL2 Scour Data	9
Table 5: Southbound IL2 Design Scour Elevations	9
Table 6: Preliminary Service Loading for Northbound Bridge	10
Table 7: Preliminary Service Loading for Southbound Bridge	11
Table 8: Estimated Pile Lengths and Tip Elevations for 14-inch MSP w/.312-inch walls.....	13
Table 9: Estimated Pile Lengths and Tip Elevations for 16-inch MSP w/.312-inch walls.....	15
Table 10: Estimated Pile Lengths and Tip Elevations for HP12x53 Steel Abutment Piles.....	18
Table 11: Estimated Pile Lengths and Tip Elevations for HP12x63 Steel Piles.....	21
Table 12: Estimated Pile Lengths and Tip Elevations for HP14x73 Steel Piles.....	24
Table 13: Estimated Pile Lengths and Tip Elevations for HP14x117 Steel Piles.....	26
Table 14: Recommended Soil Parameters for Lateral Load Analysis	29

**STRUCTURE GEOTECHNICAL REPORT
ILLINOIS ROUTE 2 BRIDGES
OVER THE ROCK RIVER
EX SN 101-0125 (SB) & 101-0126 (NB)
PR SN 101-0221 (SB) & 101-0222 (NB)
WINNEBAGO COUNTY, ILLINOIS
FOR
HDR ENGINEERING, INC.**

1.0 INTRODUCTION

This report presents the results of our subsurface investigation, laboratory testing, geotechnical evaluations, and recommendations to support the design and reconstruction of the proposed southbound (SN 101-0125) and northbound (SN 101-0126) Illinois Route 2 (IL2) Bridges over the Rock River in Winnebago County, Illinois. A *Site Location Map* is presented as Exhibit 1.

1.1 Proposed Structure

Based on the General Plan and Elevation (GPE) drawings provided by HDR Engineers, Inc. (HDR) in October 2019, Wang Engineering, Inc. (Wang) understands the two existing 5-span bridges will be completely removed and replaced with new structures. The new bridges will be 3-span structures with stub-type abutments and solid wall piers constructed within the river. The structures will both have back-to-back of abutment lengths of 592.1 feet, with end spans of 180 feet and a center span of 224 feet. The out-to-out width of the east bridge will measure 43.2 feet, while the west bridge will be wider at 53.9 feet to accommodate a 10-foot wide shared use path along the west edge. Both bridges will have 34 feet of traffic lane and 6-foot wide shoulders on both sides.

The profile grade along the bridges will not change by more than one to two feet. The side slopes currently grade out gently at approximately 1:4 (V:H) and they will be maintained at the same geometry. The end slopes will be shaped to provide 1:2 (V:H) slopes down to the river and will be armored with rip-rap to a level below the water surface elevation. The new abutments will be constructed about 5 to 10 feet behind the existing ones and we anticipate that the existing abutments will be removed. The piles can be cut off 2 feet below the proposed end slope grade and remain in place.

1.2 Existing Structure and Land Use

The existing bridges are dual, 5-span structures built in 1965. The bridges have spill-through, pile supported vaulted abutments and four solid wall piers each with large, driven pile-supported footings. The existing bridges have back-to-back lengths of 563 feet, or approximately 30 feet less than the proposed structures. The surrounding land is entirely undeveloped, with thick tree cover to each side except for the southeast corner; the existing side slopes are in good shape, although the end slope concrete shows considerable wear. The Rock River channel is approximately 480 feet wide.

The purpose of this investigation was to characterize the site soil and groundwater conditions, perform geotechnical analyses, and provide recommendations for the design and construction of the proposed bridge, approach embankments, and slabs.

2.0 GEOLOGICAL SETTING

The project area is located in north-east Winnebago County, within the limits of the Village of Rockton. On the USGS *South Beloit Quadrangle 7.5 Minute Series* map, the project is located in the W1/2 of Section 19, Tier 26 N, Range 2 E of the Third Principal Meridian.

The following review of published geologic data, with emphasis on factors that might influence the design and construction of the proposed engineering works, is meant to place the project area within a geological framework and, thus, to confirm the dependability and consistency of the present subsurface investigation results. For the study of the regional geologic framework, Wang considered northeastern Illinois area in general and Winnebago County in particular.

2.1 Physiography

The project area is in the Rock River Hill Country Subsection. The Rock River Hill Country is characterized by subdued rolling hills, with few well-developed drainage networks in the uplands, and mostly steep slopes exist near larger streams such as the Rock River. The IL 2 Bridge over the Rock River is located within the flat Rock River floodplain and connects the residential areas on each side of the river. The elevation at roadway level varies between 740 to 733 feet. The bridge spans over approximately a 400-foot wide river channel with steep slopes. The water level recorded at the Rockton Gage on May 31, 2016 shows a surface elevation of 711.78 feet.

2.2 Surficial Cover

The project site lies atop the confluence of two major bedrock valleys Rock and Pecatonica Bedrock Valleys, which were incised prior to glaciation. Exhibit 2 illustrates the *Site and Regional Geology*. The bedrock valleys are now largely filled with sediments. The uppermost soils are poorly-sorted sand and gravel of the Cahokia Alluvium overlying the glaciofluvial outwash deposits, primarily sands and gravels of the Mackinaw Member of the Henry Formation. The Mackinaw sand and gravel, in turn, rests directly over the bedrock. Local deposits of well-bedded clay and silt of the Equality Formation can be encountered, although not likely at the IL 2 Bridge site, resting on top of the till as a result of the quiet water deposition of glacial lakes. Mainly, the till in Winnebago County consist of pink to tan, sandy loam and gravel diamicton associated with the Argyle Till Member of the Winnebago Formation (Lineback, 1979). The *Site and Regional Geology* is illustrated in Exhibit 2.

2.3 Bedrock

The uppermost bedrock unit in Winnebago County consists of Ordovician-age sandstone, limestone, and dolomite (McGarry, 2000). The dominant formations include dolomites associated with the Platteville Group, which have a thickness up to 130 feet, and quartz sandstones associated with the Ancell Group, which is 200 to 400 feet thick. The IL 2 Bridges are located on the southern slope of the bedrock valley, with top of bedrock elevations ranging from approximately 600 to 650 feet, meaning the bedrock may be found at about 70 to 120 feet below ground surface (bgs). Outside the bedrock valley, and within 1000 yards south of the bridges, bedrock may be encountered at depths as shallow as 15 feet bgs. Approximately 2250 yards north, IL 2 crosses deepest point in the valley, with the top of rock situated at an elevation below 500 feet, or 270 feet bgs (McGarry, 2000). The bedrock slope is approximately 100 feet per mile.

Our subsurface investigation results fit into the local geologic context. The borings drilled in the project area encountered native sediments consisting of deep granular deposits associated with the Cahokia Alluvium and Henry Formations. The structure borings drilled on site did not encounter bedrock at depths of greater than 100 feet below the IL2 roadway elevation.

3.0 METHODS OF INVESTIGATION

The following sections outline the subsurface and laboratory investigations performed by Wang.

3.1 Field Investigation

The subsurface investigation consisted of eight bridge borings, designated as 0125-BSB-01 through 0125-BSB-04 along the SB Bridge and 0126-BSB-01 through 0126-BSB-04 along the NB Bridge. The borings were drilled by Wang in October and November of 2019. The borings were drilled from elevations of 735.7 to 736.4 feet and were advanced to depths of 100 to 130 feet bgs. The as-drilled northings, eastings, and elevations were acquired with a mapping-grade GPS unit.. Stations and offsets were determined from design drawings provided by HDR. Boring location data are presented in the *Boring Logs* (Appendix A) and the as-drilled boring locations are shown in the *Boring Location Plan* (Exhibit 3).

Truck-mounted drilling rigs, equipped with hollow stem augers and rotary drilling equipment, were used to advance and maintain open boreholes. At the piers, Wang cored 4-inch diameter holes through the existing bridge decks and set casing between the deck and Rock River streambed. Soil sampling was performed according to AASHTO T206, "*Penetration Test and Split Barrel Sampling of Soils.*" The soil was sampled at 2.5-foot intervals to 30 feet bgs and at 5.0-foot intervals from 30 feet to the boring termination depth. Soil samples collected from each sampling interval were placed in sealed jars and transported to the laboratory for further examination and laboratory testing.

Field boring logs, prepared and maintained by Wang geologists, include lithological descriptions, visual-manual soil (IDH Textural) classifications, results of Rimac and pocket penetrometer unconfined compressive strength tests, and results of Standard Penetration Tests (SPT) recorded as blows per 6 inches of penetration.

Groundwater levels were measured while drilling and at completion of each boring. The boreholes were backfilled with grout upon completion and, where necessary, the pavement surface was restored to its original condition. The existing bridge decks were patched with concrete.

3.2 Laboratory Testing

The soil samples were tested in the laboratory for moisture content (AASHTO T265). Particle size (AASHTO T88) analyses were performed on selected streambed samples to provide data for scour analysis. Field visual descriptions of the soil samples were verified in the laboratory. Laboratory test results are shown in the *Boring Logs* (Appendix A) and in the *Laboratory Test Results* (Appendix B).

4.0 INVESTIGATION RESULTS

Detailed descriptions of the soil conditions encountered during the subsurface investigation are presented in the attached *Boring Logs* (Appendix A) and in the *Soil Profiles* (Exhibit 4). Please note that strata contact lines represent approximate boundaries between soil types. The actual transition between soil types in the field may be gradual in horizontal and vertical directions.

4.1 Lithological Profile

The borings drilled behind the existing abutments encountered 2 to 3 inches of asphalt pavement over 11 to 12 inches of concrete and a further 12 to 18 inches of aggregate base. The bridge deck cores were 10 inches of concrete. In descending order, the general lithologic succession encountered beneath the topsoil or pavement includes: 1) man-made ground (fill); 2) loose to medium dense sand and sandy gravel; 3) dense to very dense sand and sandy gravel; and 4) very dense silt.

1) Man-made ground (fill)

Behind the existing abutments the borings encountered 12 to 17 feet of loose to dense, brown sand and sandy gravel fill. The fill has a wide range of density, with the two borings drilled to the south of the bridge measuring N-values of 2 to 22 blows per foot of penetration, while the borings drilled on the north side measured N-values of 21 to 44 blows per foot of penetration. The northern borings revealed larger gravel fractions within the samples, which likely explains the higher blow counts.

The proposed abutments will be set within the fill material on sand and sandy gravel with N-values of 5 to 40 blows per foot. These sands were encountered damp to moist, with the static groundwater level being encountered within natural soils below.

2) Loose to medium dense sand and sandy gravel

Below elevations of 724 to 719 feet, the borings encountered deep deposits of natural sand and sandy gravel. The initial 40 to 50 feet of sand and sandy gravel has loose to medium dense consistency, with N-values from 6 to 29 blows per foot and an average of about 15 to 17 blows per foot. The larger-grained sandy gravel deposits were generally encountered higher, at an elevation above 700 feet. The sandy gravel makes up the potentially scourable streambed of the river and particle size analyses show D_{50} values ranging from 0.65 to 7 mm.

The abutment borings on the south side of the bridge, drilled through the existing embankment, both

encountered thin, single-sample layers of soft, brown silty clay loam floodplain deposits at depths of about 17 feet below the roadway elevation. The silty clay loam has Q_u values of about 0.2 to 0.4 tsf and moisture content values of 20 to 24%. These deposits are too deep to influence the settlement of the embankment considering the minor proposed grade changes.

3) Dense to very dense sand and sandy gravel

At elevations of 670 to 655 feet, the sand and sandy gravel in the borings grades to a dense and very dense consistency. This dense to very dense granular soil has N-values exclusively greater than 30 blows per foot and extends to an elevation of 630 feet, where a thin, 5-foot thick deposit of hard, gray silty clay was encountered.

4) Very dense silt

Beneath the silty clay layer representing the bottom of the sand and sandy gravel, the borings encountered very dense, gray silt continuing to the termination depths of the borings. The silt has N-values of 40 to 65 blows per foot.

4.2 Groundwater Conditions

The Estimated Water Surface Elevation (EWSE) within the Rock River was measured at an elevation of approximately 714.1 feet. Groundwater was encountered while drilling at elevations of 724 to 716 feet within the loose to medium dense sand and sandy gravel, consistent with the levels recorded in the river. The sand and silt layers beneath the fill, including those encountered deep (**Layer 5**) are saturated and water bearing. Excavations and drilling into these soils will encounter caving and groundwater infiltration if advance provisions are not made for the control of groundwater.

5.0 FOUNDATION ANALYSIS AND RECOMMENDATIONS

Geotechnical evaluations and recommendations for the approach embankments, approach slabs, and substructure foundations are presented in the following sections. The approach embankment grades will not be changed by more than 1 to 2 feet. The new end slope will be graded down at 1:2 (V:H), while the side slopes have maximum heights of about 6 feet and grade down to ditches at a maximum of 1:4 (V:H).

We recommend supporting the substructures on driven piling. Due to the deep, granular nature of the soil and the persistent groundwater present at the site, we do not recommend installing drilled shafts.

The estimated embankment settlements will be less than 0.4 inches and there are no limitations on pile placement or depth due to downdrag allowances. Bedrock was not encountered as deep as 100 feet below the channel bottom and 130 feet below the back of abutment elevation, and based on IDOT experience driving steel H-Piles in these conditions, the larger, concrete-filled metal shell pile (MSP) options should be seriously considered for support of the bridge foundations.

5.1 Seismic Design Considerations

The seismic site class was determined in accordance with the IDOT *All Geotechnical Manual Users (AGMU) 9.1* (IDOT 2009) method of analysis. The soils within the top 100 feet have a weighted average N-value of 29 blows/foot (AASHTO 2015; Method C controlling), and the results classify the site in the Seismic Site Class D.

The project location belongs to the Seismic Performance Zone 1. The seismic spectral acceleration parameters recommended for design in accordance with AASHTO (2018) are summarized in Table 1. According to the IDOT *Bridge Manual* (2012), liquefaction analysis is not required for a site located in Seismic Performance Zone 1.

Table 1: Seismic Design Parameters

Spectral Acceleration Period (sec)	Spectral Acceleration Coefficient ¹⁾ (% g)	Site Factors	Design Spectrum for Site Class D ²⁾ (% g)
0.0	PGA= 3.5	$F_{pga}= 1.6$	$A_s= 5.7$
0.2	$S_s= 7.6$	$F_a= 1.6$	$S_{DS}= 12.2$
1.0	$S_1= 3.1$	$F_v= 2.4$	$S_{D1}= 7.5$

1) Spectral acceleration coefficients based on Site Class D

2) Site Class D Spectrum to be included on plans; $A_s = PGA * F_{pga}$; $S_{DS} = S_s * F_a$; $S_{D1} = S_1 * F_v$

5.2 Scour Considerations

A hydraulic report was prepared for the Department in June 2016 and provided to Wang by HDR. The report provides 100- and 200-year contraction and pier scour results for both the northbound and southbound structures. The scour depth estimates along both bridges are highly uniform, with the 100 and 200 year values each varying between only 6.50 to 6.75 feet; these results place the Q100

and Q200 scour elevations at about 695.5 to 690.0 feet. The abutment end slopes will be armored with rip rap as shown in the plans and the scour elevations should be at the proposed abutment base elevations. The scour data provided in the GPE plan and hydraulic report are summarized in Tables 2 and 4, while the Q100, Q200, Design and Check scour elevations, as required in accordance with IDOT *All Bridge Designers Memo 14.2*, are provided in Tables 3 and 5. The D_{50} values measured from laboratory testing range from 0.65mm at Pier 1 along the SB Bridge, to 5 to 7mm at the other three piers. We do not recommend any reductions to the design scour depths at this time. The design high water elevation (DHWE) is 723.2 feet and the EWSE within the channel is 716 feet. The streambed elevation within the river is 706 to 707 feet.

Table 2: Northbound IL2, SN 101-0222 Scour Data

	South Abutment	Pier 1	Pier 2	North Abutment
Streambed Elevation (feet)	NA	703.1	703.1	NA
Footing Base Elevation (feet)	723.3	698.9	698.9	724.1
100-year Combined Scour Estimate (feet)	4.11	6.50	6.55	4.11
200-year Combined Scour Estimate (feet)	7.67	6.61	6.66	7.67

Table 3: Northbound IL2, SN 101-0222 Design Scour Elevations

	South Abutment	Pier 1	Pier 2	North Abutment	Item 113
Q100 Elevation (feet)	723.3	696.6	696.6	724.1	
Q200 Elevation (feet)	723.3	696.5	696.4	724.1	
Design Elevation (feet)	723.3	696.6	696.6	724.1	5
Check Elevation (feet)	723.3	696.5	696.4	724.1	

Table 4: Southbound IL2, SN 101-0221 Scour Data

	South			North
	Abutment	Pier 1	Pier 2	Abutment
Streambed Elevation (feet)	NA	703.1	703.1	NA
Footing Base Elevation (feet)	723.3	698.9	698.9	723.7
100-year Combined Scour Estimate (feet)	5.32	6.68	6.69	5.32
200-year Combined Scour Estimate (feet)	6.91	6.73	6.73	6.91

Table 5: Southbound IL2, SN 101-0221 Design Scour Elevations

	South			North	Item
	Abutment	Pier 1	Pier 2	Abutment	
Q100 Elevation (feet)	723.3	696.4	696.4	723.7	113
Q200 Elevation (feet)	723.3	696.4	696.4	723.7	
Design Elevation (feet)	723.3	696.4	696.4	723.7	5
Check Elevation (feet)	723.3	696.4	696.4	723.7	

5.3 Approach Embankments

Wang performed settlement and global stability evaluations for the approach embankments. The proposed embankments will be graded at side slopes of 1:4 (V:H) each side for a maximum of about 6 feet. The profile grade along the centerline will not be changed by more than a foot or two. The proposed top of pavement elevations along the back of the abutments ranges from 734.8 to 737.8 feet, or about 30 feet from the channel bottom at the base of the end slopes, which will be graded at 1:2 (V:H).

5.3.1 Settlement

The profile grade along the reconstructed IL2 will be essentially the same as the current grade. Little new embankment fill will be added and the embankment will not experience settlement greater than 0.4 inches. No downdrag allowances will be necessary on the piles.

5.3.2 Global Stability

The global stability of the south end slope was analyzed based on the soil profile described in Section 4.1 and the information provided in the GPE. The abutment end slopes are graded the same basic geometry, with the south end slope having lower N-values than the north end slope and the thin, softer floodplain layer; therefore, the south end slope represents the critical condition. The end slopes are graded at 1:2 (V:H) with the soft, floodplain soils intersecting the slope within the bottom third. Generally, the minimum required FOS for both short (undrained) and long-term (drained) conditions is 1.5 (IDOT 2012); the slope at IL2, however is almost entirely granular soil. Granular slopes should be protected from sloughing at the face, which is provided at IL2 by way of rip rap armoring, but are not at risk of deep foundation failures when well-drained and graded at 1:2 (V:H). *Slide v6.0* evaluation exhibits employing the Bishop Simplified method of analysis are shown in Appendix C, and we estimate the end slope has a minimum FOS of 1.3 (Appendix C-1). The failure surface does not extend through the soft clayey floodplain layer, and therefore, we estimate the FOS of 1.3 is adequate.

5.4 Structure Foundations

Wang recommends supporting the abutments on driven piles. The soil conditions along the structure show loose to medium dense sand and sandy gravel grading to dense and very dense sand and sandy gravel at about 655 to 670 feet.

5.4.1 Structure Loads

The preliminary service and factored loads information provided by HDR are summarized in Table 6. The proposed abutment cap base elevations shown in the GPE are 723.3 to 724.1 feet along the northbound bridge and 723.3 to 723.7 feet at the southbound bridge. The pier cap base elevation is 698.9 feet.

Table 6: Preliminary Service Loading for Northbound Bridge, SN 101-0222

Substructure	Factored Loading (kips)			Total Service Load
	Dead Load (DC)	Dead Load (DW)	Live Load w/out Impact	
South Abutment	913	210	578	1700
Pier 1	3625	750	1173	5548
Pier 2	3625	750	1173	5548

Substructure	Factored Loading (kips)			Total Service Load
	Dead Load (DC)	Dead Load (DW)	Live Load w/out Impact	
North Abutment	913	210	578	1700

Table 7: **Preliminary Service** Loading for Southbound Bridge, SN 101-0221

Substructure	Factored Loading (kips)			Total Service Load
	Dead Load (DC)	Dead Load (DW)	Live Load w/out Impact	
South Abutment	1088	255	595	1938
Pier 1	4313	885	1190	6388
Pier 2	4313	885	1190	6388
North Abutment	1088	255	595	1938

5.4.2 Driven Piles

The bridge geometry and conditions have been checked for the feasibility of integral abutments in accordance with IDOT *ABD Memorandum 19.8* (IDOT 2019). The bridge has a total length of 592 feet on a 25° skew and will incorporate 72-inch tall plate girder beams. The southbound bridge will include 7 total beams spaced at 7.9 inches on-center, while the northbound bridge will have 6 total beams spaced at 7.3 feet on-center. The bridge geometry details, as well as the soil data from the borings between elevations of 725 to 715 feet on the south side and 722 to 712 feet on the north side have been analyzed in the IDOT spreadsheet for *Integral Abutment Feasibility Analysis*. The analysis suggests the in-situ soil conditions produce a situation where the ‘equivalent Q_u value’ of the granular soils within the top 10 feet below the abutments is greater than 3.0, and therefore too stiff for integral abutments. These pile locations could, however, be precored to a depth of 10 feet below the base of the abutments and backfilled with bentonite in accordance with ABD 19.8 to produce a material with an equivalent Q_u value of 1.5 tsf. After the precore, the north abutments are suitable for the use of integral abutments, but will also be limited to HP117 or 16-inch diameter MSP options. The following section provides analyses and recommendations for both integral and stub-type abutments, although the integral abutment option will likely be preferred.

IDOT specifies the maximum nominal required bearing (R_{NMAX}) for each pile and states the factored resistance available (R_F) for steel H-piles and MSP should be based on a geotechnical resistance factor (ϕ_G) of 0.55 (2012). Nominal tip and side resistance were estimated using the methods and empirical equations presented in *AGMU Memorandum 10.2 – Geotechnical Pile Design* (IDOT 2015). For the integral abutment option, ABD 19.8 requires that one pile be placed below each beam, meaning the southbound bridge would include 7 piles, while the northbound bridge would include 6 piles. Based on the preliminary loads, we estimate the load per pile for the southbound bridge would be about 277 kips, while the load per pile at the northbound bridge would be about 283 kips. These numbers are approximate targets for pile analysis and should be confirmed by the structural designer prior to final design.

Stub abutments would include 2 rows of piles without the limitations for placement beneath the beams. Based on the abutment geometry the load per pile at the stub abutments will range between about 48 and 140 kips for two rows of piles spaced at 3- to 8-feet. The piers will have 2 rows of piles each and the load per pile will range between 162 and 458 kips for piles spaced at 3- to 8-feet.

The R_F estimates are governed by the relationship $R_F = \phi_G R_N - \phi_G (DD_R + S_C + L_{iq}) I_G - (\gamma_p)(\lambda_{IS}) DD_L$ (IDOT 2012). We estimate that less than 0.4 inches of settlement will remain following the construction of the embankment and subsequent pile driving; downdrag allowances will not be required for the piles.

The R_F , R_N , estimated pile tip elevations, and pile lengths for 14-inch diameter MSP, 16-inch diameter MSP, HP12x53, HP12x63, HP14x73, and HP14x117 steel H-piles are summarized in Tables 8 through 13. The lengths shown in the tables assume a 1-foot pile embedment into the pile cap. Recent IDOT experience has shown steel H-Piles driving very long in granular soil profiles such as the one revealed at IL2; the larger HP14 sized piles do not achieve maximum nominal bearing prior to the bottom of the investigation, which in some cases exceeds 110 feet below the substructure base. Generally, it is preferred that if H-Piles are to be recommended, that they terminate at the top of sound bedrock; however, bedrock was not encountered during the subsurface investigation and geologic maps indicate that it is likely dipping deeper in elevation quickly to the north (Section 2.3). Therefore, the top of bedrock elevation will be difficult to predict and may vary significantly across the length of the bridge. For these reasons, we strongly recommend considering the larger MSP sizes at each of the substructure locations.

Table 8: Estimated Pile Lengths and Tip Elevations for 14-inch MSP w/.312-inch walls

Structure Unit (Reference Boring)	Pile Cap Base Elevations (feet)	Required Nominal Bearing, R_N (kips)	Factored Geotechnical Loss (kips)	Factored Geotechnical Load Loss (kips)	Factored Resistance Available, R_F (kips)	Total Estimated Pile Length (feet)	Estimated Pile Tip Elevation (feet)
BN.125 South Abutment Wang-0125- BSB-01 & Wang-0125- BSB-02	723.3	570	0.0	0.0	314	49	675
		473	0.0	0.0	260	47	677
		436	0.0	0.0	240	44	680
		400	0.0	0.0	220	41	683
		291	0.0	0.0	160	26	698
BN.125 Pier 1 Wang-0125- BSB-02	698.9	570	0.0	0.0	314	44	656
		509	0.0	0.0	280	43	657
		436	0.0	0.0	240	35	665
		364	0.0	0.0	200	28	672
		291	0.0	0.0	160	23	677
BN.125 Pier 2 Wang-0125- BSB-03 NB Scour 696.44 loss=4 kip	698.9	570	0.0	0.0	314	53	647
		509	0.0	0.0	280	50	650
		436	0.0	0.0	240	43	657
		364	0.0	0.0	200	40	660
		291	0.0	0.0	160	33	667
BN.125 North Abutment Wang-0125- BSB-03 &	723.7	570	0.0	0.0	314	39	686
		473	0.0	0.0	260	30	695

Structure Unit (Reference Boring)	Pile Cap Base Elevations (feet)	Required Nominal Bearing, R_N (kips)	Factored Geotechnical Loss (kips)	Factored Geotechnical Load Loss (kips)	Factored Resistance Available, R_F (kips)	Total Estimated Pile Length (feet)	Estimated Pile Tip Elevation (feet)
Wang-0125-BSB-04		436	0.0	0.0	240	25	700
		400	0.0	0.0	220	23	702
		291	0.0	0.0	160	15	710
BN.126 South Abutment Wang-0126-BSB-01 & Wang-0126-BSB-02	723.3	570	0.0	0.0	314	44	680
		473	0.0	0.0	260	40	684
		436	0.0	0.0	240	40	684
		400	0.0	0.0	220	39	685
		291	0.0	0.0	160	30	694
BN.126 Pier 1 Wang-0126-BSB-02	698.9	570	0.0	0.0	314	43	657
		473	0.0	0.0	260	36	664
		436	0.0	0.0	240	35	665
		364	0.0	0.0	200	32	668
		291	0.0	0.0	160	23	677
BN.126 Pier 2 Wang-0126-BSB-03	698.9	570	0.0	0.0	314	51	649
		473	0.0	0.0	260	43	657
		436	0.0	0.0	240	42	658
		364	0.0	0.0	200	34	666
		291	0.0	0.0	160	33	667

Structure Unit (Reference Boring)	Pile Cap Base Elevations (feet)	Required Nominal Bearing, R_N (kips)	Factored Geotechnical Loss (kips)	Factored Geotechnical Load Loss (kips)	Factored Resistance Available, R_F (kips)	Total Estimated Pile Length (feet)	Estimated Pile Tip Elevation (feet)
BN.126 North Abutment Wang-0126- BSB-03 & Wang-0126- BSB-04	724.1	570	0.0	0.0	314	42	683
		473	0.0	0.0	260	37	688
		436	0.0	0.0	240	35	690
		400	0.0	0.0	220	34	691
		291	0.0	0.0	160	24	701

Table 9: Estimated Pile Lengths and Tip Elevations for 16-inch MSP w/.312-inch walls

Structure Unit (Reference Boring)	Pile Cap Base Elevations (feet)	Required Nominal Bearing, R_N (kips)	Factored Geotechnical Loss (kips)	Factored Geotechnical Load Loss (kips)	Factored Resistance Available, R_F (kips)	Total Estimated Pile Length (feet)	Estimated Pile Tip Elevation (feet)
BN.125 South Abutment Wang-0125- BSB-01 & Wang-0125- BSB-02	723.3	654	0.0	0.0	360	50	674
		618	0.0	0.0	340	50	674
		545	0.0	0.0	300	47	677
		473	0.0	0.0	260	37	687
		400	0.0	0.0	220	33	691
BN.125 Pier 1 Wang-0125- BSB-02	698.9	291	0.0	0.0	160	16	708
		654	0.0	0.0	360	43	657
		582	0.0	0.0	320	40	660
		509	0.0	0.0	280	33	667

Structure Unit (Reference Boring)	Pile Cap Base Elevations (feet)	Required Nominal Bearing, R_N (kips)	Factored Geotechnical Loss (kips)	Factored Geotechnical Load Loss (kips)	Factored Resistance Available, R_F (kips)	Total Estimated Pile Length (feet)	Estimated Pile Tip Elevation (feet)
		436	0.0	0.0	240	27	673
		364	0.0	0.0	200	23	677
		291	0.0	0.0	160	18	682
		654	0.0	0.0	360	51	649
		582	0.0	0.0	320	47	653
BN.125 Pier 2 Wang-0125- BSB-03	698.9	509	0.0	0.0	280	42	658
		436	0.0	0.0	240	40	660
		364	0.0	0.0	200	35	665
		291	0.0	0.0	160	21	679
		654	0.0	0.0	360	37	688
		618	0.0	0.0	340	37	688
BN.125 North Abutment Wang-0125- BSB-03 & Wang-0125- BSB-04	723.7	545	0.0	0.0	300	36	689
		473	0.0	0.0	260	23	702
		400	0.0	0.0	220	19	706
		291	0.0	0.0	160	12	713
BN.126 South Abutment Wang-0126- BSB-01 & Wang-0126- BSB-02	723.3	654	0.0	0.0	360	45	679
		618	0.0	0.0	340	44	680
		545	0.0	0.0	300	41	683

Structure Unit (Reference Boring)	Pile Cap Base Elevations (feet)	Required Nominal Bearing, R_N (kips)	Factored Geotechnical Loss (kips)	Factored Geotechnical Load Loss (kips)	Factored Resistance Available, R_F (kips)	Total Estimated Pile Length (feet)	Estimated Pile Tip Elevation (feet)
		473	0.0	0.0	260	40	684
		400	0.0	0.0	220	39	685
		291	0.0	0.0	160	25	699
		654	0.0	0.0	360	37	663
		582	0.0	0.0	320	36	664
BN.126 Pier 1 Wang-0126-BSB-02	698.9	509	0.0	0.0	280	34	666
		436	0.0	0.0	240	31	669
		364	0.0	0.0	200	23	677
		291	0.0	0.0	160	20	680
		654	0.0	0.0	360	49	651
		582	0.0	0.0	320	42	658
BN.126 Pier 2 Wang-0126-BSB-03	698.9	509	0.0	0.0	280	41	659
		436	0.0	0.0	240	33	667
		364	0.0	0.0	200	32	668
		291	0.0	0.0	160	26	674
BN.126 North Abutment Wang-0126-BSB-03 & Wang-0126-BSB-04	724.1	654	0.0	0.0	360	41	684
		618	0.0	0.0	340	39	686
		545	0.0	0.0	300	36	689

Structure Unit (Reference Boring)	Pile Cap Base Elevations (feet)	Required Nominal Bearing, R_N (kips)	Factored Geotechnical Loss (kips)	Factored Geotechnical Load Loss (kips)	Factored Resistance Available, R_F (kips)	Total Estimated Pile Length (feet)	Estimated Pile Tip Elevation (feet)
		473	0.0	0.0	260	33	692
		400	0.0	0.0	220	29	696
		291	0.0	0.0	160	17	708

Table 10: Estimated Pile Lengths and Tip Elevations for HP12x53 Steel Abutment Piles

Structure Unit (Reference Boring)	Pile Cap Base Elevations (feet)	Required Nominal Bearing, R_N (kips)	Factored Geotechnical Loss (kips)	Factored Geotechnical Load Loss (kips)	Factored Resistance Available, R_F (kips)	Total Estimated Pile Length (feet)	Estimated Pile Tip Elevation (feet)
BN.125 South Abutment Wang-0125- BSB-01& Wang-0125- BSB-02	723.3	418	0.0	0.0	230	93	631
		400	0.0	0.0	220	90	634
		327	0.0	0.0	180	73	651
		255	0.0	0.0	140	68	656
		182	0.0	0.0	100	59	665
		109	0.0	0.0	60	46	678
BN.125 Pier 1 Wang-0125- BSB-02	698.9	418	0.0	0.0	230	86	614
		400	0.0	0.0	220	84	616
		327	0.0	0.0	180	73	627
		255	0.0	0.0	140	60	640
		182	0.0	0.0	100	51	649

Structure Unit (Reference Boring)	Pile Cap Base Elevations (feet)	Required Nominal Bearing, R_N (kips)	Factored Geotechnical Loss (kips)	Factored Geotechnical Load Loss (kips)	Factored Resistance Available, R_F (kips)	Total Estimated Pile Length (feet)	Estimated Pile Tip Elevation (feet)
		109	0.0	0.0	60	43	657
		418	0.0	0.0	230	81	619
		400	0.0	0.0	220	78	622
BN.125 Pier 2 Wang-0125- BSB-03	698.9	364	0.0	0.0	200	76	624
		327	0.0	0.0	180	72	628
		291	0.0	0.0	160	70	630
		418	0.0	0.0	230	85	640
		400	0.0	0.0	220	82	643
BN.125 North Abutment Wang-0125- BSB-03 & Wang-0125- BSB-04	723.7	364	0.0	0.0	200	79	646
		327	0.0	0.0	180	77	648
		291	0.0	0.0	160	65	660
		418	0.0	0.0	230	87	637
		400	0.0	0.0	220	86	638
BN.126 South Abutment Wang-0126- BSB-01 & Wang-0126- BSB-02	723.3	327	0.0	0.0	180	79	645
		255	0.0	0.0	140	71	653
		182	0.0	0.0	100	60	664
		109	0.0	0.0	60	46	678
BN.126 Pier 1	698.9	418	0.0	0.0	230	69	631

Structure Unit (Reference Boring)	Pile Cap Base Elevations (feet)	Required Nominal Bearing, R_N (kips)	Factored Geotechnical Loss (kips)	Factored Geotechnical Load Loss (kips)	Factored Resistance Available, R_F (kips)	Total Estimated Pile Length (feet)	Estimated Pile Tip Elevation (feet)
Wang-0126-BSB-02		400	0.0	0.0	220	69	631
		364	0.0	0.0	200	67	633
		327	0.0	0.0	180	66	634
		291	0.0	0.0	160	64	636
BN.126 Pier 2 Wang-0126-BSB-03	698.9	418	0.0	0.0	230	82	618
		400	0.0	0.0	220	81	619
		364	0.0	0.0	200	77	623
		327	0.0	0.0	180	73	627
		291	0.0	0.0	160	71	629
BN.126 North Abutment Wang-0126-BSB-03 & Wang-0126-BSB-04	724.1	418	0.0	0.0	230	84	641
		400	0.0	0.0	220	82	643
		327	0.0	0.0	180	76	649
		255	0.0	0.0	140	65	660
		182	0.0	0.0	100	54	671
		109	0.0	0.0	60	40	685

Table 11: Estimated Pile Lengths and Tip Elevations for HP12x63 Steel Piles

Structure Unit (Reference Boring)	Pile Cap Base Elevations (feet)	Required Nominal Bearing, R_N (kips)	Factored Geotechnical Loss (kips)	Factored Geotechnical Load Loss (kips)	Factored Resistance Available, R_F (kips)	Total Estimated Pile Length (feet)	Estimated Pile Tip Elevation (feet)
BN.125 South Abutment Wang-0125- BSB-01 & Wang-0125- BSB-02	723.3	497	0	0	273	99	625
		436	0	0	240	94	630
		364	0	0	200	82	642
		291	0	0	160	70	654
		218	0	0	120	62	662
		145	0	0	80	54	670
BN.125 Pier 1 Wang-0125- BSB-02	698.9	497	0	0	273	89	611
		473	0	0	260	86	614
		436	0	0	240	86	614
		400	0	0	220	84	616
		364	0	0	200	77	623
		327	0	0	180	73	627
		291	0	0	160	71	629
BN.125 Pier 2 Wang-0125- BSB-03	698.9	497	0	0	273	94	606
		436	0	0	240	92	608
		364	0	0	200	75	625
		291	0	0	160	69	631

Structure Unit (Reference Boring)	Pile Cap Base Elevations (feet)	Required Nominal Bearing, R_N (kips)	Factored Geotechnical Loss (kips)	Factored Geotechnical Load Loss (kips)	Factored Resistance Available, R_F (kips)	Total Estimated Pile Length (feet)	Estimated Pile Tip Elevation (feet)
		218	0	0	120	65	635
		145	0	0	80	57	643
BN.125 North Abutment Wang-0125- BSB-03 & Wang-0125- BSB-04	723.7	497	0	0	273	86	639
		436	0	0	240	85	640
		364	0	0	200	79	646
		291	0	0	160	65	660
		218	0	0	120	53	672
		145	0	0	80	41	684
BN.126 South Abutment Wang-0126- BSB-01 & Wang-0126- BSB-02	723.3	497	0	0	273	88	636
		436	0	0	240	87	637
		364	0	0	200	82	642
		291	0	0	160	75	649
		218	0	0	120	67	657
		145	0	0	80	51	673
BN.126 Pier 1 Wang-0126- BSB-02	698.9	497	0	0	273	88	612
		473	0	0	260	81	619
		436	0	0	240	75	625
		400	0	0	220	71	629

Structure Unit (Reference Boring)	Pile Cap Base Elevations (feet)	Required Nominal Bearing, R_N (kips)	Factored Geotechnical Loss (kips)	Factored Geotechnical Load Loss (kips)	Factored Resistance Available, R_F (kips)	Total Estimated Pile Length (feet)	Estimated Pile Tip Elevation (feet)
		364	0	0	200	67	633
		291	0	0	160	64	636
BN.126 Pier 2 Wang-0126- BSB-03	698.9	497	0	0	273	94	606
		473	0	0	260	91	609
		436	0	0	240	85	615
		400	0	0	220	80	620
		364	0	0	200	76	624
		291	0	0	160	70	630
BN.126 North Abutment Wang-0126- BSB-03 & Wang-0126- BSB-04	724.1	497	0	0	273	92	633
		436	0	0	240	88	637
		364	0	0	200	78	647
		291	0	0	160	72	653
		218	0	0	120	58	667
		145	0	0	80	48	677

Table 12: Estimated Pile Lengths and Tip Elevations for HP14x73 Steel Piles

Structure Unit (Reference Boring)	Pile Cap Base Elevations (feet)	Required Nominal Bearing, R_N (kips)	Factored Geotechnical Loss (kips)	Factored Geotechnical Load Loss (kips)	Factored Resistance Available, R_F (kips)	Total Estimated Pile Length (feet)	Estimated Pile Tip Elevation (feet)
BN.125 South Abutment Wang-0125- BSB-01 & Wang-0125- BSB-02	723.3	578	0	0	318	97	627
		509	0	0	280	92	632
		436	0	0	240	87	637
		364	0	0	200	71	653
		291	0	0	160	66	658
BN.125 Pier 1 Wang-0125- BSB-02	698.9	578	0	0	318	89	611
		509	0	0	280	86	614
		436	0	0	240	77	623
		364	0	0	200	72	628
		291	0	0	160	56	644
BN.125 Pier 2 Wang-0125- BSB-03	698.9	578	0	0	318	93	607
		509	0	0	280	91	609
		436	0	0	240	73	627
		364	0	0	200	70	630
		291	0	0	160	67	633
BN.125 North Abutment Wang-0125- BSB-03 &	723.7	578	0	0	318	86	639
		509	0	0	280	84	641

Structure Unit (Reference Boring)	Pile Cap Base Elevations (feet)	Required Nominal Bearing, R_N (kips)	Factored Geotechnical Loss (kips)	Factored Geotechnical Load Loss (kips)	Factored Resistance Available, R_F (kips)	Total Estimated Pile Length (feet)	Estimated Pile Tip Elevation (feet)
Wang-0125-BSB-04		436	0	0	240	78	647
		364	0	0	200	66	659
		291	0	0	160	57	668
BN.126 South Abutment Wang-0126-BSB-01 & Wang-0126-BSB-02	723.3	578	0	0	318	88	636
		509	0	0	280	87	637
		436	0	0	240	82	642
		364	0	0	200	76	648
		291	0	0	160	70	654
BN.126 Pier 1 Wang-0126-BSB-02	698.9	578	0	0	318	77	623
		509	0	0	280	73	627
		436	0	0	240	68	632
		364	0	0	200	65	635
		291	0	0	160	62	638
BN.126 Pier 2 Wang-0126-BSB-03	698.9	578	0	0	318	91	609
		509	0	0	280	82	618
		436	0	0	240	77	623
		364	0	0	200	71	629
		291	0	0	160	67	633

Structure Unit (Reference Boring)	Pile Cap Base Elevations (feet)	Required Nominal Bearing, R_N (kips)	Factored Geotechnical Loss (kips)	Factored Geotechnical Load Loss (kips)	Factored Resistance Available, R_F (kips)	Total Estimated Pile Length (feet)	Estimated Pile Tip Elevation (feet)
		578	0	0	318	89	636
BN.126 North Abutment		509	0	0	280	88	637
Wang-0126-BSB-03 & Wang-0126-BSB-04	724.1	436	0	0	240	78	647
		364	0	0	200	73	652
		291	0	0	160	62	663

Table 13: Estimated Pile Lengths and Tip Elevations for HP14x117 Steel Piles

Structure Unit (Reference Boring)	Pile Cap Base Elevations (feet)	Required Nominal Bearing, R_N (kips)	Factored Geotechnical Loss (kips)	Factored Geotechnical Load Loss (kips)	Factored Resistance Available, R_F (kips)	Total Estimated Pile Length (feet)	Estimated Pile Tip Elevation (feet)
		473	0	0	260	88	636
BN.125 South Abutment		400	0	0	220	72	652
Wang-0125-BSB-01 & Wang-0125-BSB-02	723.3	327	0	0	180	68	656
		255	0	0	140	60	664
		182	0	0	100	54	670
		702	0	0	386	93	607
BN.125 Pier 1		691	0	0	380	92	608
Wang-0125-BSB-02	698.9	618	0	0	340	89	611
		545	0	0	300	86	614

Structure Unit (Reference Boring)	Pile Cap Base Elevations (feet)	Required Nominal Bearing, R_N (kips)	Factored Geotechnical Loss (kips)	Factored Geotechnical Load Loss (kips)	Factored Resistance Available, R_F (kips)	Total Estimated Pile Length (feet)	Estimated Pile Tip Elevation (feet)
		473	0	0	260	80	620
		649	0	0	357	94	606
		618	0	0	340	93	607
BN.125 Pier 2 Wang-0125- BSB-03	698.9	545	0	0	300	92	608
		473	0	0	260	75	625
		436	0	0	240	72	628
		618	0	0	340	86	639
		545	0	0	300	84	641
BN.125 North Abutment Wang-0125- BSB-03 & Wang-0125- BSB-04	723.7	473	0	0	260	79	646
		400	0	0	220	74	651
		327	0	0	180	60	665
		255	0	0	140	50	675
		691	0	0	380	90	634
		618	0	0	340	89	635
BN.126 South Abutment Wang-0126- BSB-01 & Wang-0126- BSB-02	723.3	545	0	0	300	87	637
		473	0	0	260	84	640
		400	0	0	220	78	646
		327	0	0	180	71	653

Structure Unit (Reference Boring)	Pile Cap Base Elevations (feet)	Required Nominal Bearing, R_N (kips)	Factored Geotechnical Loss (kips)	Factored Geotechnical Load Loss (kips)	Factored Resistance Available, R_F (kips)	Total Estimated Pile Length (feet)	Estimated Pile Tip Elevation (feet)
BN.126 Pier 1 Wang-0126- BSB-02	698.9	582	0	0	320	83	617
		545	0	0	300	74	626
		509	0	0	280	71	629
		473	0	0	260	68	632
		436	0	0	240	66	634
		400	0	0	220	65	635
BN.126 Pier 2 Wang-0126- BSB-03	698.9	618	0	0	340	92	608
		582	0	0	320	89	611
		545	0	0	300	83	617
		509	0	0	280	81	619
		473	0	0	260	78	622
		436	0	0	240	75	625
BN.126 North Abutment Wang-0126- BSB-03 & Wang-0126- BSB-04	724.1	473	0	0	260	81	644
		436	0	0	240	77	648
		400	0	0	220	74	651
		364	0	0	200	71	654
		327	0	0	180	65	660

5.4.3 Lateral Loading

Lateral loads on the piles should be analyzed for maximum moments and lateral deflections. Recommended lateral soil modulus and strain parameters required for analysis via the p-y curve method are included in Table 14. The front row of piles at the stub abutments will be battered and we estimate there will be no lateral capacity concern. At the piers the piles may be battered of vertical; once the lateral loads are determined, the pile groups should be checked for maximum moments and lateral deflections. Assuming the movement is 0.25 inch or less, the pile group cast within the pile cap can be considered as a fixed-head condition.

Table 14: Recommended Soil Parameters for Lateral Load Analysis

Soil Type (Layer)	Unit Weight, γ (pcf)	Undrained Shear Strength, c_u (psf)	Estimated Friction Angle, Φ ($^\circ$)	Estimated Lateral Soil Modulus Parameter, k (pci)	Estimated Soil Strain Parameter, ϵ_{50} (%)
Loose to M Dense SAND & SA GRAVEL FILL (1)	120	0	32	60	--
Soft to M Stiff SI CLAY LOAM (2)	115	400	0	500	1.0
Loose to M Dense SAND & SA GRAVEL (2)	120	0	32	60	--
Dense to V Dense SAND & SA GRAVEL (3)	125	0	34	120	--
Dense SILT & SILTY LOAM (4)	125	0	34	120	--

5.5 Stage Construction

The traffic along IL 2 will be staged such that the existing northbound bridge will serve Stage 1 traffic, which will then be moved to the new southbound structure for Stage 2. We do not anticipate temporary shoring will be necessary to construct the new abutments or remove the existing abutments to a level below the proposed riprap.

The piers will be constructed within the river. The EWSE shown on the GPE sheets is 714.1 feet and the river depth from the surface to the streambed was approximately 10 to 11 feet. The base of the pier cap will be constructed approximately 3 to 4 feet below the streambed; therefore, the excavations within the river will support up to 15 feet from the base of the excavation to the water surface. Construction of the piers will require the use of cofferdams with sealcoats at the base. The pay item,

Type 2 Cofferdam should be included in the contract and a seal coat with a minimum thickness of at least 5 feet should be anticipated.

6.0 CONSTRUCTION CONSIDERATIONS

6.1 Site Preparation

Vegetation, surface topsoil, and demolition debris should be cleared and stripped where the new structure will be placed. If unstable or unsuitable materials are exposed during excavation, they should be removed and replaced with compacted structural fill as described in Section 6.3.

6.2 Excavation, Dewatering, and Utilities

Excavations should be performed in accordance with local, state, and federal regulations. The potential effect of ground movements upon nearby utilities should be considered during construction. Excavations for the construction of the abutments can be sloped up to 1:2.5 (V:H).

During the subsurface investigation, the groundwater was encountered at elevations near 724 feet within the embankments. Depending on the time of year and seasonal groundwater elevation, dewatering efforts may be necessary. The groundwater is near, or slightly above, the base of the excavation required for the abutment construction; should construction occur during wet seasons, **this groundwater will create caving and running issues during the abutment excavations.** Furthermore, the design high water elevation of the river is higher than the abutment base elevations along the north side of the bridge. Heavy precipitation could result in river water that may flood an open abutment excavation. Water that does accumulate in open excavations by simple seepage or runoff should be immediately removed by sump pump.

6.3 Filling and Backfilling

Fill material used to attain final design elevations should be pre-approved, compacted, cohesive or granular soil conforming to Section 205 (IDOT 2016). The fill material should be free of organic matter and debris and should be placed in lifts and compacted according to the Standard Specification.

Backfill materials for the abutments and piers must be pre-approved by the Resident Engineer. To backfill the abutments, we recommend porous granular material conforming to the requirements specified in the IDOT Recurring Special Provision No. 586, *Granular Backfill for Structures*. Backfill material should be placed and compacted in accordance with the Special Provision.

6.4 Earthwork Operations

The required earthwork can be accomplished with conventional construction equipment. Moisture and traffic will cause deterioration of exposed subgrade soils. Precautions should be taken by the Contractor to prevent water erosion of the exposed subgrade. A compacted subgrade will minimize water runoff erosion.

Earth moving operations should be scheduled to not coincide with excessive cold or wet weather (early spring, late fall or winter). Any soil allowed to freeze or soften due to the standing water should be removed. Wet weather can cause problems with subgrade compaction.

It is recommended that an experienced geotechnical engineer be retained to inspect the exposed subgrade, monitor earthwork operations, and provide material inspection services during the construction phase of this project.

6.5 Pile Installation

The driven piles shall be furnished and installed according to the requirements of IDOT Section 512, *Piling* (2016). Wang recommends performing one test pile at each substructure location. The test piles shall be driven to 110 percent of the nominal required bearing indicated in the tables throughout Sections 5. We do not anticipate the need for pile shoes.

Due to the granular soils with elevated N-values within the top 10 feet below the abutment base elevations, piles for integral abutments will require precoring and backfilling with bentonite. Integral abutment piles should be precored with 30 inch diameter holes for 10 feet below the base of the abutments. These precores will advance through sand and temporary casing will likely be required to ensure an open borehole. After installation of the piles, any casing should be removed and the annular space between the borehole and the pile should be backfilled with bentonite.

7.0 QUALIFICATIONS

The analysis and recommendations submitted in this report are based upon the data obtained from the borings drilled at the locations shown on the boring logs and in Exhibit 3. This report does not reflect any variations that may occur between the borings or elsewhere on the site, variations whose nature and extent may not become evident until the course of construction. In the event that

any changes in the design and/or location of the structure are planned, we should be timely informed so that our recommendations can be adjusted accordingly.

It has been a pleasure to assist HDR Engineering, Inc. and the Illinois Department of Transportation on this project. Please call if there are any questions, or if we can be of further service.

Respectfully Submitted,

WANG ENGINEERING, INC.

Mickey L. Snider, P.E.
Senior Geotechnical Engineer

Corina T. Farez, P.E., P.G.
QC/QA Reviewer

REFERENCES

- AMERICAN ASSOCIATION OF STATE HIGHWAY TRANSPORTATION OFFICIALS (2015) "AASHTO LRFD Bridge Design Specifications." United States Department of Transportation, Washington, D.C.
- BAUER, R.A., CURRY, B.B., GRAESE, A.M., VAIDEN, R.C., SU, W.J., AND HASEK, M.J. (1991) "Geotechnical Properties of Selected Pleistocene, Silurian, and Ordovician Deposits of Northeastern Illinois." *Environmental Geology 139*, Illinois State Geological Survey.
- DOWDING, C.H. (2000) *Construction Vibrations*. Prentice Hall, 610 pp.
- HANSEL, A.K., and JOHNSON, W.H. (1996) "Wedron and Mason Groups: Lithostratigraphic Reclassification of the Wisconsin Episode, Lake Michigan Lobe Area." *ISGS Bulletin 104*. Illinois State Geological Survey, Champaign 116 p.
- IDOT (2009) "All Geotechnical Manual Users Memorandum 09.1 - Seismic Site Class Definition." Illinois Department of Transportation.
- IDOT (2011) "All Geotechnical Manual Users Memorandum 10.2 - Static Method of Estimating Pile Length." Illinois Department of Transportation.
- IDOT (2012) *Bridge Manual*. Illinois Department of Transportation.
- IDOT (2016) *Standard Specifications for Road and Bridge Construction*. Illinois Department of Transportation. 1098 pp.
- ILLINOIS STATE TOLL HIGHWAY AUTHORITY (2015) *ISTHA Structures Design Manual*.
- ILLINOIS STATE TOLL HIGHWAY AUTHORITY (2015) *Embankment Tollway Special Provision*.
- JOHNSON, W.H., and HANSEL, A.K. (1999) "Wisconsin Episode glacial landscape of central Illinois: A product of subglacial deformation process." *Geological Society of America Special Paper 337*, p. 121-135.
- LEETARU, H.E., SARGENT, M.L., AND KOLATA, D.R (2004) *Geologic Atlas of Cook County for Planning Purposes*. ISGS, Champaign, IL
- LEIGHTON, M.M., EKBLAW, G.E., and HORBERG, L. (1948) "Physiographic Divisions of Illinois." *The Journal of Geology*, v. 56. p. 16-33.
- WILLMAN, H.B. (1971) "Summary of the Geology of the Chicago Area." *ISGS Circular C460*. Illinois State Geological Survey, p. 77.
- WOODS, R.W. (1997) "Dynamic Effects of Pile Installations on Adjacent Structures." *National Cooperative Highway Research Program Synthesis 253*. Transportation Research Board.

EXHIBITS

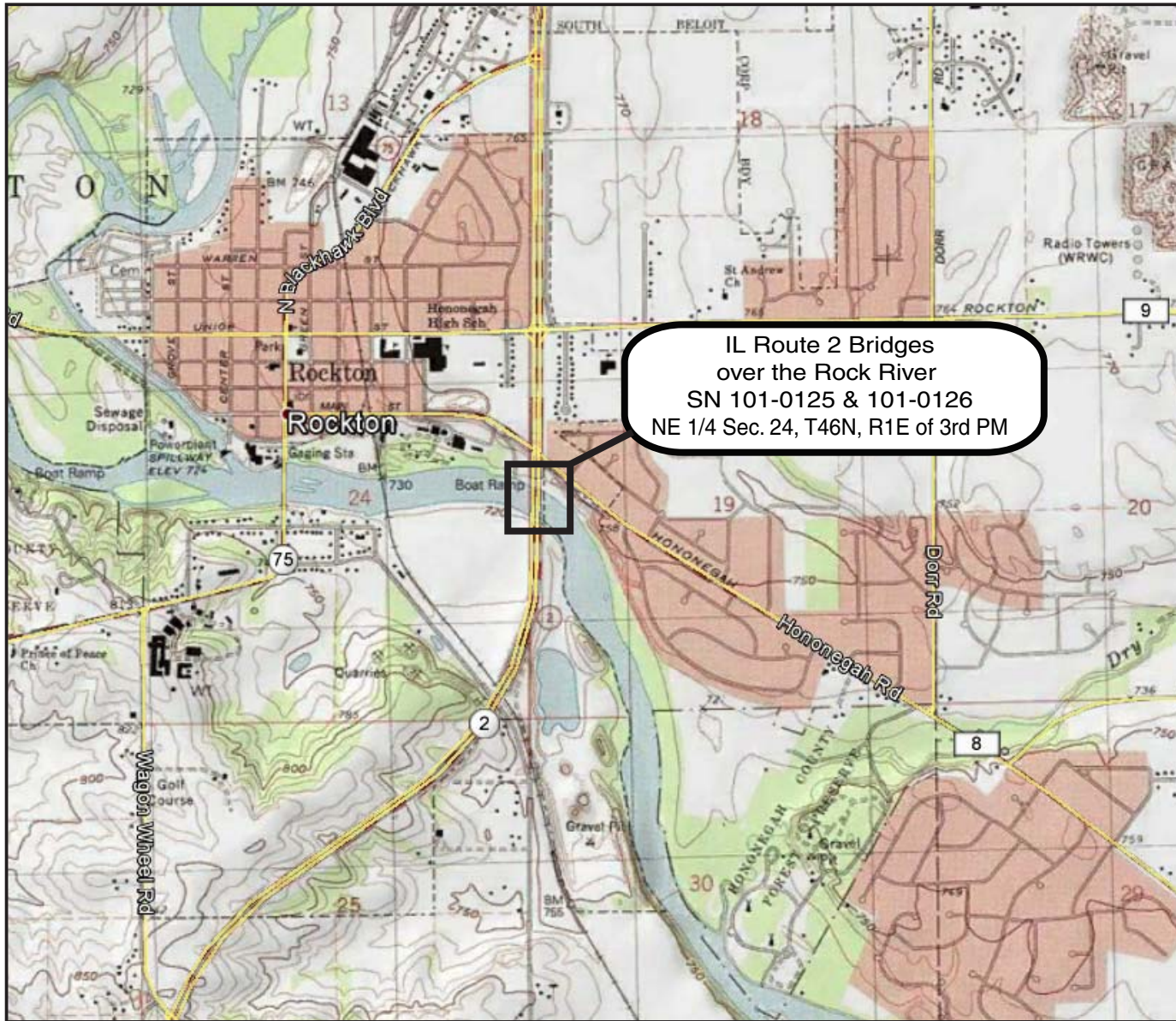

IL Route 2 Bridges
 over the Rock River
 SN 101-0125 & 101-0126
 NE 1/4 Sec. 24, T46N, R1E of 3rd PM

0 0.25 0.50 0.75 1.00 Mile

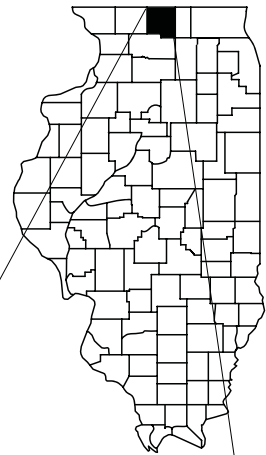

Illinois

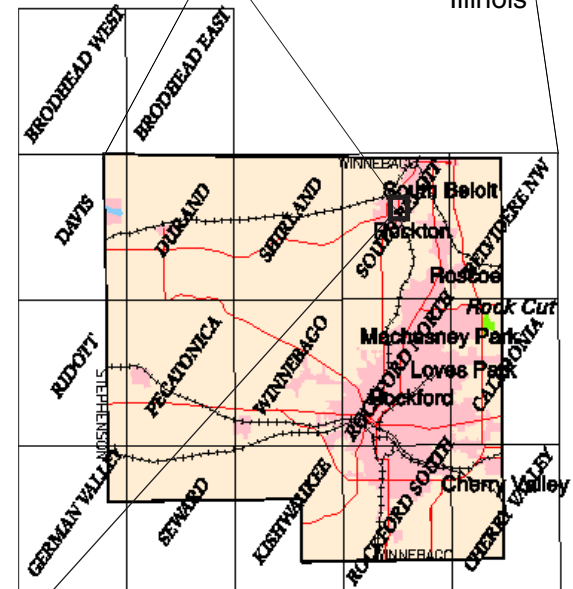

Winnebago County

SITE LOCATION MAP: IL RTE 2 BRIDGES OVER THE ROCK RIVER
 SNs 101-0125 & 101-0126, IDOT D-92-022-15, WINNEBAGO COUNTY

SCALE: GRAPHIC

EXHIBIT 1

DRAWN BY: HKB
 CHECKED BY: CLM



1145 N. Main Street
 Lombard, IL 60148
 www.wangeng.com

FOR HDR ENGINEERING

751-07-01

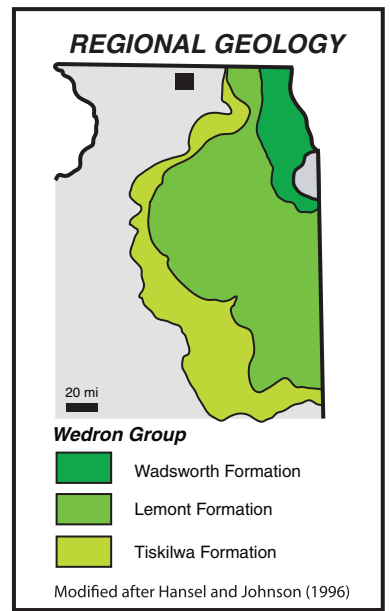
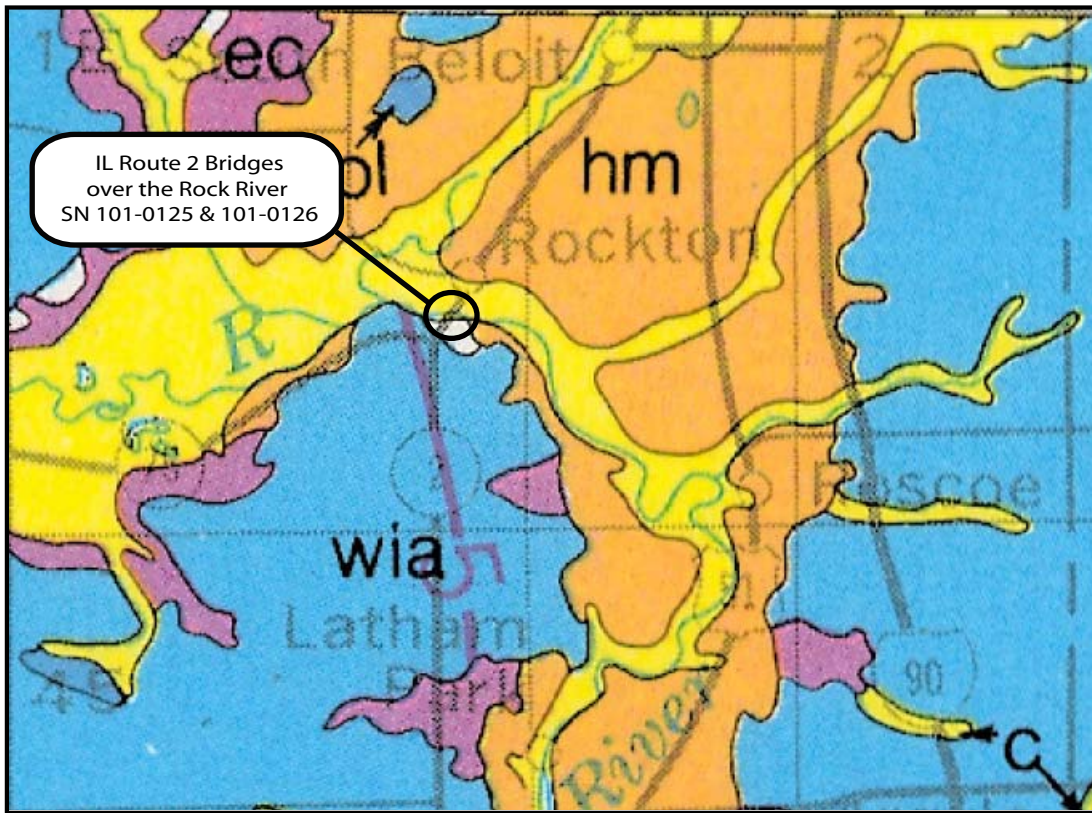

SURFICIAL GEOLOGY

0 1 2 3 Miles **LEGEND** (from Lineback, 1979)

- | | | | |
|--|---|---|---|
| HUDSON EPISODE - (POSTGLACIAL)
(10,000 - 0 years Before Present) | | WISCONSIN EPISODE - MASON GROUP
LAST GLACIATION (55,000 - 10,000 years B.P.) | |
| Cahokia Alluvium,
modern river and floodplain deposits | Equality Member
lake sediments, largely silts and clay | Makinaw Member, Henry Formation,
well sorted sand and gravel glacial outwash deposits in valleys | Argyle Till Member of Winnebago Formation
A very sandy and gravelly pinkish-tan or salmon till |

TOP OF BEDROCK ELEVATION

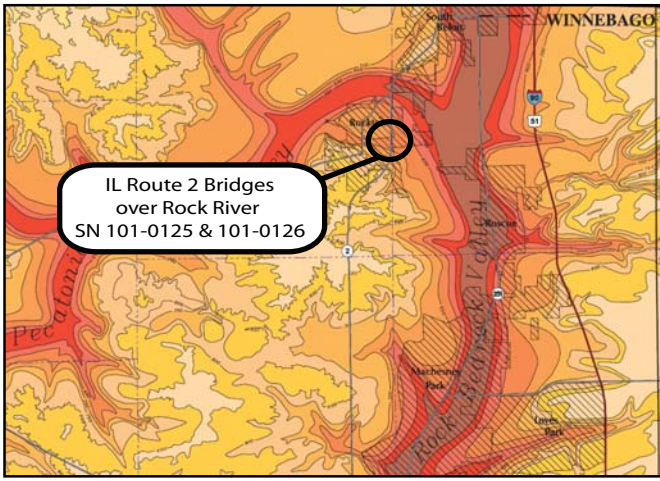

BEDROCK GEOLOGY

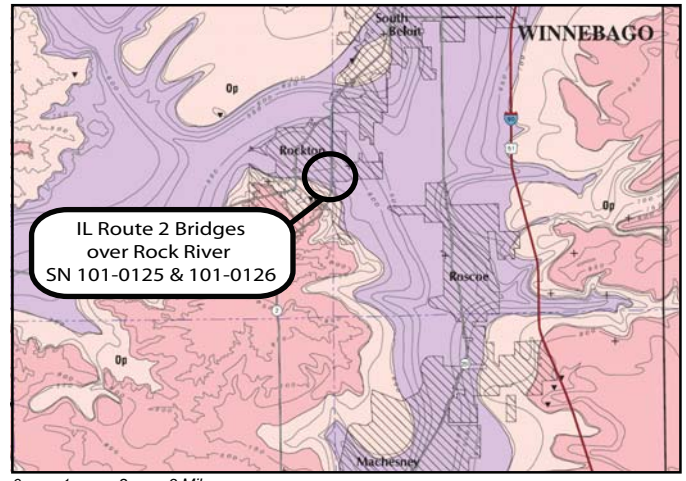

- LEGEND**
Elevations in feet above mean sea level
- | | |
|-----------|---------------|
| 850 - 900 | 600 - 650 |
| 800 - 850 | 550 - 600 |
| 750 - 800 | 500 - 550 |
| 700 - 750 | 450 - 500 |
| 650 - 700 | Less than 450 |

- LEGEND**
- | |
|--|
| Galena Group
Dolomite; brown and gray; coarse grained; primarily pure; 250 feet thick; |
| Plattville Group
Dolomite; brown and gray; fine to very fine grained; 0 to 130 feet thick |
| Ansell Group
Quartz sandstone; white; fine to medium grained; 200 - 400 feet thick |

SITE AND REGIONAL GEOLOGY: IL RTE 2 BRIDGES OVER THE ROCK RIVER
SNs 101-0125 & 101-0126, IDOT D-92-022-15, WINNEBAGO COUNTY

SCALE: GRAPHIC

EXHIBIT 2

DRAWN BY: HKB
CHECKED BY: CLM



1145 N. Main Street
Lombard, IL 60148
www.wangeng.com

FOR HDR ENGINEERING

751-07-01

Bench Mark: #403 Cut "□" on SW corner of North Bound bridge over Rock River, Elev. = 737.0222 (NAVD 88). NAVD 88 = NGVD 29 - 0.187 ft.

Existing Structure: S.N. 101-0125 (SB) & S.N. 101-0126 (NB) Built in 1965 as F.A. Rte. 2 (S.B.I. 2) Section 77-1B, at Sta. 195+19.14. Existing dual structures each consists of 5 continuous spans (99'-6", 119'-6", 119'-6", 119'-6", 99'-6") of 7" reinf. concrete deck with 2" microsilica overlay (added in 1991) on 21" steel WF floor beams and 84" steel plate girders supported by spill-thru pile bent vaulted abutments and solid piers on pile supported spread footings, 563'-0" Bk. to Bk. abutments and 36'-0" Out to Out of each deck. Structure to be removed and replaced. Bridge to be closed and traffic detoured via crossovers.

No salvage.

BORING LOCATION PLAN: IL RTE 2 BRIDGES OVER THE ROCK RIVER
SNs 101-0125 & 101-0126, IDOT D-92-022-15, WINNEBAGO COUNTY

SCALE: GRAPHICAL **EXHIBIT 3** DRAWN BY: RKC
 CHECKED BY: N. Balakumaran

Wang Engineering
 1145 N. Main Street
 Lombard, IL 60148
 www.wangeng.com

FOR HDR ENGINEERING **751-07-01**

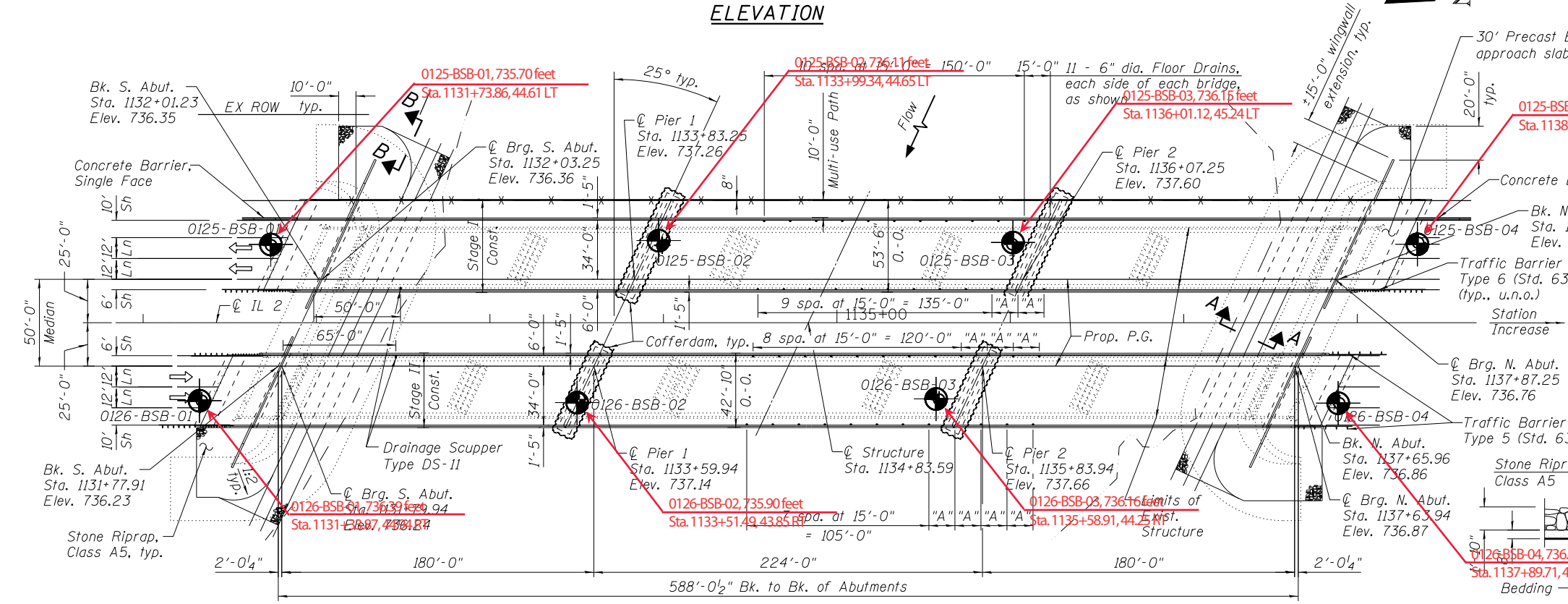
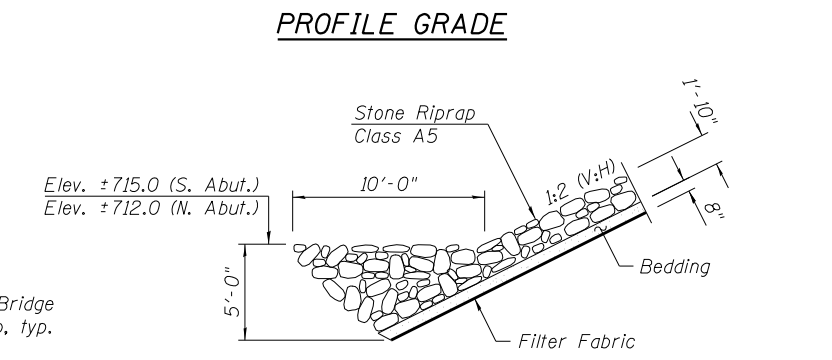
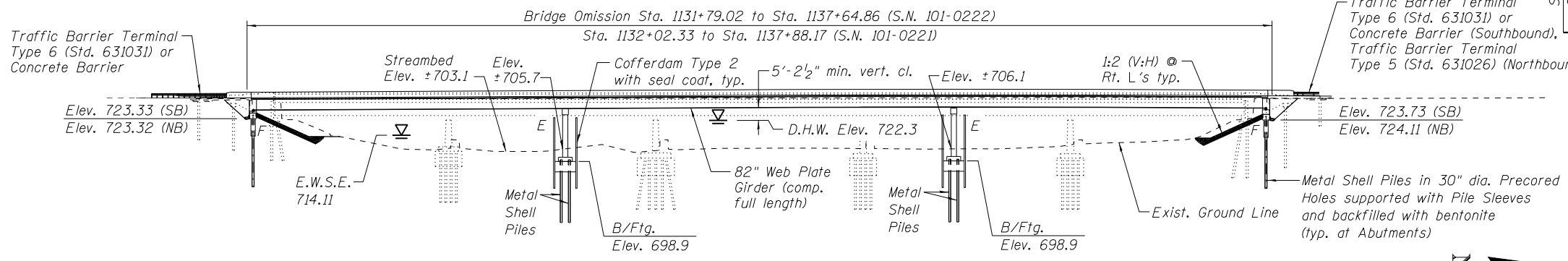
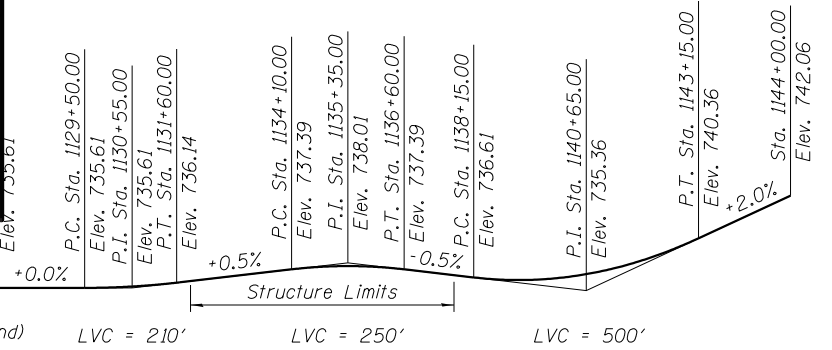

DESIGN STRESSES
FIELD UNITS
 f'c = 3,500 psi
 f'c = 4,000 psi (Superstructure Concrete)
 fy = 60,000 psi (Reinforcement)
 fy = 50,000 psi (M270 Grade 50)

SEISMIC DATA
 Seismic Performance Zone (SPZ) = 1
 Design Spectral Acceleration at 1.0 sec. (SD1) = 0.075g
 Design Spectral Acceleration at 0.2 sec. (SD5) = 0.122g
 Soil Site Class = D

LOADING HL-93
 Allow 50#/sq. ft. for future wearing surface.

DESIGN SPECIFICATIONS
 2020 AASHTO LRFD Bridge Design Specifications, 9th Edition

HIGHWAY CLASSIFICATION
 F.A.P. 734 - IL Rte. 2
 Functional Class: Other Principal Arterial
 ADT: 4,000 (2020) 4,750 (2040) (Each Way)
 ADTT: 187 (2020) 221 (2040) (Each Way)
 DHV: 475 (Each Way)
 Design Speed: 70 m.p.h.
 Posted Speed: 55 m.p.h.

WATERWAY INFORMATION

Existing Overtopping Elev. 735.4 @ Sta. 1137+35
 Drainage Area = 6360 sq. mi. Proposed Overtopping Elev. 733.8 @ Sta. 1139+50

Flood Event	Freq. Yr.	Q	Opening Sq. Ft.		Nat. H.W.E.	Head - Ft.		Headwater El.	
			Exist.	Prop.		Exist.	Prop.	Exist.	Prop.
Design	10	25000	6808	6858	720.4	0.3	0.3	720.7	720.7
Base	50	33300	7786	7863	722.3	0.4	0.4	722.7	722.7
Scour Check	100	36600	8146	8243	723.0	0.4	0.4	723.4	723.4
Max. Calc.	200	39772	8535	8564	723.7	0.5	0.4	724.2	724.1
	500	44000	9024	9116	724.6	0.5	0.5	725.1	725.1

10 Year Velocity Through Existing Bridge = 3.7 ft/s
 10 Year Velocity Through Proposed Bridge = 3.6 ft/s

DESIGN SCOUR ELEVATION TABLE

IL 2 (SB)

Event / Limit	Design Scour Elevations (ft.)				Item 113
	S. Abut.	Pier 1	Pier 2	N. Abut.	
Q100	723.33	696.42	696.41	723.73	5
Q200	723.33	696.37	696.36	723.73	
Design	723.33	696.42	696.41	723.73	
Check	723.33	696.37	696.36	723.73	

IL 2 (NB)

Event / Limit	Design Scour Elevations (ft.)				Item 113
	S. Abut.	Pier 1	Pier 2	N. Abut.	
Q100	723.32	696.60	696.55	724.11	5
Q200	723.32	696.49	696.44	724.11	
Design	723.32	696.60	696.55	724.11	
Check	723.32	696.49	696.44	724.11	

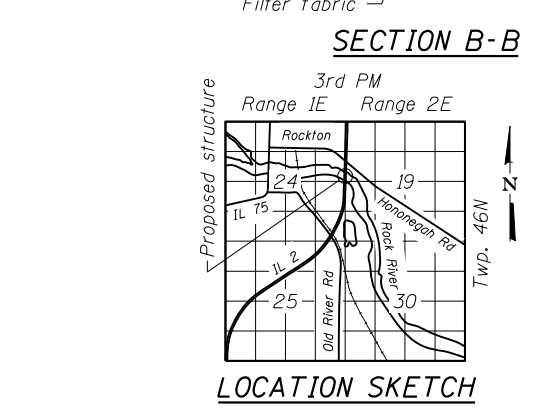

GENERAL PLAN
IL 2 OVER ROCK RIVER
PUBLIC WATERS
F.A.P. 734 (IL RTE. 2) - SEC. 77-1BR
WINNEBAGO COUNTY
STATION 1134+83.59
STRUCTURE NO. 101-0221 (S.B.)
STRUCTURE NO. 101-0222 (N.B.)

c:\pwworking\homa\d289834\101XXXX-101XXXX-TSL-01.dgn
 bsayers
 2/3/2021
 8:19:06 AM

HDR USER NAME = bsayers DESIGNED - RGB REVISED - STATE OF ILLINOIS DEPARTMENT OF TRANSPORTATION F.A.U. RTE. 734 SECTION 77-1BR COUNTY WINNEBAGO TOTAL SHEETS SHEET NO. 1 OF 2 SHEETS

FILE NAME = 101XXXX-101XXXX-TSL-01.DGN CHECKED - JLP REVISED - CONTRACT NO. ILLINOIS FED. AID PROJECT

PLOT SCALE = NONE DRAWN - JM REVISED - SHEET NO. 1 OF 2 SHEETS

PLOT DATE = 2/3/2021 CHECKED - JLP REVISED -

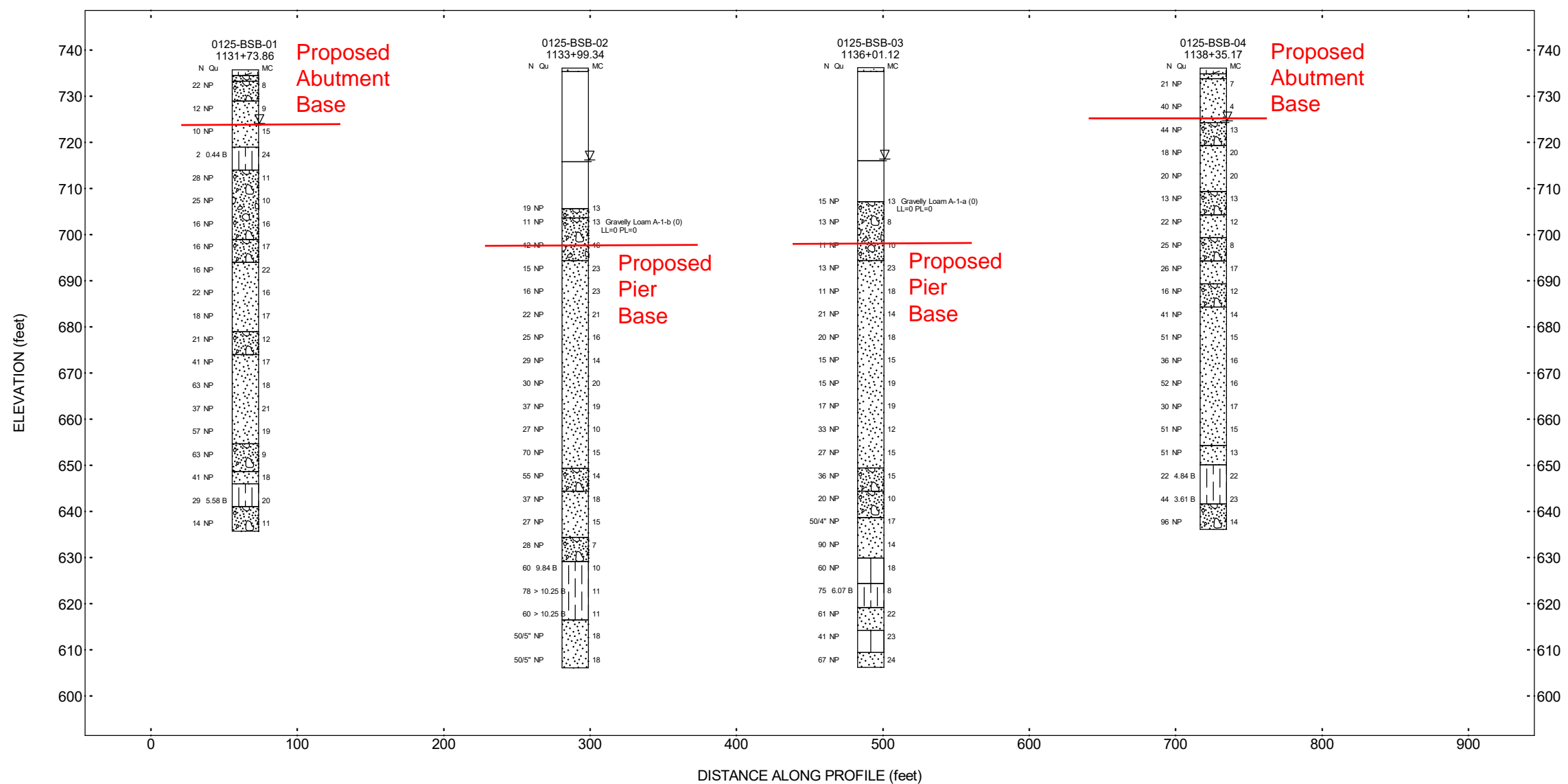
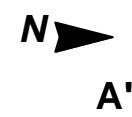
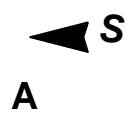

Lithology Graphics

- | | | | |
|----------|-----------------------------|----------------------|---------------------------------|
| Pavement | Gravelly sand, sandy gravel | IDH Sand, Sandy Loam | IDH Silty Clay, Silty Clay Loam |
| Concrete | | IDH Silt, Silty Loam | Crushed stone |

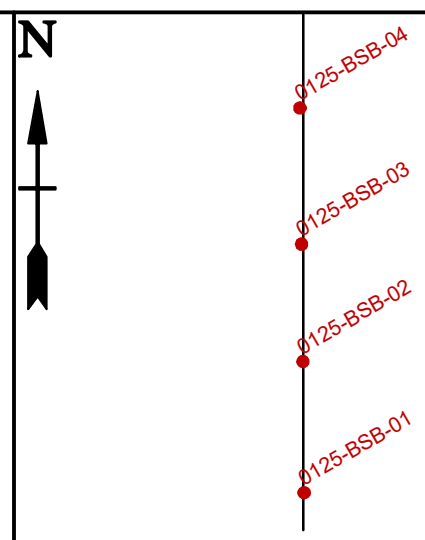

Site Map Scale 1 inch equals 330 feet

Explanation:

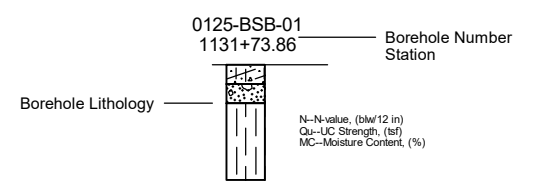

- Water Level Reading at time of drilling.
- Water Level Reading 24-hr after drilling or at end of drilling.

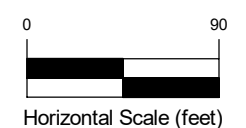

Vertical Exaggeration: 3x

Wang Engineering, Inc.
1145 N Main Street
Lombard, IL 60148

Soil Profile A-A'
Southbound IL2 Bridge
EX SN 101-0125



Illinois Route 2 Bridges over the Rock River Rockton, Winnebago County, Illinois	
JOB NUMBER	PLATE NUMBER
751-07-01	EXHIBIT 4-1

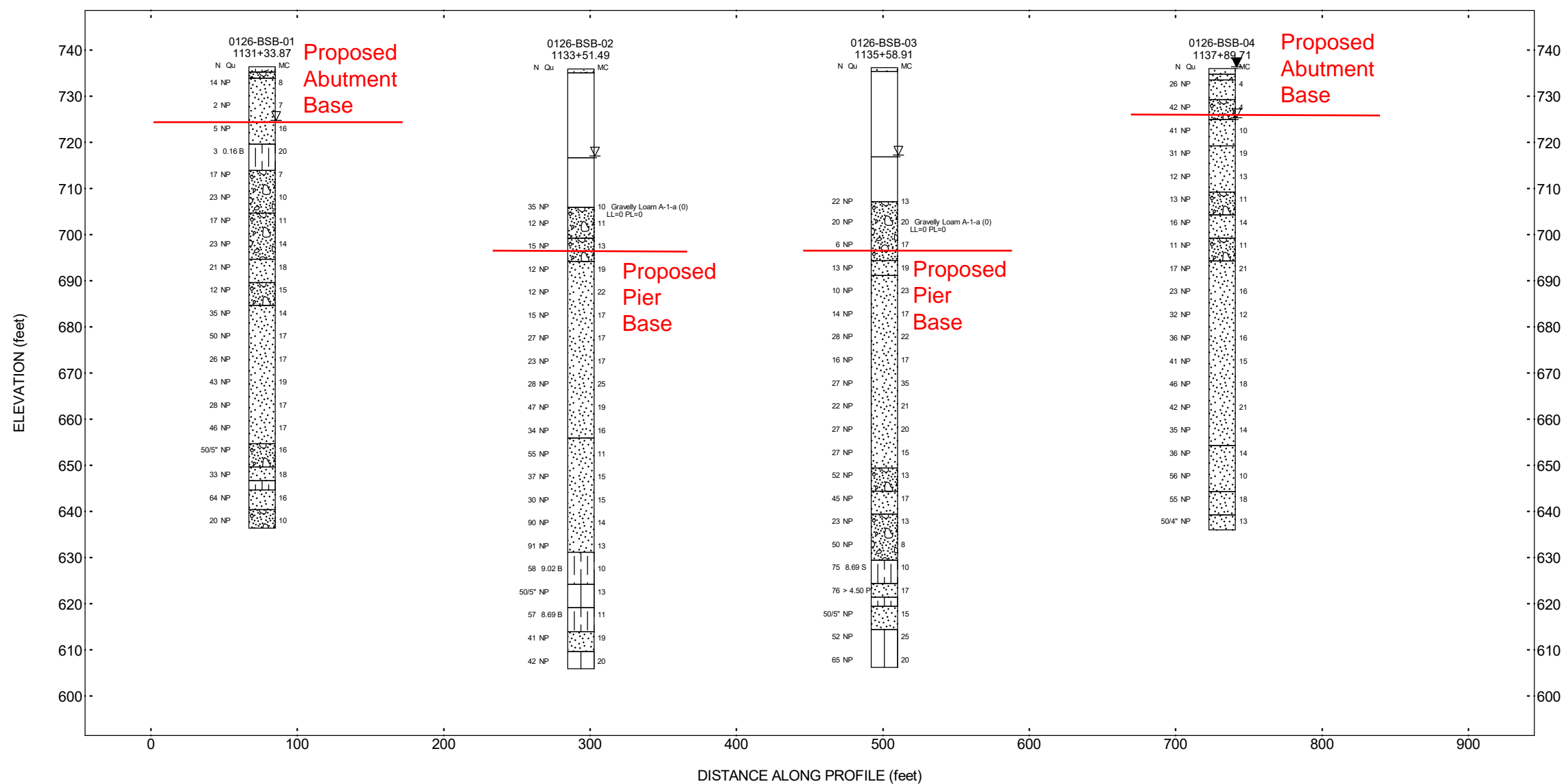
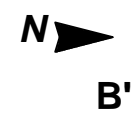
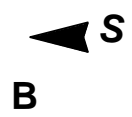

Lithology Graphics

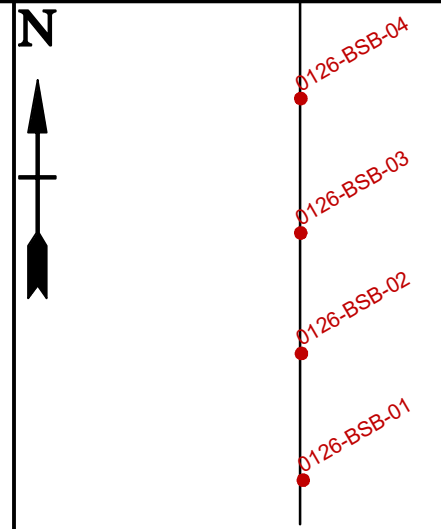
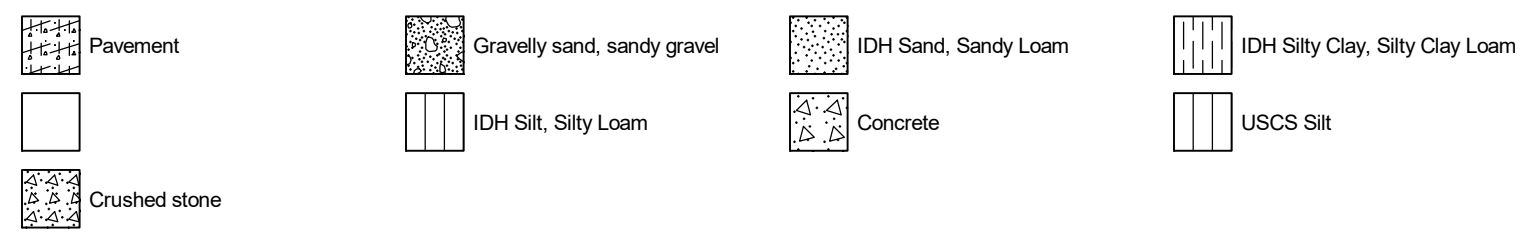

Site Map Scale 1 inch equals 330 feet

Explanation:

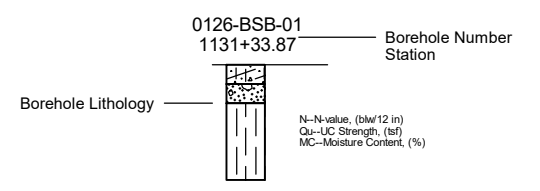

- Water Level Reading at time of drilling.
- Water Level Reading 24-hr after drilling or at end of drilling

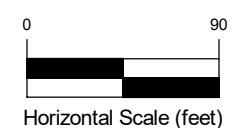

Vertical Exaggeration: 3x

Wang Engineering, Inc.
1145 N Main Street
Lombard, IL 60148

Soil Profile B-B'
Northbound IL2 Bridge
EX SN 101-0126



Illinois Route 2 Bridges over the Rock River
Rockton, Winnebago County, Illinois

JOB NUMBER	PLATE NUMBER
751-07-01	EXHIBIT 4-2

APPENDIX A



wangeng@wangeng.com
 1145 N Main Street
 Lombard, IL 60148
 Telephone: (630) 953-9928
 Fax:

BORING LOG 0125-BSB-01

WEI Job No.: 751-07-01

Client **HDR Engineering, Inc.**
 Project **Illinois Route 2 Bridges over the Rock River**
 Location **Rockton, Winnebago County, Illinois**

Datum: NAVD 88
 Elevation: 735.70 ft
 North: 2107880.30 ft
 East: 2595316.12 ft
 Station: 1131+73.86
 Offset: 44.61 LT

Profile	Elevation (ft)	SOIL AND ROCK DESCRIPTION	Depth (ft)	Sample Type recovery	Sample No.	SPT Values (blw/6 in)	Qu (tsf)	Moisture Content (%)	Profile	Elevation (ft)	SOIL AND ROCK DESCRIPTION	Depth (ft)	Sample Type recovery	Sample No.	SPT Values (blw/6 in)	Qu (tsf)	Moisture Content (%)
	734.5	2.75-inch ASPHALT over 12-inch thick CONCRETE --PAVEMENT--								714.0							
	733.2	Brown CRUSHED STONE --AGGREGATE BASE--									Medium dense, brown SANDY GRAVEL; saturated --RDR 2 to 3--						
		Medium dense, brown SANDY GRAVEL; damp --FILL-- --RDR 2--	5		1	4 10 12	NP	8				25		5	4 11 17	NP	11
	729.0	Medium dense, dark brown, medium to coarse SAND; moist --FILL-- --RDR 2--	10		2	6 6 6	NP	9				30		6	10 12 13	NP	10
			15		3	5 5 5	NP	15				35		7	14 9 7	NP	16
	719.0	Soft, dark brown SILTY CLAY LOAM, trace organic matter --RDR 1--	20		4	0 0 2	0.44 B	24		699.0	Medium dense, brown GRAVELLY SAND; saturated --RDR 2--	40		8	8 8 8	NP	17

GENERAL NOTES

WATER LEVEL DATA

Begin Drilling **10-30-2019** Complete Drilling **10-30-2019**
 Drilling Contractor **Wang Testing Services** Drill Rig
 Driller **RR&JD** Logger **F. Bozga** Checked by **M. Snider**
 Drilling Method **2.25" IDA HSA to 10'; mud rotary thereafter;**
autohammer, boring backfilled upon completion

While Drilling **12.00 ft**
 At Completion of Drilling **12' Mud**
 Time After Drilling **NA**
 Depth to Water **NA**

The stratification lines represent the approximate boundary between soil types; the actual transition may be gradual.

WANGENG 7510701.GPJ WANGENG.GDT 12/18/19



wangeng@wangeng.com
 1145 N Main Street
 Lombard, IL 60148
 Telephone: (630) 953-9928
 Fax:

BORING LOG 0125-BSB-01

WEI Job No.: 751-07-01

Client **HDR Engineering, Inc.**
 Project **Illinois Route 2 Bridges over the Rock River**
 Location **Rockton, Winnebago County, Illinois**

Datum: NAVD 88
 Elevation: 735.70 ft
 North: 2107880.30 ft
 East: 2595316.12 ft
 Station: 1131+73.86
 Offset: 44.61 LT

Profile	Elevation (ft)	SOIL AND ROCK DESCRIPTION	Depth (ft)	Sample Type recovery	Sample No.	SPT Values (blw/6 in)	Qu (tsf)	Moisture Content (%)	Profile	Elevation (ft)	SOIL AND ROCK DESCRIPTION	Depth (ft)	Sample Type recovery	Sample No.	SPT Values (blw/6 in)	Qu (tsf)	Moisture Content (%)
	694.0									674.0							
		Medium dense, brown, medium to coarse SAND; wet --RDR 2--	45	X	9	7 8 8	NP	22			Dense to very dense, brown, medium to coarse SAND; wet --RDR 2--	65	X	13	12 14 27	NP	17
			50	X	10	9 11 11	NP	16			--fine to medium--	70	X	14	16 23 40	NP	18
			55	X	11	8 8 10	NP	17			--fine--	75	X	15	13 15 22	NP	21
	679.0	Medium dense, brown GRAVELLY SAND; wet --RDR 2--	60	X	12	10 10 11	NP	12				80	X	16	16 25 32	NP	19

GENERAL NOTES

WATER LEVEL DATA

Begin Drilling **10-30-2019** Complete Drilling **10-30-2019**
 Drilling Contractor **Wang Testing Services** Drill Rig
 Driller **RR&JD** Logger **F. Bozga** Checked by **M. Snider**
 Drilling Method **2.25" IDA HSA to 10'; mud rotary thereafter;**
autohammer, boring backfilled upon completion

While Drilling ∇ **12.00 ft**
 At Completion of Drilling ∇ **12' Mud**
 Time After Drilling **NA**
 Depth to Water ∇ **NA**

The stratification lines represent the approximate boundary between soil types; the actual transition may be gradual.

WANGENG 7510701.GPJ WANGENG.GDT 12/18/19



wangeng@wangeng.com
 1145 N Main Street
 Lombard, IL 60148
 Telephone: (630) 953-9928
 Fax:

BORING LOG 0125-BSB-01

WEI Job No.: 751-07-01

Client **HDR Engineering, Inc.**
 Project **Illinois Route 2 Bridges over the Rock River**
 Location **Rockton, Winnebago County, Illinois**

Datum: NAVD 88
 Elevation: 735.70 ft
 North: 2107880.30 ft
 East: 2595316.12 ft
 Station: 1131+73.86
 Offset: 44.61 LT

Profile	Elevation (ft)	SOIL AND ROCK DESCRIPTION	Depth (ft)	Sample Type recovery	Sample No.	SPT Values (blw/6 in)	Qu (tsf)	Moisture Content (%)	Profile	Elevation (ft)	SOIL AND ROCK DESCRIPTION	Depth (ft)	Sample Type recovery	Sample No.	SPT Values (blw/6 in)	Qu (tsf)	Moisture Content (%)
	654.7	--rig chatter, 81 to 83 feet-- Very dense, brown SANDY GRAVEL; wet --RDR 3 to 4--	85		17	30 28 35	NP	9									
	648.7	Dense, brown, medium SAND; wet --RDR 2--	90		18	17 19 22	NP	18									
	646.0	Hard, pinkish gray SILTY CLAY, trace gravel --RDR 2 to 3-- rig chatter; possible cobble--	95		19	10 11 18	5.58 B	20									
	641.0	Medium dense, brown SANDY GRAVEL; wet --RDR 2-- --occasional rig chatter--	100		20	11 6 8	NP	11									
	635.7	Boring terminated at 100.00 ft															

GENERAL NOTES

Begin Drilling **10-30-2019** Complete Drilling **10-30-2019**
 Drilling Contractor **Wang Testing Services** Drill Rig
 Driller **RR&JD** Logger **F. Bozga** Checked by **M. Snider**
 Drilling Method **2.25" IDA HSA to 10'; mud rotary thereafter;**
autohammer, boring backfilled upon completion

WATER LEVEL DATA

While Drilling ∇ **12.00 ft**
 At Completion of Drilling ∇ **12' Mud**
 Time After Drilling **NA**
 Depth to Water ∇ **NA**

The stratification lines represent the approximate boundary between soil types; the actual transition may be gradual.

WANGENGINC 7510701.GPJ WANGENG.GDT 12/18/19



wangeng@wangeng.com
 1145 N Main Street
 Lombard, IL 60148
 Telephone: (630) 953-9928
 Fax:

BORING LOG 0125-BSB-02

WEI Job No.: 751-07-01

Client **HDR Engineering, Inc.**
 Project **Illinois Route 2 Bridges over the Rock River**
 Location **Rockton, Winnebago County, Illinois**

Datum: NAVD 88
 Elevation: 736.11 ft
 North: 2108105.77 ft
 East: 2595314.13 ft
 Station: 1133+99.34
 Offset: 44.65 LT

Profile	Elevation (ft)	SOIL AND ROCK DESCRIPTION	Depth (ft)	Sample Type recovery	Sample No.	SPT Values (blw/6 in)	Qu (tsf)	Moisture Content (%)	Profile	Elevation (ft)	SOIL AND ROCK DESCRIPTION	Depth (ft)	Sample Type recovery	Sample No.	SPT Values (blw/6 in)	Qu (tsf)	Moisture Content (%)
	735.3	9.75-inch thick CONCRETE --BRIDGE DECK-- --clearance to water level, approx. 20 feet--								715.8	--Rock River--						
			5														
			10							705.6	Medium dense, brown SANDY GRAVEL; saturated --RDR 2--		1	12 9 10		NP	13
			15							703.6	Medium dense, brown, coarse GRAVELLY SAND; saturated --RDR 2-- --% Gravel = 24.6%-- --% Sand = 72.0%-- --% Silt and Clay = 3.4%--		2	6 5 6		NP	13
			20										3	7 6 6		NP	16

GENERAL NOTES

Begin Drilling **11-20-2019** Complete Drilling **11-21-2019**
 Drilling Contractor **Wang Testing Services** Drill Rig
 Driller **R&J&K** Logger **F. Bozga** Checked by **M. Snider**
 Drilling Method **2.25" ID HSA to 30'; mud rotary thereafter;**
autohammer, boring backfilled upon completion

WATER LEVEL DATA

While Drilling **20.33 ft**
 At Completion of Drilling **River**
 Time After Drilling **NA**
 Depth to Water **NA**

The stratification lines represent the approximate boundary between soil types; the actual transition may be gradual.



wangeng@wangeng.com
 1145 N Main Street
 Lombard, IL 60148
 Telephone: (630) 953-9928
 Fax:

BORING LOG 0125-BSB-02

WEI Job No.: 751-07-01

Client **HDR Engineering, Inc.**
 Project **Illinois Route 2 Bridges over the Rock River**
 Location **Rockton, Winnebago County, Illinois**

Datum: NAVD 88
 Elevation: 736.11 ft
 North: 2108105.77 ft
 East: 2595314.13 ft
 Station: 1133+99.34
 Offset: 44.65 LT

Profile	Elevation (ft)	SOIL AND ROCK DESCRIPTION	Depth (ft)	Sample Type recovery	Sample No.	SPT Values (blw/6 in)	Qu (tsf)	Moisture Content (%)	Profile	Elevation (ft)	SOIL AND ROCK DESCRIPTION	Depth (ft)	Sample Type recovery	Sample No.	SPT Values (blw/6 in)	Qu (tsf)	Moisture Content (%)
	634.4	Medium dense, brown SANDY GRAVEL; wet --RDR 2--	85	X	12	16 28 42	NP	15		634.4	Medium dense, brown SANDY GRAVEL; wet --RDR 2--	105	X	16	18 16 12	NP	7
	649.4	Very dense, coarse GRAVELLY SAND; wet --RDR 2--	90	X	13	18 29 26	NP	14		629.1	Hard, pinkish gray SILTY CLAY LOAM --RDR 2--	110	X	17	15 25 35	9.84 B	10
	644.4	Medium dense to dense, brown, very fine to fine SAND; wet --RDR 2--	95	X	14	12 17 20	NP	18				115	X	18	22 33 45	10.25 B	11
			100	X	15	13 14 13	NP	15		616.5	Very dense, gray, fine SAND; wet	20	X	19	17 23 37	10.25 B	11

GENERAL NOTES

WATER LEVEL DATA

Begin Drilling **11-20-2019** Complete Drilling **11-21-2019**
 Drilling Contractor **Wang Testing Services** Drill Rig
 Driller **R&J&K** Logger **F. Bozga** Checked by **M. Snider**
 Drilling Method **2.25" ID HSA to 30'; mud rotary thereafter;**
autohammer, boring backfilled upon completion

While Drilling ∇ **20.33 ft**
 At Completion of Drilling ∇ **River**
 Time After Drilling **NA**
 Depth to Water ∇ **NA**

The stratification lines represent the approximate boundary between soil types; the actual transition may be gradual.

WANGENGINC 7510701.GPJ WANGENG.GDT 12/18/19



BORING LOG 0125-BSB-02

wangeng@wangeng.com
 1145 N Main Street
 Lombard, IL 60148
 Telephone: (630) 953-9928
 Fax:

WEI Job No.: 751-07-01

Client **HDR Engineering, Inc.**
 Project **Illinois Route 2 Bridges over the Rock River**
 Location **Rockton, Winnebago County, Illinois**

Datum: NAVD 88
 Elevation: 736.11 ft
 North: 2108105.77 ft
 East: 2595314.13 ft
 Station: 1133+99.34
 Offset: 44.65 LT

Profile	Elevation (ft)	SOIL AND ROCK DESCRIPTION	Depth (ft)	Sample Type recovery	Sample No.	SPT Values (blw/6 in)	Qu (tsf)	Moisture Content (%)	Profile	Elevation (ft)	SOIL AND ROCK DESCRIPTION	Depth (ft)	Sample Type recovery	Sample No.	SPT Values (blw/6 in)	Qu (tsf)	Moisture Content (%)
		to saturated															
		--RDR 2--															
			125		20	38 50/5"	NP	18									
	606.1		130		21	27 40 50/5"	NP	18									
		Boring terminated at 130.00 ft															
			135														
			140														

GENERAL NOTES

Begin Drilling **11-20-2019** Complete Drilling **11-21-2019**
 Drilling Contractor **Wang Testing Services** Drill Rig
 Driller **R&J&K** Logger **F. Bozga** Checked by **M. Snider**
 Drilling Method **2.25" ID HSA to 30'; mud rotary thereafter;**
autohammer, boring backfilled upon completion

WATER LEVEL DATA

While Drilling ∇ **20.33 ft**
 At Completion of Drilling ∇ **River**
 Time After Drilling **NA**
 Depth to Water ∇ **NA**

The stratification lines represent the approximate boundary between soil types; the actual transition may be gradual.

WANGENGINC 7510701.GPJ WANGENG.GDT 12/18/19



wangeng@wangeng.com
 1145 N Main Street
 Lombard, IL 60148
 Telephone: (630) 953-9928
 Fax:

BORING LOG 0125-BSB-03

WEI Job No.: 751-07-01

Client: **HDR Engineering, Inc.**
 Project: **Illinois Route 2 Bridges over the Rock River**
 Location: **Rockton, Winnebago County, Illinois**

Datum: NAVD 88
 Elevation: 736.15 ft
 North: 2108307.54 ft
 East: 2595311.80 ft
 Station: 1136+01.12
 Offset: 45.24 LT

Profile	Elevation (ft)	SOIL AND ROCK DESCRIPTION	Depth (ft)	Sample Type recovery	Sample No.	SPT Values (blw/6 in)	Qu (tsf)	Moisture Content (%)	Profile	Elevation (ft)	SOIL AND ROCK DESCRIPTION	Depth (ft)	Sample Type recovery	Sample No.	SPT Values (blw/6 in)	Qu (tsf)	Moisture Content (%)
	735.4	10-inch thick CONCRETE --BRIDGE DECK-- --clearance to water level, approx. 20 feet--								716.0	--Rock River--						
			5														
			10							707.2	Medium dense, brown SANDY GRAVEL; saturated --RDR 2-- --% Gravel = 62.1%-- --% Sand = 31.4%-- --% Silt and Clay = 3.8%--	30	1	4 7 8	NP	13	
			15									35	2	9 8 5	NP	8	
			20									40	3	10 5 6	NP	10	

GENERAL NOTES

Begin Drilling **11-19-2019** Complete Drilling **11-20-2019**
 Drilling Contractor **Wang Testing Services** Drill Rig
 Driller **R&J&K** Logger **F. Bozga** Checked by **M. Snider**
 Drilling Method **2.25" ID HSA to 30'; mud rotary thereafter;**
autohammer, boring backfilled upon completion

WATER LEVEL DATA

While Drilling **20.20 ft**
 At Completion of Drilling **River**
 Time After Drilling **NA**
 Depth to Water **NA**
 The stratification lines represent the approximate boundary between soil types; the actual transition may be gradual.

WANGENGINC 7510701.GPJ WANGENG.GDT 12/18/19



BORING LOG 0125-BSB-03

wangeng@wangeng.com
 1145 N Main Street
 Lombard, IL 60148
 Telephone: (630) 953-9928
 Fax:

WEI Job No.: 751-07-01

Client **HDR Engineering, Inc.**
 Project **Illinois Route 2 Bridges over the Rock River**
 Location **Rockton, Winnebago County, Illinois**

Datum: NAVD 88
 Elevation: 736.15 ft
 North: 2108307.54 ft
 East: 2595311.80 ft
 Station: 1136+01.12
 Offset: 45.24 LT

Profile	Elevation (ft)	SOIL AND ROCK DESCRIPTION	Depth (ft)	Sample Type recovery	Sample No.	SPT Values (blw/6 in)	Qu (tsf)	Moisture Content (%)	Profile	Elevation (ft)	SOIL AND ROCK DESCRIPTION	Depth (ft)	Sample Type recovery	Sample No.	SPT Values (blw/6 in)	Qu (tsf)	Moisture Content (%)
	694.4																
		Medium dense to dense, brown, fine to coarse SAND; wet to saturated --RDR 2--															
			45		4	7 6 7	NP	23			--little gravel--	65		8	5 6 9	NP	15
			50		5	5 5 6	NP	18				70		9	5 6 9	NP	19
			55		6	7 9 12	NP	14				75		10	7 8 9	NP	19
			60		7	7 9 11	NP	18			--trace gravel--	80		11	13 16 17	NP	12

GENERAL NOTES

WATER LEVEL DATA

Begin Drilling **11-19-2019** Complete Drilling **11-20-2019**
 Drilling Contractor **Wang Testing Services** Drill Rig
 Driller **R&J&K** Logger **F. Bozga** Checked by **M. Snider**
 Drilling Method **2.25" ID HSA to 30'; mud rotary thereafter;**
autohammer, boring backfilled upon completion

While Drilling ∇ **20.20 ft**
 At Completion of Drilling ∇ **River**
 Time After Drilling **NA**
 Depth to Water ∇ **NA**

The stratification lines represent the approximate boundary between soil types; the actual transition may be gradual.

WANGENG 7510701.GPJ WANGENG.GDT 12/18/19



wangeng@wangeng.com
 1145 N Main Street
 Lombard, IL 60148
 Telephone: (630) 953-9928
 Fax:

BORING LOG 0125-BSB-03

WEI Job No.: 751-07-01

Client: **HDR Engineering, Inc.**
 Project: **Illinois Route 2 Bridges over the Rock River**
 Location: **Rockton, Winnebago County, Illinois**

Datum: NAVD 88
 Elevation: 736.15 ft
 North: 2108307.54 ft
 East: 2595311.80 ft
 Station: 1136+01.12
 Offset: 45.24 LT

Profile	Elevation (ft)	SOIL AND ROCK DESCRIPTION	Depth (ft)	Sample Type recovery	Sample No.	SPT Values (blw/6 in)	Qu (tsf)	Moisture Content (%)	Profile	Elevation (ft)	SOIL AND ROCK DESCRIPTION	Depth (ft)	Sample Type recovery	Sample No.	SPT Values (blw/6 in)	Qu (tsf)	Moisture Content (%)
			85		12	9 13 14	NP	15				105		16	32 43 47	NP	14
	649.4	Dense, brown, coarse GRAVELLY SAND; wet --RDR 2--			13	15 15 21	NP	15		629.9	Very dense, gray SILT; moist to wet --RDR 2--			17	29 32 28	NP	18
	644.4	Medium dense, brown SANDY GRAVEL; saturated --possible cobbles between 96 to 97.5 feet-- --RDR 3--			14	8 9 11	NP	10		624.4	Hard, pinkish gray SILTY CLAY LOAM, trace gravel			18	27 42 33	6.07 B	8
	638.7	Medium dense to very dense, brown, medium to coarse SAND; wet --RDR 2--			15	14 39 50/4"	NP	17		619.2	Very dense, gray, fine SAND; saturated			19	18 28 33	NP	22

GENERAL NOTES

Begin Drilling **11-19-2019** Complete Drilling **11-20-2019**
 Drilling Contractor **Wang Testing Services** Drill Rig
 Driller **R&J&K** Logger **F. Bozga** Checked by **M. Snider**
 Drilling Method **2.25" ID HSA to 30'; mud rotary thereafter;**
autohammer, boring backfilled upon completion

WATER LEVEL DATA

While Drilling ∇ **20.20 ft**
 At Completion of Drilling ∇ **River**
 Time After Drilling **NA**
 Depth to Water ∇ **NA**
 The stratification lines represent the approximate boundary between soil types; the actual transition may be gradual.

WANGENG 7510701.GPJ WANGENG.GDT 12/18/19



wangeng@wangeng.com
 1145 N Main Street
 Lombard, IL 60148
 Telephone: (630) 953-9928
 Fax:

BORING LOG 0125-BSB-03

WEI Job No.: 751-07-01

Client **HDR Engineering, Inc.**
 Project **Illinois Route 2 Bridges over the Rock River**
 Location **Rockton, Winnebago County, Illinois**

Datum: NAVD 88
 Elevation: 736.15 ft
 North: 2108307.54 ft
 East: 2595311.80 ft
 Station: 1136+01.12
 Offset: 45.24 LT

Profile	Elevation (ft)	SOIL AND ROCK DESCRIPTION	Depth (ft)	Sample Type recovery	Sample No.	SPT Values (blw/6 in)	Qu (tsf)	Moisture Content (%)	Profile	Elevation (ft)	SOIL AND ROCK DESCRIPTION	Depth (ft)	Sample Type recovery	Sample No.	SPT Values (blw/6 in)	Qu (tsf)	Moisture Content (%)
	614.2	Dense, gray SILT; saturated	125		20	10 19 22	NP	23									
	609.4	Very dense, gray, very fine SAND; saturated	130		21	23 32 35	NP	24									
	606.2	Boring terminated at 130.00 ft	135														
			140														

GENERAL NOTES

Begin Drilling **11-19-2019** Complete Drilling **11-20-2019**
 Drilling Contractor **Wang Testing Services** Drill Rig
 Driller **R&J&K** Logger **F. Bozga** Checked by **M. Snider**
 Drilling Method **2.25" ID HSA to 30'; mud rotary thereafter;**
autohammer, boring backfilled upon completion

WATER LEVEL DATA

While Drilling ∇ **20.20 ft**
 At Completion of Drilling \blacktriangledown **River**
 Time After Drilling **NA**
 Depth to Water ∇ **NA**

The stratification lines represent the approximate boundary between soil types; the actual transition may be gradual.



wangeng@wangeng.com
 1145 N Main Street
 Lombard, IL 60148
 Telephone: (630) 953-9928
 Fax:

BORING LOG 0125-BSB-04

WEI Job No.: 751-07-01

Client **HDR Engineering, Inc.**
 Project **Illinois Route 2 Bridges over the Rock River**
 Location **Rockton, Winnebago County, Illinois**

Datum: NAVD 88
 Elevation: 736.08 ft
 North: 2108541.57 ft
 East: 2595308.83 ft
 Station: 1138+35.17
 Offset: 46.19 LT

Profile	Elevation (ft)	SOIL AND ROCK DESCRIPTION	Depth (ft)	Sample Type recovery	Sample No.	SPT Values (blw/6 in)	Qu (tsf)	Moisture Content (%)	Profile	Elevation (ft)	SOIL AND ROCK DESCRIPTION	Depth (ft)	Sample Type recovery	Sample No.	SPT Values (blw/6 in)	Qu (tsf)	Moisture Content (%)	
	734.9	2.5-inch thick, ASPHALT over 11.5-inch thick CONCRETE --PAVEMENT--																
	733.8	Brown CRUSHED STONE --AGGREGATE BASE--																
		Medium dense to dense, brown, medium to coarse SAND, some gravel; moist --FILL-- --RDR 2--	5	X	1	5 10 11	NP	7								9 9 11	NP	20
			10	X	2	14 16 24	NP	4								6 7 6	NP	13
	724.3	Dense, dark brown SANDY GRAVEL; damp --RDR 2--	15	X	3	9 24 20	NP	13							5 11 11	NP	12	
	719.3	Medium dense, brown, fine to medium SAND, trace gravel; wet --RDR 2--	20	X	4	13 10 8	NP	20							14 12 13	NP	8	

GENERAL NOTES

WATER LEVEL DATA

Begin Drilling **10-29-2019** Complete Drilling **10-29-2019**
 Drilling Contractor **Wang Testing Services** Drill Rig
 Driller **RR&JD** Logger **F. Bozga** Checked by **M. Snider**
 Drilling Method **2.25" IDA HSA to 10'; mud rotary thereafter;**
autohammer, boring backfilled upon completion

While Drilling ∇ **11.75 ft**
 At Completion of Drilling ∇ **12' Mud**
 Time After Drilling **NA**
 Depth to Water ∇ **NA**

The stratification lines represent the approximate boundary between soil types; the actual transition may be gradual.

WANGENG 7510701.GPJ WANGENG.GDT 12/18/19



wangeng@wangeng.com
 1145 N Main Street
 Lombard, IL 60148
 Telephone: (630) 953-9928
 Fax:

BORING LOG 0125-BSB-04

WEI Job No.: 751-07-01

Client **HDR Engineering, Inc.**
 Project **Illinois Route 2 Bridges over the Rock River**
 Location **Rockton, Winnebago County, Illinois**

Datum: NAVD 88
 Elevation: 736.08 ft
 North: 2108541.57 ft
 East: 2595308.83 ft
 Station: 1138+35.17
 Offset: 46.19 LT

Profile	Elevation (ft)	SOIL AND ROCK DESCRIPTION	Depth (ft)	Sample Type recovery	Sample No.	SPT Values (blw/6 in)	Qu (tsf)	Moisture Content (%)	Profile	Elevation (ft)	SOIL AND ROCK DESCRIPTION	Depth (ft)	Sample Type recovery	Sample No.	SPT Values (blw/6 in)	Qu (tsf)	Moisture Content (%)
	694.3	--possible cobbles--															
		Medium dense, brown, coarse SAND, trace gravel; wet --RDR 2--	45		9	13 13 13	NP	17				65		13	10 15 21	NP	16
	689.3	Medium dense, brown SANDY GRAVEL; wet --RDR 2--	50		10	7 7 9	NP	12				70		14	16 23 29	NP	16
	684.3	Dense to very dense, brown, medium to coarse SAND, trace to little gravel; wet --RDR 2--	55		11	15 16 25	NP	14				75		15	11 15 15	NP	17
			60		12	19 21 30	NP	15				80		16	19 25 26	NP	15

GENERAL NOTES

Begin Drilling **10-29-2019** Complete Drilling **10-29-2019**
 Drilling Contractor **Wang Testing Services** Drill Rig
 Driller **RR&JD** Logger **F. Bozga** Checked by **M. Snider**
 Drilling Method **2.25" IDA HSA to 10'; mud rotary thereafter;**
autohammer, boring backfilled upon completion

WATER LEVEL DATA

While Drilling **11.75 ft**
 At Completion of Drilling **12' Mud**
 Time After Drilling **NA**
 Depth to Water **NA**

The stratification lines represent the approximate boundary between soil types; the actual transition may be gradual.

WANGENG 7510701.GPJ WANGENG.GDT 12/18/19



wangeng@wangeng.com
 1145 N Main Street
 Lombard, IL 60148
 Telephone: (630) 953-9928
 Fax:

BORING LOG 0125-BSB-04

WEI Job No.: 751-07-01

Client: **HDR Engineering, Inc.**
 Project: **Illinois Route 2 Bridges over the Rock River**
 Location: **Rockton, Winnebago County, Illinois**

Datum: NAVD 88
 Elevation: 736.08 ft
 North: 2108541.57 ft
 East: 2595308.83 ft
 Station: 1138+35.17
 Offset: 46.19 LT

Profile	Elevation (ft)	SOIL AND ROCK DESCRIPTION	Depth (ft)	Sample Type recovery	Sample No.	SPT Values (blw/6 in)	Qu (tsf)	Moisture Content (%)	Profile	Elevation (ft)	SOIL AND ROCK DESCRIPTION	Depth (ft)	Sample Type recovery	Sample No.	SPT Values (blw/6 in)	Qu (tsf)	Moisture Content (%)
	654.3																
		Very dense, brown, gravelly coarse SAND; wet --RDR 2--			17	16 21 30	NP	13									
	650.1	--possible cobbles--															
		Very stiff to hard, pinkish gray SILTY CLAY --RDR 2--			18	8 10 12	4.84 B	22									
	641.6																
		Dense to very dense, brown SANDY GRAVEL to GRAVELLY SAND; wet --RDR 3-- --possible cobbles--			19	5 12 32	3.61 B	23									
	636.1																
					20	31 48 48	NP	14									
Boring terminated at 100.00 ft																	

GENERAL NOTES

WATER LEVEL DATA

Begin Drilling **10-29-2019** Complete Drilling **10-29-2019**
 Drilling Contractor **Wang Testing Services** Drill Rig
 Driller **RR&JD** Logger **F. Bozga** Checked by **M. Snider**
 Drilling Method **2.25" IDA HSA to 10'; mud rotary thereafter;**
autohammer, boring backfilled upon completion

While Drilling ∇ **11.75 ft**
 At Completion of Drilling ∇ **12' Mud**
 Time After Drilling **NA**
 Depth to Water ∇ **NA**

The stratification lines represent the approximate boundary between soil types; the actual transition may be gradual.

WANGENGINC 7510701.GPJ WANGENG.GDT 12/18/19



wangeng@wangeng.com
 1145 N Main Street
 Lombard, IL 60148
 Telephone: (630) 953-9928
 Fax:

BORING LOG 0126-BSB-01

WEI Job No.: 751-07-01

Client **HDR Engineering, Inc.**
 Project **Illinois Route 2 Bridges over the Rock River**
 Location **Rockton, Winnebago County, Illinois**

Datum: NAVD 88
 Elevation: 736.39 ft
 North: 2107841.08 ft
 East: 2595406.02 ft
 Station: 1131+33.87
 Offset: 44.94 RT

Profile	Elevation (ft)	SOIL AND ROCK DESCRIPTION	Depth (ft)	Sample Type recovery	Sample No.	SPT Values (blw/6 in)	Qu (tsf)	Moisture Content (%)	Profile	Elevation (ft)	SOIL AND ROCK DESCRIPTION	Depth (ft)	Sample Type recovery	Sample No.	SPT Values (blw/6 in)	Qu (tsf)	Moisture Content (%)	
	735.2	3-inch thick ASPHALT over 11-inch thick CONCRETE --PAVEMENT--																
	733.9	Brown CRUSHED STONE --AGGREGATE BASE--									--rig chatter at 22.5 feet--							
		Very loose to medium dense, dark brown, fine to medium SAND; damp to moist --FILL-- --RDR 1 to 2--	5	X	1	7 8 6	NP	8			Medium dense, brown SANDY GRAVEL; saturated --RDR 2--	25	X	5	6 7 10	NP	7	
			10	X	2	1 1 1	NP	7				30	X	6	8 10 13	NP	10	
			15	X	3	2 2 3	NP	16				35	X	7	5 8 9	NP	11	
	719.6	Very soft, brown SILTY CLAY LOAM --RDR 1--	20	X	4	0 1 2	0.16 B	20			704.6							
											Medium dense, brown GRAVELLY SAND; saturated --RDR 2--	40	X	8	10 11 12	NP	14	

GENERAL NOTES

WATER LEVEL DATA

Begin Drilling **11-01-2019** Complete Drilling **11-01-2019**
 Drilling Contractor **Wang Testing Services** Drill Rig
 Driller **RR&JD** Logger **F. Bozga** Checked by **M. Snider**
 Drilling Method **2.25" IDA HSA to 10'; mud rotary thereafter;**
autohammer, boring backfilled upon completion

While Drilling ∇ **12.00 ft**
 At Completion of Drilling ∇ **10' Mud**
 Time After Drilling **NA**
 Depth to Water ∇ **NA**

The stratification lines represent the approximate boundary between soil types; the actual transition may be gradual.

WANGENGINC 7510701.GPJ WANGENG.GDT 12/18/19



wangeng@wangeng.com
 1145 N Main Street
 Lombard, IL 60148
 Telephone: (630) 953-9928
 Fax:

BORING LOG 0126-BSB-01

WEI Job No.: 751-07-01

Client **HDR Engineering, Inc.**
 Project **Illinois Route 2 Bridges over the Rock River**
 Location **Rockton, Winnebago County, Illinois**

Datum: NAVD 88
 Elevation: 736.39 ft
 North: 2107841.08 ft
 East: 2595406.02 ft
 Station: 1131+33.87
 Offset: 44.94 RT

Profile	Elevation (ft)	SOIL AND ROCK DESCRIPTION	Depth (ft)	Sample Type recovery	Sample No.	SPT Values (blw/6 in)	Qu (tsf)	Moisture Content (%)	Profile	Elevation (ft)	SOIL AND ROCK DESCRIPTION	Depth (ft)	Sample Type recovery	Sample No.	SPT Values (blw/6 in)	Qu (tsf)	Moisture Content (%)
	694.6																
		Medium dense, brown, medium to coarse SAND, trace gravel; wet --RDR 2--	45		9	10 10 11	NP	18			--coarse--	65		13	10 13 13	NP	17
	689.6	Medium dense, brown GRAVELLY SAND; wet --RDR 2--	50		10	8 6 6	NP	15			--fine--	70		14	16 20 23	NP	19
	684.6	Medium dense to very dense, brown, medium SAND, trace gravel; wet to saturated --RDR 2--	55		11	15 16 19	NP	14				75		15	9 13 15	NP	17
			60		12	12 21 29	NP	17				80		16	18 23 23	NP	17

GENERAL NOTES

Begin Drilling **11-01-2019** Complete Drilling **11-01-2019**
 Drilling Contractor **Wang Testing Services** Drill Rig
 Driller **RR&JD** Logger **F. Bozga** Checked by **M. Snider**
 Drilling Method **2.25" IDA HSA to 10'; mud rotary thereafter;**
autohammer, boring backfilled upon completion

WATER LEVEL DATA

While Drilling ∇ **12.00 ft**
 At Completion of Drilling ∇ **10' Mud**
 Time After Drilling **NA**
 Depth to Water ∇ **NA**

The stratification lines represent the approximate boundary between soil types; the actual transition may be gradual.

WANGENG 7510701.GPJ WANGENG.GDT 12/18/19



wangeng@wangeng.com
 1145 N Main Street
 Lombard, IL 60148
 Telephone: (630) 953-9928
 Fax:

BORING LOG 0126-BSB-01

WEI Job No.: 751-07-01

Client **HDR Engineering, Inc.**
 Project **Illinois Route 2 Bridges over the Rock River**
 Location **Rockton, Winnebago County, Illinois**

Datum: NAVD 88
 Elevation: 736.39 ft
 North: 2107841.08 ft
 East: 2595406.02 ft
 Station: 1131+33.87
 Offset: 44.94 RT

Profile	Elevation (ft)	SOIL AND ROCK DESCRIPTION	Depth (ft)	Sample Type recovery	Sample No.	SPT Values (blw/6 in)	Qu (tsf)	Moisture Content (%)	Profile	Elevation (ft)	SOIL AND ROCK DESCRIPTION	Depth (ft)	Sample Type recovery	Sample No.	SPT Values (blw/6 in)	Qu (tsf)	Moisture Content (%)
	654.6	--rig chatter--															
		Very dense, brown SANDY GRAVEL; wet --RDR 3 to 4--			17	47 50/5"	NP	16									
	649.6	Dense, brown, medium SAND; wet --RDR 2--			18	23 13 20	NP	18									
	646.6	Very stiff (2.50 P), pinkish gray SILTY CLAY	90														
	644.6	Very dense, brown, medium SAND; wet --RDR 2--			19	20 21 43	NP	16									
		--rig chatter, possible cobbles--	95														
	640.4	Medium dense, brown SANDY GRAVEL; wet --RDR 3--			20	10 10 10	NP	10									
	636.4	Boring terminated at 100.00 ft	100														

GENERAL NOTES

WATER LEVEL DATA

Begin Drilling **11-01-2019** Complete Drilling **11-01-2019**
 Drilling Contractor **Wang Testing Services** Drill Rig
 Driller **RR&JD** Logger **F. Bozga** Checked by **M. Snider**
 Drilling Method **2.25" IDA HSA to 10'; mud rotary thereafter;**
autohammer, boring backfilled upon completion

While Drilling **12.00 ft**
 At Completion of Drilling **10' Mud**
 Time After Drilling **NA**
 Depth to Water **NA**

The stratification lines represent the approximate boundary between soil types; the actual transition may be gradual.

WANGENG 7510701.GPJ WANGENG.GDT 12/18/19



wangeng@wangeng.com
 1145 N Main Street
 Lombard, IL 60148
 Telephone: (630) 953-9928
 Fax:

BORING LOG 0126-BSB-02

WEI Job No.: 751-07-01

Client **HDR Engineering, Inc.**
 Project **Illinois Route 2 Bridges over the Rock River**
 Location **Rockton, Winnebago County, Illinois**

Datum: NAVD 88
 Elevation: 735.90 ft
 North: 2108058.68 ft
 East: 2595403.04 ft
 Station: 1133+51.49
 Offset: 43.85 RT

Profile	Elevation (ft)	SOIL AND ROCK DESCRIPTION	Depth (ft)	Sample Type recovery	Sample No.	SPT Values (blw/6 in)	Qu (tsf)	Moisture Content (%)	Profile	Elevation (ft)	SOIL AND ROCK DESCRIPTION	Depth (ft)	Sample Type recovery	Sample No.	SPT Values (blw/6 in)	Qu (tsf)	Moisture Content (%)
	735.1	10-inch thick CONCRETE --BRIDGE DECK-- --clearance to water level, approx. 19 feet--	5														
	705.9	Medium dense to dense, brown SANDY GRAVEL; saturated --RDR 2-- --%Gravel = 67.5%-- --%Sand = 30.0%-- --% Silt and Clay = 2.5%--	30		1	15 17 18											10
			35		2	8 6 6											11
	699.3	Medium dense, coarse GRAVELLY SAND; saturated --RDR 2--															
	716.6	--Rock River--	20		3	9 7 8											13

GENERAL NOTES

WATER LEVEL DATA

Begin Drilling **11-15-2019** Complete Drilling **11-18-2019**
 Drilling Contractor **Wang Testing Services** Drill Rig
 Driller **R&J&K** Logger **F. Bozga** Checked by **M. Snider**
 Drilling Method **2.25" ID HSA to 30'; mud rotary thereafter;**
autohammer, boring backfilled upon completion

While Drilling **19.25 ft**
 At Completion of Drilling **River**
 Time After Drilling **NA**
 Depth to Water **NA**

The stratification lines represent the approximate boundary between soil types; the actual transition may be gradual.

WANGENGINC 7510701.GPJ WANGENG.GDT 12/18/19



wangeng@wangeng.com
 1145 N Main Street
 Lombard, IL 60148
 Telephone: (630) 953-9928
 Fax:

BORING LOG 0126-BSB-02

WEI Job No.: 751-07-01

Client **HDR Engineering, Inc.**
 Project **Illinois Route 2 Bridges over the Rock River**
 Location **Rockton, Winnebago County, Illinois**

Datum: NAVD 88
 Elevation: 735.90 ft
 North: 2108058.68 ft
 East: 2595403.04 ft
 Station: 1133+51.49
 Offset: 43.85 RT

Profile	Elevation (ft)	SOIL AND ROCK DESCRIPTION	Depth (ft)	Sample Type recovery	Sample No.	SPT Values (blw/6 in)	Qu (tsf)	Moisture Content (%)	Profile	Elevation (ft)	SOIL AND ROCK DESCRIPTION	Depth (ft)	Sample Type recovery	Sample No.	SPT Values (blw/6 in)	Qu (tsf)	Moisture Content (%)
	694.1																
		Medium dense to dense, brown, fine to coarse SAND; wet to saturated --RDR 2--															
			45		4	9 6 6	NP	19				65		8	10 11 12	NP	17
			50		5	7 6 6	NP	22				70		9	10 12 16	NP	25
			55		6	6 7 8	NP	17				75		10	12 22 25	NP	19
			60		7	8 13 14	NP	17				80		11	11 14 20	NP	16
										655.9							

GENERAL NOTES

WATER LEVEL DATA

Begin Drilling **11-15-2019** Complete Drilling **11-18-2019**
 Drilling Contractor **Wang Testing Services** Drill Rig
 Driller **R&J&K** Logger **F. Bozga** Checked by **M. Snider**
 Drilling Method **2.25" ID HSA to 30'; mud rotary thereafter;**
autohammer, boring backfilled upon completion

While Drilling **19.25 ft**
 At Completion of Drilling **River**
 Time After Drilling **NA**
 Depth to Water **NA**

The stratification lines represent the approximate boundary between soil types; the actual transition may be gradual.

WANGENGINC 7510701.GPJ WANGENG.GDT 12/18/19



wangeng@wangeng.com
 1145 N Main Street
 Lombard, IL 60148
 Telephone: (630) 953-9928
 Fax:

BORING LOG 0126-BSB-02

WEI Job No.: 751-07-01

Client **HDR Engineering, Inc.**
 Project **Illinois Route 2 Bridges over the Rock River**
 Location **Rockton, Winnebago County, Illinois**

Datum: NAVD 88
 Elevation: 735.90 ft
 North: 2108058.68 ft
 East: 2595403.04 ft
 Station: 1133+51.49
 Offset: 43.85 RT

Profile	Elevation (ft)	SOIL AND ROCK DESCRIPTION	Depth (ft)	Sample Type recovery	Sample No.	SPT Values (blw/6 in)	Qu (tsf)	Moisture Content (%)	Profile	Elevation (ft)	SOIL AND ROCK DESCRIPTION	Depth (ft)	Sample Type recovery	Sample No.	SPT Values (blw/6 in)	Qu (tsf)	Moisture Content (%)
	613.9	Dense, gray, very fine SAND; wet --RDR 2--	125		20	20 21 20	NP	19									
	609.6	Dense, gray SILT; saturated --RDR 2--	130		21	13 21 21	NP	20									
	605.9	Boring terminated at 130.00 ft	135														
			140														

GENERAL NOTES

WATER LEVEL DATA

Begin Drilling **11-15-2019** Complete Drilling **11-18-2019**
 Drilling Contractor **Wang Testing Services** Drill Rig
 Driller **R&J&K** Logger **F. Bozga** Checked by **M. Snider**
 Drilling Method **2.25" ID HSA to 30'; mud rotary thereafter;**
autohammer, boring backfilled upon completion

While Drilling ∇ **19.25 ft**
 At Completion of Drilling ∇ **River**
 Time After Drilling **NA**
 Depth to Water ∇ **NA**

The stratification lines represent the approximate boundary between soil types; the actual transition may be gradual.



wangeng@wangeng.com
 1145 N Main Street
 Lombard, IL 60148
 Telephone: (630) 953-9928
 Fax:

BORING LOG 0126-BSB-03

WEI Job No.: 751-07-01

Client: **HDR Engineering, Inc.**
 Project: **Illinois Route 2 Bridges over the Rock River**
 Location: **Rockton, Winnebago County, Illinois**

Datum: NAVD 88
 Elevation: 736.16 ft
 North: 2108266.10 ft
 East: 2595401.65 ft
 Station: 1135+58.91
 Offset: 44.25 RT

Profile	Elevation (ft)	SOIL AND ROCK DESCRIPTION	Depth (ft)	Sample Type recovery	Sample No.	SPT Values (blw/6 in)	Qu (tsf)	Moisture Content (%)	Profile	Elevation (ft)	SOIL AND ROCK DESCRIPTION	Depth (ft)	Sample Type recovery	Sample No.	SPT Values (blw/6 in)	Qu (tsf)	Moisture Content (%)
	735.4	9.75-inch thick, CONCRETE --BRIDGE DECK-- --clearance to water level, approx. 19 feet--	5									25					
			10							707.2	Loose to medium dense, brown SANDY GRAVEL; saturated --RDR 2 to 3--	30	1	7 10 12		NP	13
			15								--gravel and cobbles-- --%Gravel = 78.6%-- --%Sand = 17.8%-- --% Silt and Clay = 3.6%--	35	2	15 13 7		NP	20
	716.8	--Rock River--	20									40	3	7 3 3		NP	17

GENERAL NOTES

Begin Drilling **11-08-2019** Complete Drilling **11-13-2019**
 Drilling Contractor **Wang Testing Services** Drill Rig
 Driller **RR&JD** Logger **F. Bozga** Checked by **M. Snider**
 Drilling Method **2.25" IDA HSA to 19'; mud rotary thereafter;**
autohammer, boring backfilled upon completion

WATER LEVEL DATA

While Drilling **19.33 ft**
 At Completion of Drilling **River**
 Time After Drilling **NA**
 Depth to Water **NA**

The stratification lines represent the approximate boundary between soil types; the actual transition may be gradual.

WANGENGINC 7510701.GPJ WANGENG.GDT 12/18/19



wangeng@wangeng.com
 1145 N Main Street
 Lombard, IL 60148
 Telephone: (630) 953-9928
 Fax:

BORING LOG 0126-BSB-03

WEI Job No.: 751-07-01

Client **HDR Engineering, Inc.**
 Project **Illinois Route 2 Bridges over the Rock River**
 Location **Rockton, Winnebago County, Illinois**

Datum: NAVD 88
 Elevation: 736.16 ft
 North: 2108266.10 ft
 East: 2595401.65 ft
 Station: 1135+58.91
 Offset: 44.25 RT

Profile	Elevation (ft)	SOIL AND ROCK DESCRIPTION	Depth (ft)	Sample Type recovery	Sample No.	SPT Values (blw/6 in)	Qu (tsf)	Moisture Content (%)	Profile	Elevation (ft)	SOIL AND ROCK DESCRIPTION	Depth (ft)	Sample Type recovery	Sample No.	SPT Values (blw/6 in)	Qu (tsf)	Moisture Content (%)
	694.4																
		Medium dense, brown, fine to medium SAND; saturated --RDR 4--			4	9 8 5	NP	19						8	7 8 8	NP	17
	691.2		45														
		Medium dense, brown, fine to coarse SAND; wet to saturated --RDR 2--			5	7 5 5	NP	23						9	7 13 14	NP	35
			50														
					6	7 7 7	NP	17						10	7 10 12	NP	21
			55														
					7	11 13 15	NP	22						11	8 13 14	NP	20
			60														

GENERAL NOTES

Begin Drilling **11-08-2019** Complete Drilling **11-13-2019**
 Drilling Contractor **Wang Testing Services** Drill Rig
 Driller **RR&JD** Logger **F. Bozga** Checked by **M. Snider**
 Drilling Method **2.25" IDA HSA to 19'; mud rotary thereafter;**
autohammer, boring backfilled upon completion

WATER LEVEL DATA

While Drilling **19.33 ft**
 At Completion of Drilling **River**
 Time After Drilling **NA**
 Depth to Water **NA**
 The stratification lines represent the approximate boundary between soil types; the actual transition may be gradual.

WANGENGINC 7510701.GPJ WANGENG.GDT 12/18/19



wangeng@wangeng.com
 1145 N Main Street
 Lombard, IL 60148
 Telephone: (630) 953-9928
 Fax:

BORING LOG 0126-BSB-03

WEI Job No.: 751-07-01

Client **HDR Engineering, Inc.**
 Project **Illinois Route 2 Bridges over the Rock River**
 Location **Rockton, Winnebago County, Illinois**

Datum: NAVD 88
 Elevation: 736.16 ft
 North: 2108266.10 ft
 East: 2595401.65 ft
 Station: 1135+58.91
 Offset: 44.25 RT

Profile	Elevation (ft)	SOIL AND ROCK DESCRIPTION	Depth (ft)	Sample Type recovery	Sample No.	SPT Values (blw/6 in)	Qu (tsf)	Moisture Content (%)	Profile	Elevation (ft)	SOIL AND ROCK DESCRIPTION	Depth (ft)	Sample Type recovery	Sample No.	SPT Values (blw/6 in)	Qu (tsf)	Moisture Content (%)	
											--possible cobbles--							
			85		12	10 11 16	NP	15				105		16	14 20 30	NP	8	
	649.4	Very dense, brown, coarse GRAVELLY SAND; wet --RDR 2--																
			90		13	19 27 25	NP	13				110		17	27 28 47	8.69 S	10	
	644.4	Dense, brown, medium SAND, trace gravel; wet																
			95		14	12 22 23	NP	17				115		18	32 41 35	> 4.50 P	17	
	639.4	Medium dense to very dense, brown SANDY GRAVEL; wet --RDR 2 to 3--																
			100		15	11 11 12	NP	13				120		19	29 45 50/5"	NP	15	

GENERAL NOTES

WATER LEVEL DATA

Begin Drilling **11-08-2019** Complete Drilling **11-13-2019**
 Drilling Contractor **Wang Testing Services** Drill Rig
 Driller **RR&JD** Logger **F. Bozga** Checked by **M. Snider**
 Drilling Method **2.25" IDA HSA to 19'; mud rotary thereafter;**
autohammer, boring backfilled upon completion

While Drilling ∇ **19.33 ft**
 At Completion of Drilling ∇ **River**
 Time After Drilling **NA**
 Depth to Water ∇ **NA**

The stratification lines represent the approximate boundary between soil types; the actual transition may be gradual.

WANGENG 7510701.GPJ WANGENG.GDT 12/18/19



wangeng@wangeng.com
 1145 N Main Street
 Lombard, IL 60148
 Telephone: (630) 953-9928
 Fax:

BORING LOG 0126-BSB-03

WEI Job No.: 751-07-01

Client: **HDR Engineering, Inc.**
 Project: **Illinois Route 2 Bridges over the Rock River**
 Location: **Rockton, Winnebago County, Illinois**

Datum: NAVD 88
 Elevation: 736.16 ft
 North: 2108266.10 ft
 East: 2595401.65 ft
 Station: 1135+58.91
 Offset: 44.25 RT

Profile	Elevation (ft)	SOIL AND ROCK DESCRIPTION	Depth (ft)	Sample Type recovery	Sample No.	SPT Values (blw/6 in)	Qu (tsf)	Moisture Content (%)	Profile	Elevation (ft)	SOIL AND ROCK DESCRIPTION	Depth (ft)	Sample Type recovery	Sample No.	SPT Values (blw/6 in)	Qu (tsf)	Moisture Content (%)
	614.4																
		Very dense, gray SILT; moist to wet															
			125		20	18 21 31	NP	25									
	606.2		130		21	25 28 37	NP	20									
		Boring terminated at 130.00 ft															
			135														
			140														

GENERAL NOTES

Begin Drilling **11-08-2019** Complete Drilling **11-13-2019**
 Drilling Contractor **Wang Testing Services** Drill Rig
 Driller **RR&JD** Logger **F. Bozga** Checked by **M. Snider**
 Drilling Method **2.25" IDA HSA to 19'; mud rotary thereafter;**
autohammer, boring backfilled upon completion

WATER LEVEL DATA

While Drilling ∇ **19.33 ft**
 At Completion of Drilling ∇ **River**
 Time After Drilling **NA**
 Depth to Water ∇ **NA**
 The stratification lines represent the approximate boundary between soil types; the actual transition may be gradual.

WANGENGINC 7510701.GPJ WANGENG.GDT 12/18/19



wangeng@wangeng.com
 1145 N Main Street
 Lombard, IL 60148
 Telephone: (630) 953-9928
 Fax:

BORING LOG 0126-BSB-04

WEI Job No.: 751-07-01

Client **HDR Engineering, Inc.**
 Project **Illinois Route 2 Bridges over the Rock River**
 Location **Rockton, Winnebago County, Illinois**

Datum: NAVD 88
 Elevation: 736.00 ft
 North: 2108496.91 ft
 East: 2595401.87 ft
 Station: 1137+89.71
 Offset: 46.46 RT

Profile	Elevation (ft)	SOIL AND ROCK DESCRIPTION	Depth (ft)	Sample Type recovery	Sample No.	SPT Values (blw/6 in)	Qu (tsf)	Moisture Content (%)	Profile	Elevation (ft)	SOIL AND ROCK DESCRIPTION	Depth (ft)	Sample Type recovery	Sample No.	SPT Values (blw/6 in)	Qu (tsf)	Moisture Content (%)
	694.2	Medium dense to dense, brown, fine to coarse SAND; wet --RDR 2--															
			45		9	8 7 10	NP	21				65		13	16 19 22	NP	15
			50		10	13 12 11	NP	16				70		14	16 20 26	NP	18
			55		11	9 15 17	NP	12				75		15	14 17 25	NP	21
			60		12	21 20 16	NP	16				80		16	16 19	NP	14

GENERAL NOTES

Begin Drilling **11-06-2019** Complete Drilling **11-07-2019**
 Drilling Contractor **Wang Testing Services** Drill Rig
 Driller **RR&JD** Logger **F. Bozga** Checked by **M. Snider**
 Drilling Method **2.25" IDA HSA to 10'; mud rotary thereafter;**
autohammer, boring backfilled upon completion

WATER LEVEL DATA

While Drilling **11.00 ft**
 At Completion of Drilling **5' Mud**
 Time After Drilling **21 hours**
 Depth to Water **0.00 ft**

The stratification lines represent the approximate boundary between soil types; the actual transition may be gradual.

WANGENG 7510701.GPJ WANGENG.GDT 12/18/19



wangeng@wangeng.com
 1145 N Main Street
 Lombard, IL 60148
 Telephone: (630) 953-9928
 Fax:

BORING LOG 0126-BSB-04

WEI Job No.: 751-07-01

Client **HDR Engineering, Inc.**
 Project **Illinois Route 2 Bridges over the Rock River**
 Location **Rockton, Winnebago County, Illinois**

Datum: NAVD 88
 Elevation: 736.00 ft
 North: 2108496.91 ft
 East: 2595401.87 ft
 Station: 1137+89.71
 Offset: 46.46 RT

Profile	Elevation (ft)	SOIL AND ROCK DESCRIPTION	Depth (ft)	Sample Type recovery	Sample No.	SPT Values (blw/6 in)	Qu (tsf)	Moisture Content (%)	Profile	Elevation (ft)	SOIL AND ROCK DESCRIPTION	Depth (ft)	Sample Type recovery	Sample No.	SPT Values (blw/6 in)	Qu (tsf)	Moisture Content (%)	
	654.2	Dense to very dense, brown, gravelly coarse SAND; wet --RDR 2--																
				85		17	10 14 22	NP	14									
		--cobbles and boulders--																
				90		18	17 25 31	NP	10									
	644.2	Very dense, brown, medium SAND, clay seams; wet																
				95		19	18 22 33	NP	18									
	639.2	Very dense, brown, gravelly coarse SAND; wet																
				100		20	49 50/4"	NP	13									
	636.0	Boring terminated at 100.00 ft																

GENERAL NOTES

WATER LEVEL DATA

Begin Drilling **11-06-2019** Complete Drilling **11-07-2019**
 Drilling Contractor **Wang Testing Services** Drill Rig
 Driller **RR&JD** Logger **F. Bozga** Checked by **M. Snider**
 Drilling Method **2.25" IDA HSA to 10'; mud rotary thereafter;**
autohammer, boring backfilled upon completion

While Drilling **11.00 ft**
 At Completion of Drilling **5' Mud**
 Time After Drilling **21 hours**
 Depth to Water **0.00 ft**

The stratification lines represent the approximate boundary between soil types; the actual transition may be gradual.

WANGENGINC 7510701.GPJ WANGENG.GDT 12/18/19

APPENDIX B

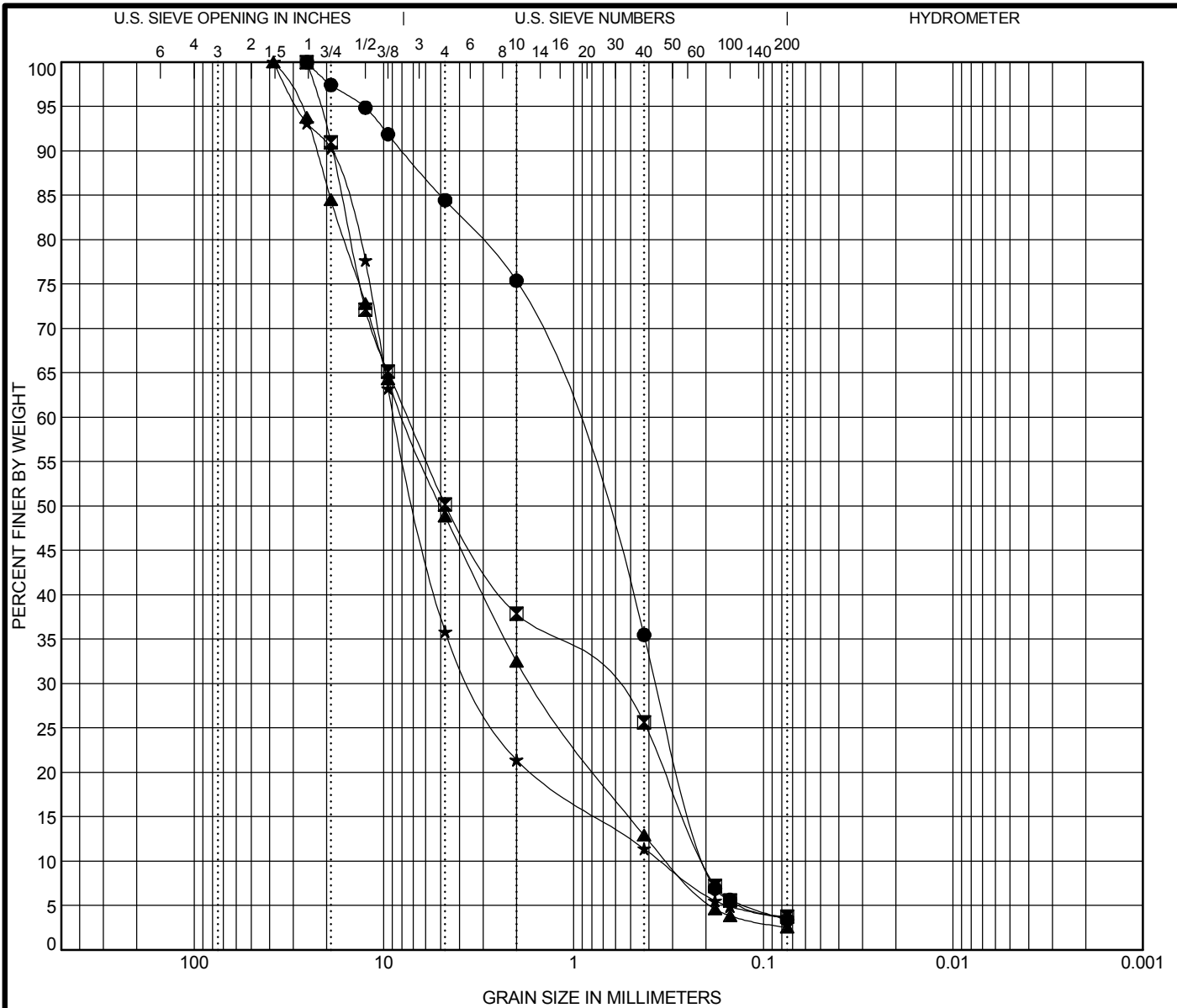

COBBLES	GRAVEL	SAND		SILT AND CLAY
		coarse	fine	

Specimen Identification	IDH Classification	LL	PL	PI	Cc	Cu
● Wang-0125-BSB-02#2 33.5 ft	SAND	NP	NP	NP	0.60	5.57
☒ Wang-0125-BSB-03#1 29.0 ft	SANDY GRAVEL	NP	NP	NP	0.36	36.58
▲ Wang-0126-BSB-02#1 30.0 ft	SANDY GRAVEL	NP	NP	NP	1.10	24.92
★ Wang-0126-BSB-03#2 33.5 ft	SANDY GRAVEL	NP	NP	NP	3.70	25.32

Specimen Identification	D100	D60	D30	D10	%Gravel	%Sand	%Silt	%Clay
● Wang-0125-BSB-02#2 33.5 ft	25.4	1.101	0.36	0.197	24.6	72.0	3.4	
☒ Wang-0125-BSB-03#1 29.0 ft	25.4	7.493	0.739	0.205	62.1	31.4	3.8	
▲ Wang-0126-BSB-02#1 30.0 ft	38.1	7.831	1.642	0.314	67.5	30.0	2.5	
★ Wang-0126-BSB-03#2 33.5 ft	38.1	8.749	3.345	0.346	78.6	17.8	3.6	



Wang Engineering, Inc.
 1145 N Main Street
 Lombard, IL 60148
 Telephone: (630) 953-9928
 Fax:

GRAIN SIZE DISTRIBUTION

Project: Illinois Route 2 Bridges over the Rock River
 Location: Rockton, Winnebago County, Illinois
 Number: 751-07-01

WEI GRAIN SIZE IDH 7510701.GPJ US LAB.GDT 12/11/19

APPENDIX C

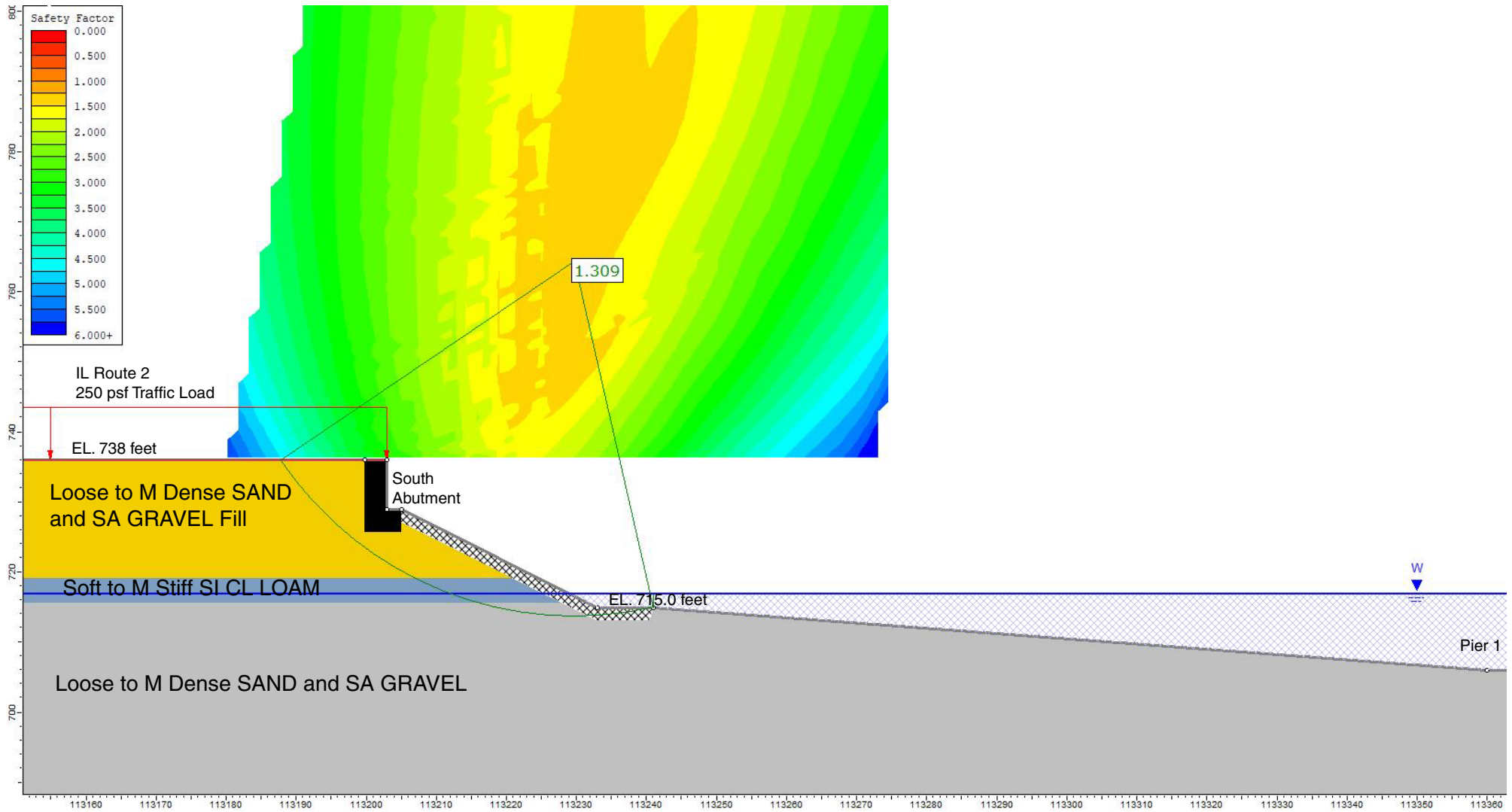

Undrained Analysis, South Abutment End Slope, Spencer Method of Analysis, Ref Borings: 0125-BSB-01 and 01269-BSB-01

Layer ID	Description	Total Unit Weight (pcf)	Undrained Cohesion (psf)	Undrained Friction Angle (degrees)
1	Loose to M Dense SAND and SA GRAVEL FILL	120	0	32
2	Soft to M Stiff SI CLAY LOAM	115	400	0
3	Loose to M Dense SAND and SA GRAVEL	125	0	32

GLOBAL STABILITY IL RTE 2 BRIDGES OVER THE ROCK RIVER
 SNs 101-0125 & 101-0126, IDOT D-92-022-15, WINNEBAGO COUNTY

SCALE: GRAPHICAL

APPENDIX C-1

DRAWN BY: N. Balakumaran
 CHECKED BY: M. Snider



1145 N. Main Street
 Lombard, IL 60148
 www.wangeng.com

FOR HDR ENGINEERING

751-07-01

c:\pwworking\oma\2189634\101XXXX-101XXXX-TSL-01.dgn
bsayers

2/3/2021
8:27:04 AM

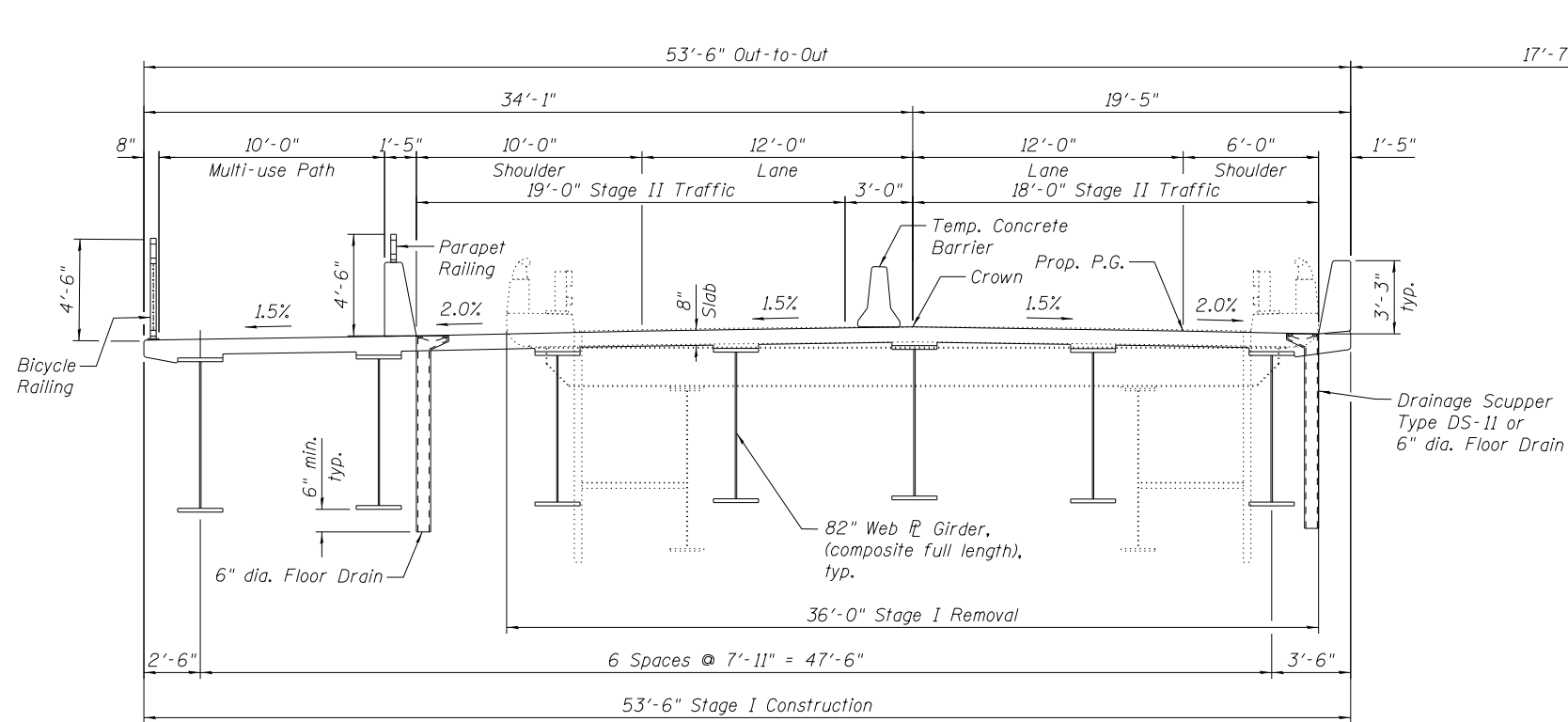

CROSS SECTION
(Looking North)

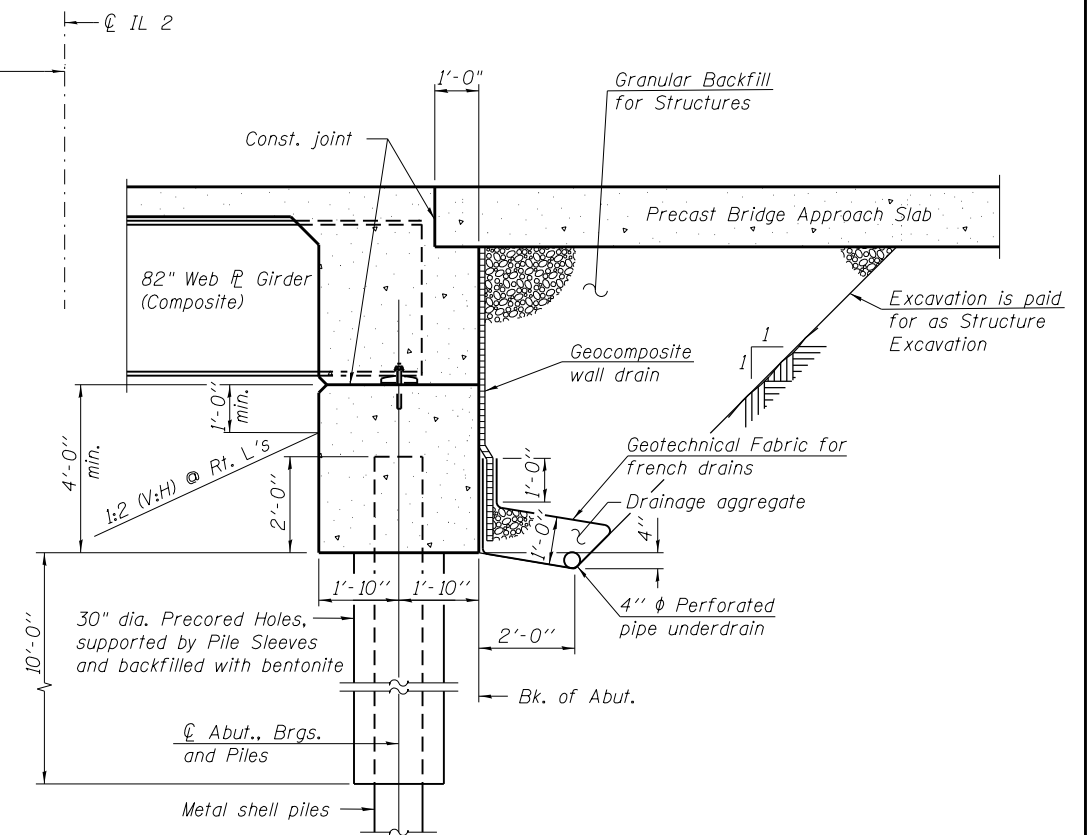

SECTION THRU ABUTMENTS
(Horiz. dim. @ Rt. L's)

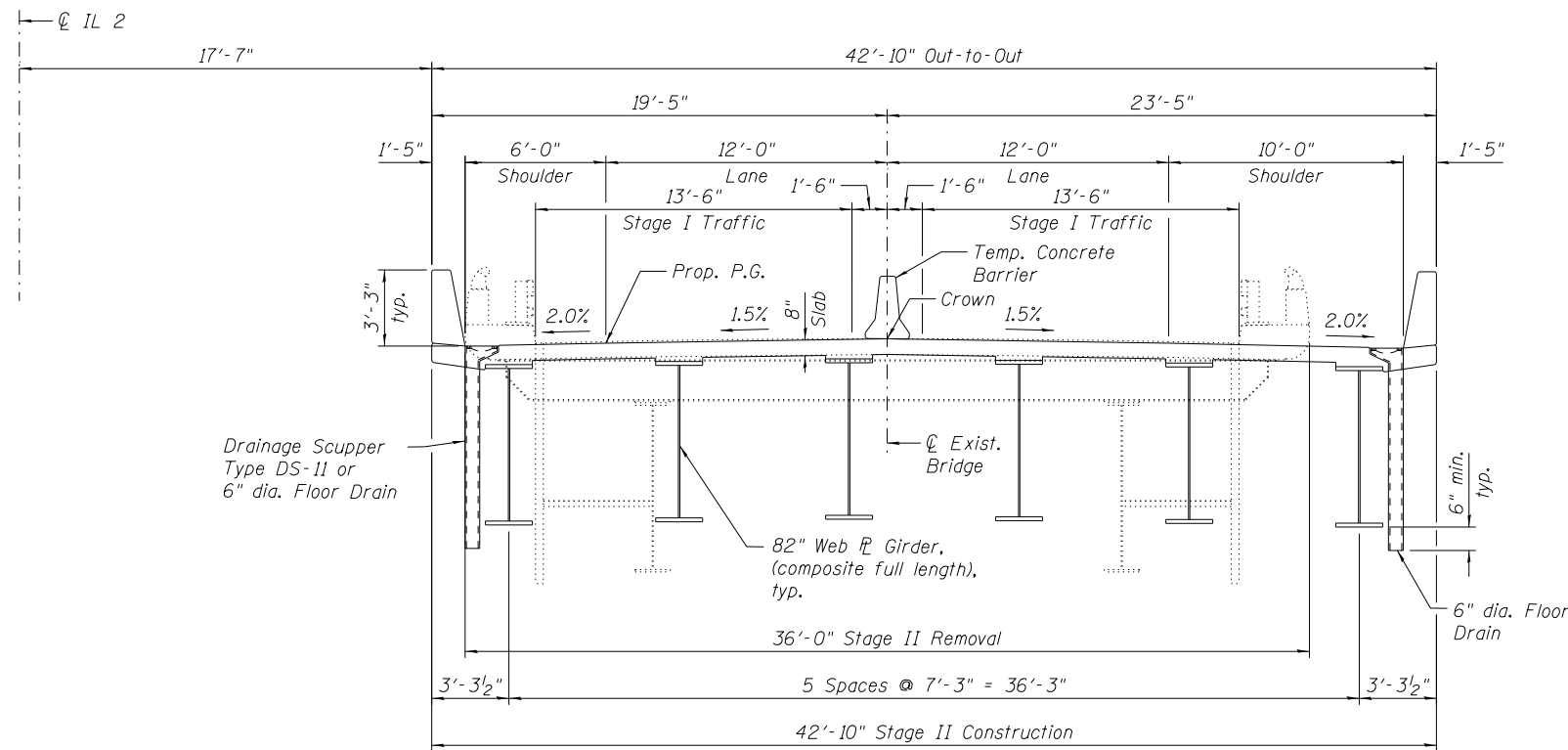

CROSS SECTION
(Looking North)

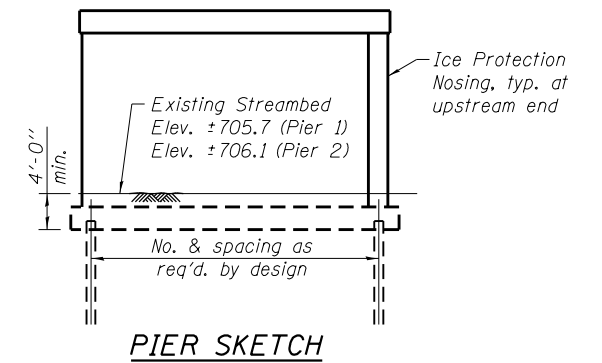
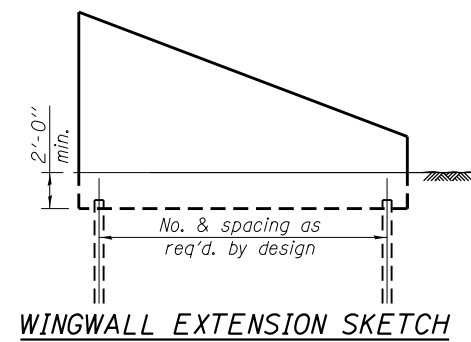

DETAILS
IL 2 OVER ROCK RIVER
PUBLIC WATERS
F.A.P. 734 (IL RTE. 2) - SEC. 77-1BR
WINNEBAGO COUNTY
STATION 1134+83.59
STRUCTURE NO. 101-0221 (S.B.)
STRUCTURE NO. 101-0222 (N.B.)



USER NAME = bsayers	DESIGNED - RGB	REVISED -
FILE NAME = 101XXXX-101XXXX-TSL-01.DGN	CHECKED - JLP	REVISED -
PLOT SCALE = NONE	DRAWN - JM	REVISED -
PLOT DATE = 2/3/2021	CHECKED - JLP	REVISED -

STATE OF ILLINOIS
DEPARTMENT OF TRANSPORTATION

SHEET NO. 2 OF 2 SHEETS

F.A.U. RTE.	SECTION	COUNTY	TOTAL SHEETS	SHEET NO.
734	77-1BR	WINNEBAGO		
CONTRACT NO.				
ILLINOIS FED. AID PROJECT				