

**EXISTING TYPICAL SECTION**

STA 449+81 TO STA 451+71  
 STA 454+65 TO STA 457+63  
 NOT TO SCALE

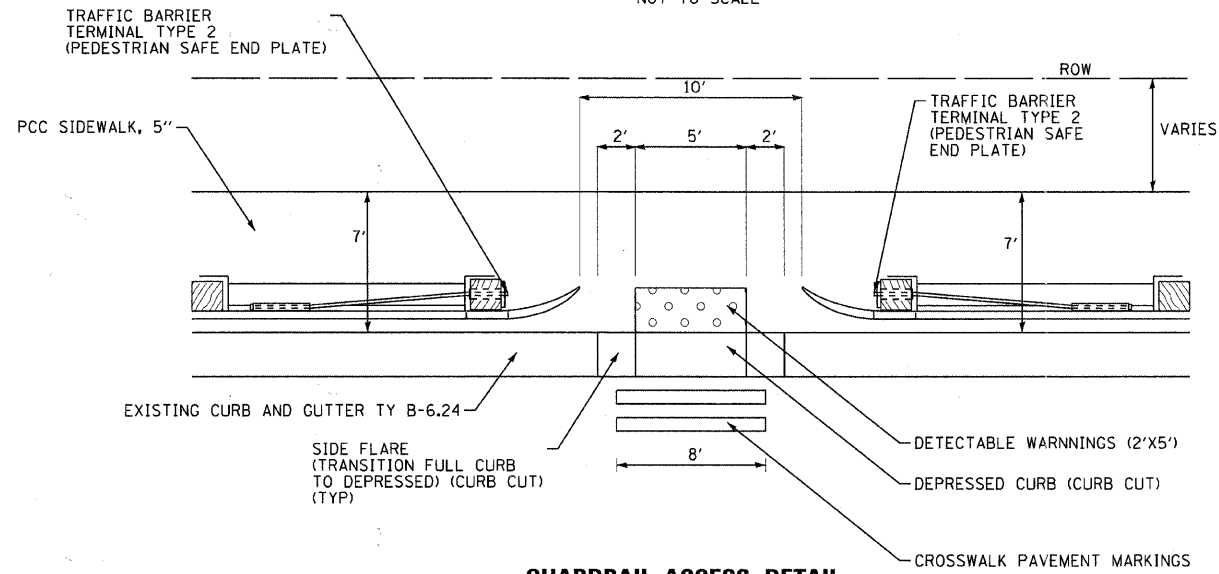

**GUARDRAIL ACCESS DETAIL**

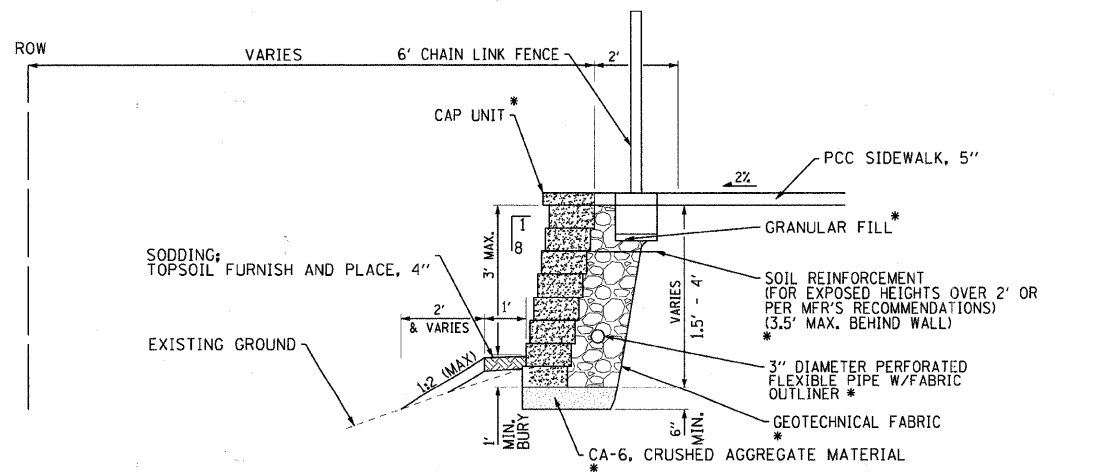

**MODULAR BLOCK RETAINING WALL DETAIL**

NO SCALE

\* (INCLUDED IN COST OF MODULAR BLOCK RETAINING WALL)

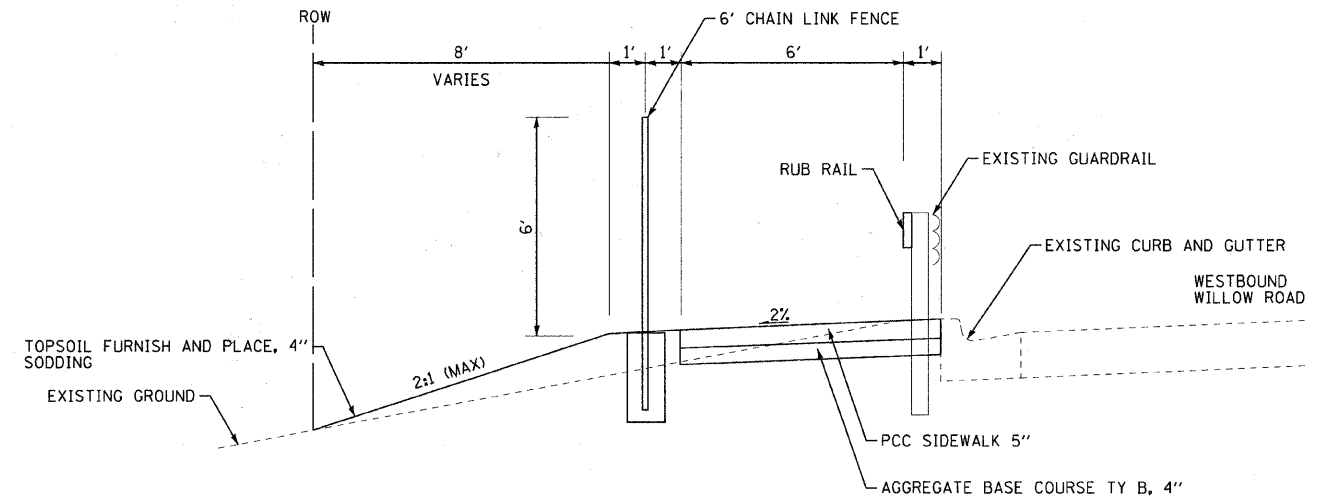

**PROPOSED TYPICAL SECTION**

STA 449+81 TO STA 451+71  
 STA 454+65 TO STA 455+68  
 STA 457+42 TO STA 457+63  
 NOT TO SCALE

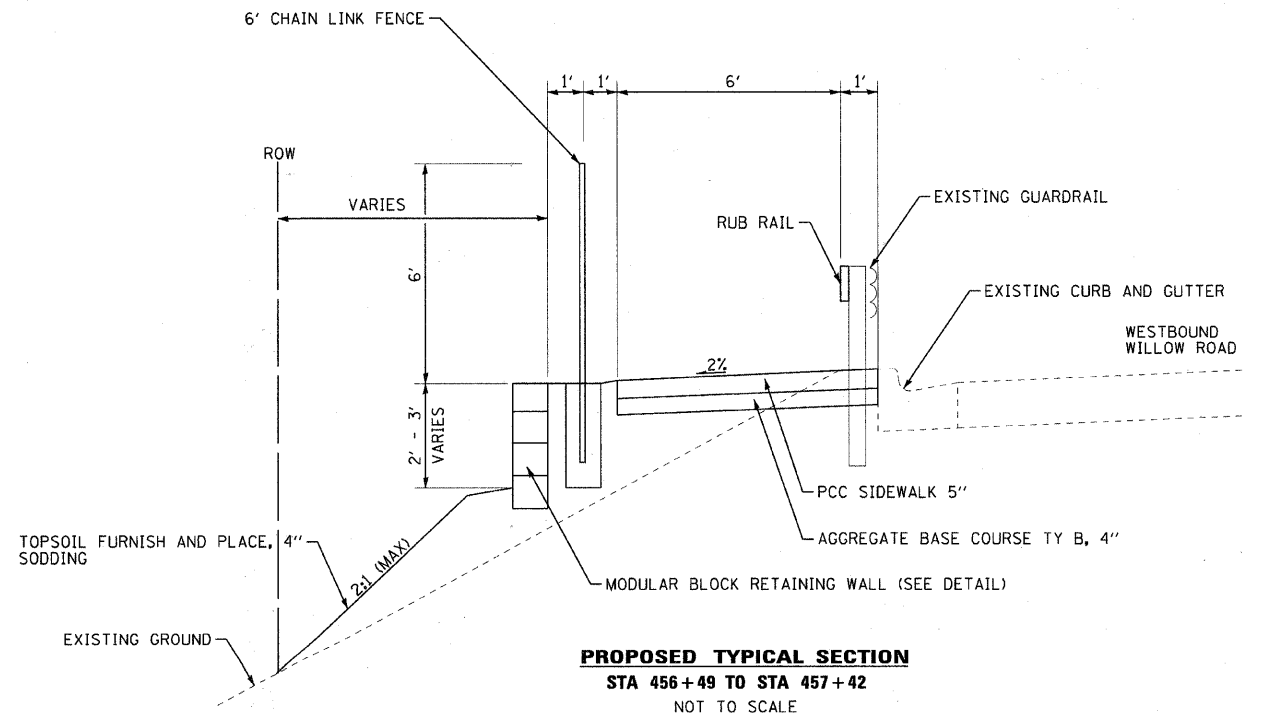

**PROPOSED TYPICAL SECTION**

STA 456+49 TO STA 457+42  
 NOT TO SCALE

COPYRIGHT © 2011 BY BAXTER & WOODMAN, INC. ALL RIGHTS RESERVED. PROJECT NO. 11-00177-00-SW. DRAWING NO. 110025-TYP-SEC.B11. DATE: 11/13/2011. 5:22:00 PM. 11/13/2011. 5:22:00 PM.



DESIGNED	- CSK	REVISED	- PER IDOT COMMENTS 6-20-11
DRAWN	- RKM	REVISED	- PER ISTHA COMMENTS 6-20-11
CHECKED	- TLH	REVISED	- PER IDOT & ISTHA COMMENTS 8-30-11
DATE	- 3-1-2011	FILE	- 110025-TYP-SEC.b11

**VILLAGE OF GLENVIEW, ILLINOIS**  
**F.A.P. 305 (WILLOW ROAD) SIDEWALK IMPROVEMENTS**

**TYPICAL SECTIONS AND DETAILS**

SCALE: NONE

STA. TO STA.

F.A.P. RTE.	SECTION	COUNTY	TOTAL SHEETS	SHEET NO.
305	11-00177-00-SW	COOK	21	5
JOB No. C-91-448-11		CONTRACT NO. 63606		
FED. ROAD DIST. NO. 1   ILLINOIS FED. AID PROJECT TE-0001859				