

PLAN
END BRACKET ASSEMBLY - LEFT

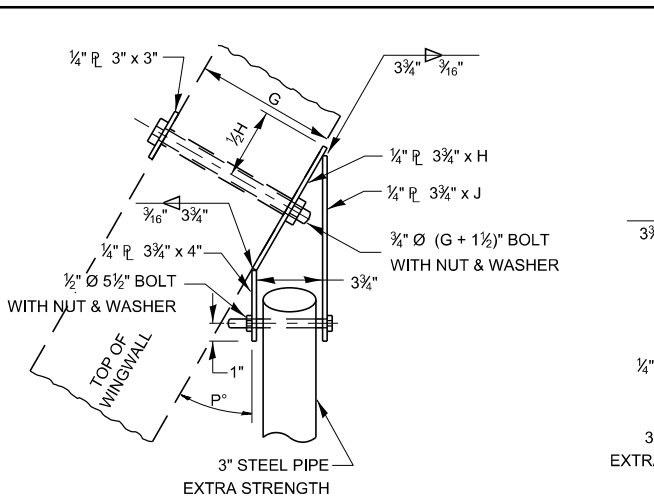

PLAN
WINGWALL BRACKET ASSEMBLY - LEFT

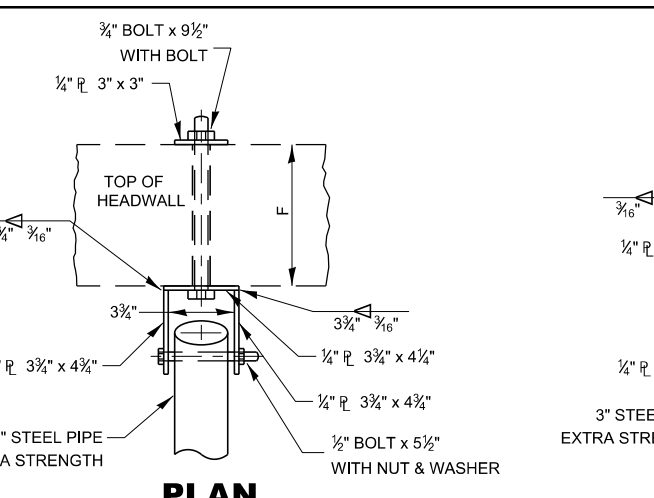

PLAN
HEADWALL BRACKET ASSEMBLY

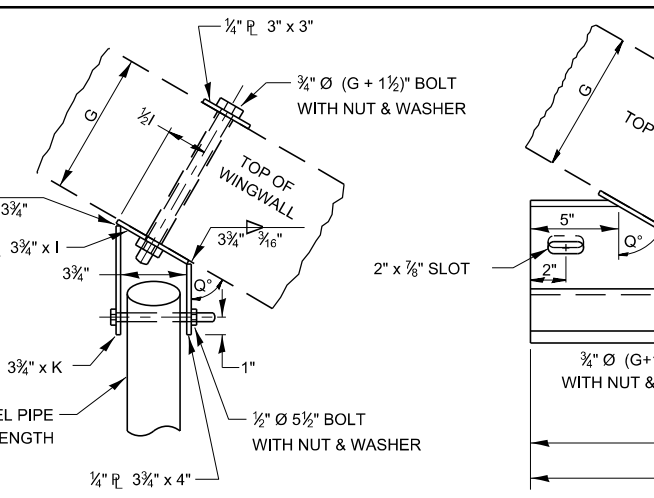

PLAN
WINGWALL BRACKET ASSEMBLY - RIGHT

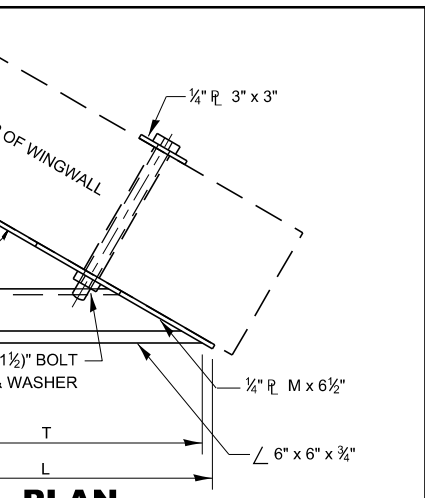

PLAN
END BRACKET ASSEMBLY - RIGHT

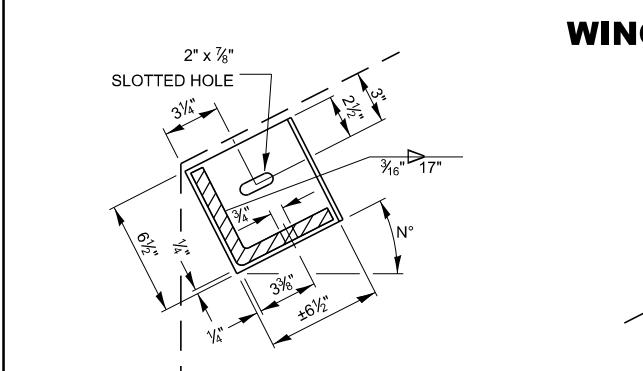

SECTION THRU
DETAIL A

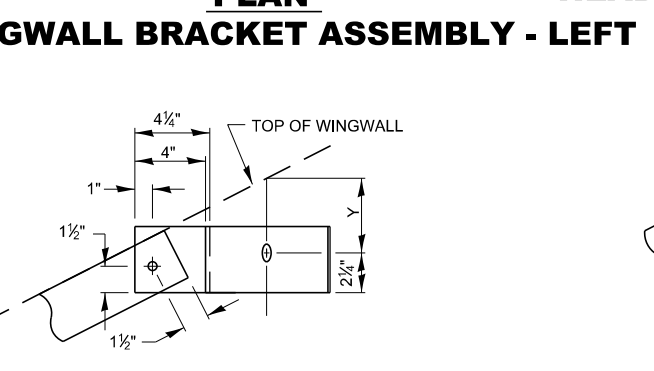

SECTION THRU
DETAIL B

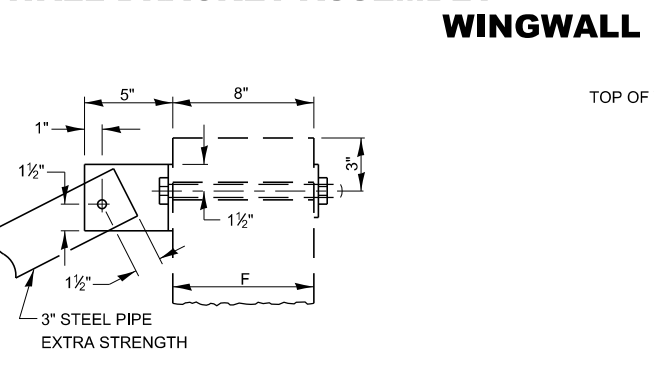

SECTION THRU
DETAIL C

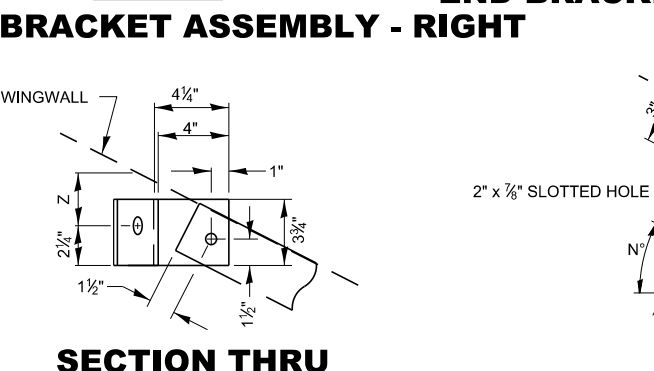

SECTION THRU
DETAIL D

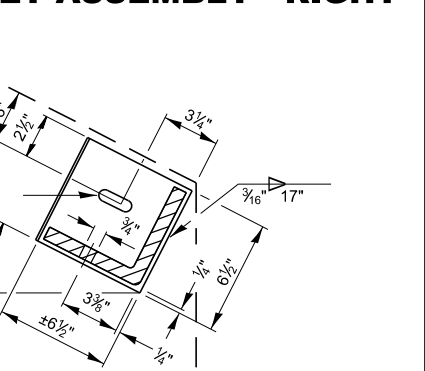

SECTION THRU
DETAIL E

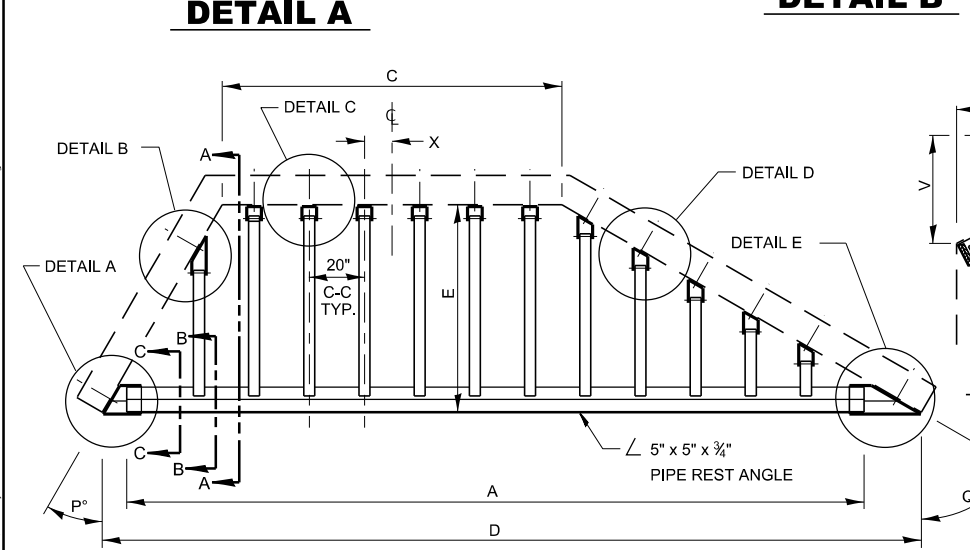

PLAN VIEW

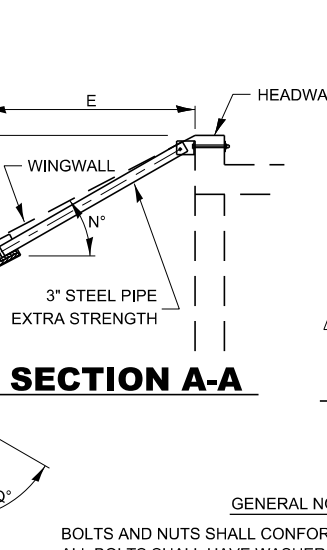

SECTION A-A

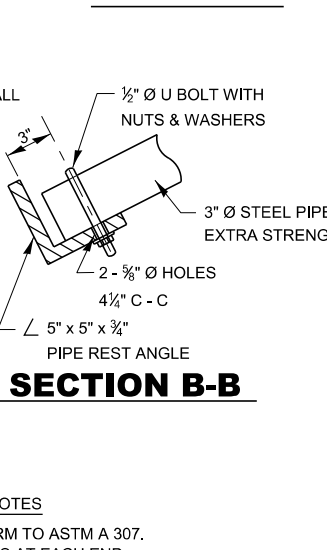

SECTION B-B

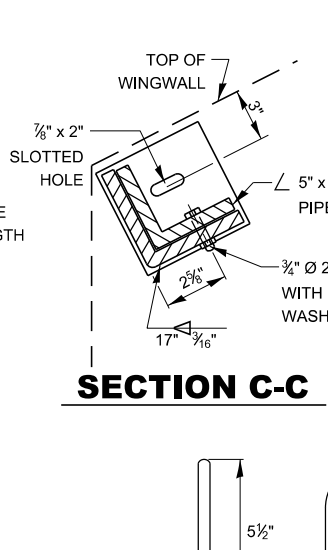

SECTION C-C

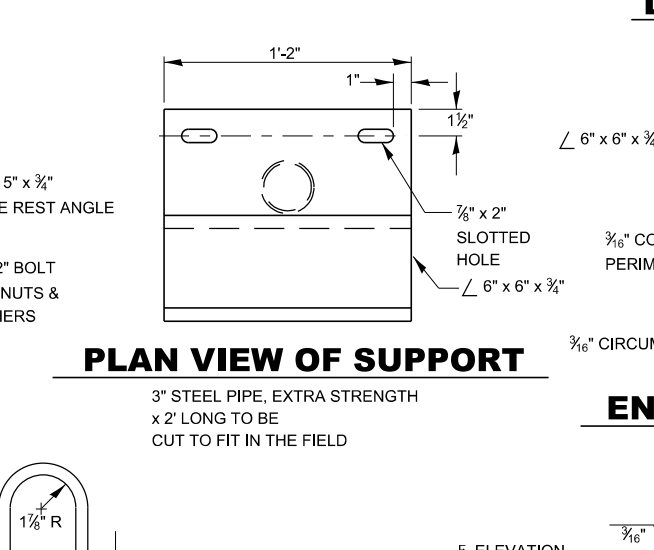

PLAN VIEW OF SUPPORT

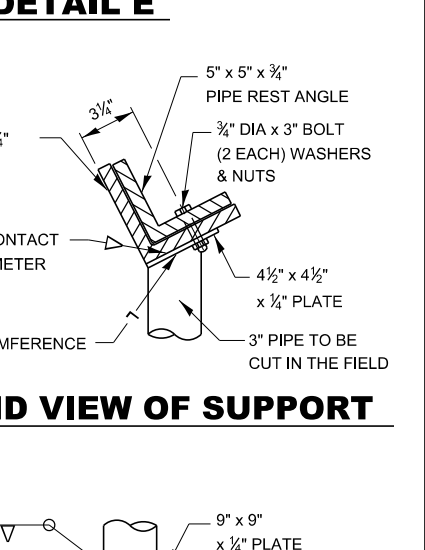

END VIEW OF SUPPORT

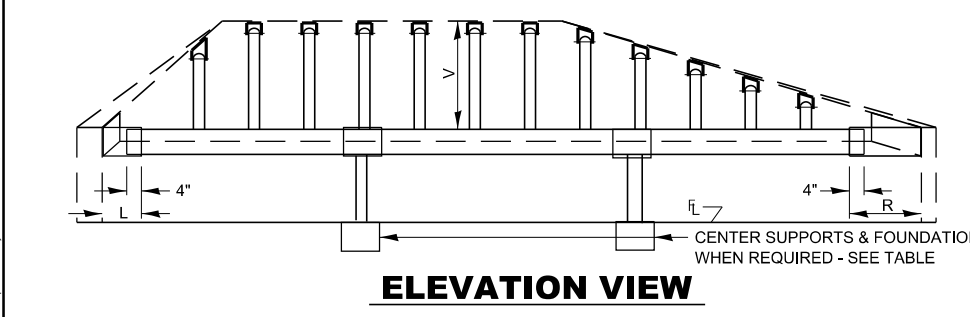

ELEVATION VIEW

GENERAL NOTES
 BOLTS AND NUTS SHALL CONFORM TO ASTM A 307. ALL BOLTS SHALL HAVE WASHERS AT EACH END. HOLES SHALL BE 1/16\"/>

ANGLES AND STEEL PLATES SHALL CONFORM TO AASHTO M183. STEEL PIPES SHALL CONFORM TO ASTM A53 GRADE B OR ASTM A 501. STEEL PIPES, ANGLES AND PLATES SHALL BE HOT DIPPED GALVANIZED CONFORMING TO THE REQUIREMENTS OF AASHTO M111. BOLTS, NUTS AND WASHERS SHALL BE HOT DIPPED GALVANIZED CONFORMING TO THE REQUIREMENTS OF AASHTO M232. THE APPROXIMATE WEIGHT OF STEEL GIVEN IN TABLES INCLUDES PLATES, ANGLES, AND PIPES. BOLTS, NUTS AND WASHERS ARE NOT INCLUDED. ALL DIMENSIONS ARE TO BE VERIFIED IN THE FIELD. CUTTING OF THE EXTRA STRENGTH PIPE AND ANGLES TO THE EXACT LENGTHS AND DRILLING HOLES IS TO BE DONE IN THE FIELD. THIS WORK SHALL BE PAID FOR AT THE CONTRACT UNIT PRICE "EACH" FOR GRATING FOR CONCRETE HEADWALLS IN PLACE, AND SHALL INCLUDE FABRICATION PAINTING, CENTER SUPPORTS WHEN REQUIRED, AND INSTALLATION OF THE GRATING AS DETAILED.

TIP TO TIP OF WINGWALLS (DIMENSION "D")	NUMBER OF SUPPORTS REQUIRED	LOCATION
0'-0" TO 12'-6"	0	—
12'-6" TO 18'-0"	1	CENTER OF SPAN
18'-0" TO 24'-0"	2	1/3 OF SPAN
24'-0" TO 30'-0"	3	1/4 OF SPAN

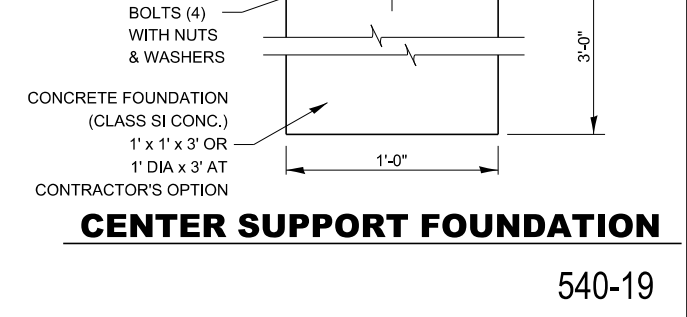

CENTER SUPPORT FOUNDATION

USER NAME = Anthony.Grunstad	DESIGNED -	REVISED -
DESIGNED -	DRAWN -	REVISED -
DRAWN -	CHECKED -	REVISED -
CHECKED -	DATE -	REVISED -
DATE - 9/27/23		

STATE OF ILLINOIS
DEPARTMENT OF TRANSPORTATION

GRATING FOR CULVERTS WITH WINGWALLS

F.A. RTE.	SECTION	COUNTY	TOTAL SHEETS	SHEET NO.
CONTRACT NO.				
ILLINOIS FED. AID PROJECT				